

# **UNION SPECIAL**

**Industrial Sewing Machines**

**THE FIFTY THOUSAND SERIES**

**List of Parts**

**Styles in Classes**

**51200**

**51600**

**51400**

**51700**

**Catalog No. 92L**

**UNION SPECIAL MACHINE COMPANY  
CHICAGO**

Catalog No. 92 L

LIST OF PARTS

STYLES IN CLASSES

51200	51600
51400	51700

THE FIFTY THOUSAND SERIES

The parts listed in this catalog are  
furnished at list prices for repairs only.

First Edition

Copyright 1942  
By  
Union Special Machine Co.  
Rights Reserved In All Countries  
Union Special Machine Company  
Chicago U.S.A.

Printed in U.S.A.

## OFFICES, SERVICE STATIONS, FOREIGN DISTRIBUTORS

- ★ CHICAGO, ILL. Union Special Machine Co., 404 N. Franklin St. Main Office and Factory. T. S. Whitsel, Gen. Sales Mgr. T. M. Murphey, Manager, Distribution and Service. L. C. Morris, Foreign Sales Mgr. A. E. Brauch, Manager, Product Application Division. *Tel. Superior 6920.*
- ALLENTOWN, PA. 1033 N. 22nd St. B. C. Mathews. *Tel. 2-1330.*
- ★ ATLANTA, GA. Spring at Biltmore Pl. P. T. McLendon, Mgr. *Tel. Atwood 2733 and 2734.*
- BALTIMORE, MD. 34 S. Eutaw St. C. D. Mairs. *Tel. Saratoga 8499.*
- ★ BOSTON, MASS. 210 South St. Wm. E. Palm, Mgr. *Tel. Liberty 0147-48.*
- ★ CINCINNATI, O. 422 Temple Bar Bldg. W. E. LeRoy, Mgr. *Tel. Parkway 2521.*
- CLEVELAND, O. 1276 W. Third St. H. B. Dyer. *Tel. Main 9657.*
- COLUMBUS, OHIO. 1669 Elmwood Ave. R. J. Lindhorst. *Tel. Kingswood 5520.*
- DALLAS, TEXAS. 2719 N. Haskell St. J. H. Muir. *Tel. 8-1084.*
- DETROIT, MICH. 11832 Ohio Ave. John Lux. *Tel. Hogarth 5289.*
- FALL RIVER, MASS. 186 Garden St. E. J. Bernier. *Tel. 2-5120.*
- FT. WORTH, TEX. 912 Morningside Drive. H. M. Petershagen. *Tel. 4-7776.*
- GREENSBORO, N. C. 4109 Walker Ave. L. F. McGwier. *Tel. 6301.*
- GREENVILLE, S. C. 601 Cleveland St. O. S. Bachelor. *Tel. 5404W.*
- INDIANAPOLIS, IND. 3731 N. Tacoma Ave. B. L. Rogers. *Tel. Cherry 2521.*
- JACKSON, MISS. 909 Whitworth St. M. O. Moulton. *Tel. 2-2924.*
- JOHNSON CITY, N. Y. 49 Cherry St. Wm. Browne. *Tel. 7-3179.*
- KANSAS CITY, MO. 3616 E. 59th St. T. O. Biggers. *Tel. Highland 5797.*
- LOS ANGELES, CAL. 119 E. Pico Blvd. C. E. Downs. *Tel. Prospect 5636.*
- MINNEAPOLIS, MINN. 3608 27th Ave. So. R. W. Bredahl. *Tel. Drexel 3331.*
- MONTREAL, QUE. Blvd. St. Laurent at Prince Arthur. S. J. Storey. *Tel. LA 7944.*
- NASHVILLE, TENN. Observatory Drive. W. J. Brauch. *Tel. 8-5123.*
- NEWARK, N. J. 60 Park Place. H. K. Lanning. *Tel. Market 3-3123.*
- NEW HAVEN, CONN. 500 Eastern St. C. H. Verdeur.
- NEW ORLEANS, LA. 3823½ Cleveland Ave. J. A. Boyette. *Tel. Audubon 6045.*
- ★ NEW YORK, N. Y. 116 E. 27th St. Wm. Bleicher, Mgr. *Tel. Murray Hill 4-4665 or 4-4666.*
- ★ PHILADELPHIA, PA. 1316 Arch St. Ben W. Merz, Mgr. *Tel. (Bell) Locust 1023 & 1024, (Key.) Race 1078.*
- PITTSBURGH, PA. 1134 Illinois Ave. Elton S. Rockney. *Tel. Locust 1086.*
- PORTLAND, ORE. 3936 S. E. Main St. I. C. Looper. *Tel. EA 9003.*
- POTTSVILLE, PA. 20 South Center St. L. J. Perrin. *Tel. 2508.*
- ★ ST. LOUIS, MO. 1700 Olive St. E. E. Gratsch, Mgr. *Tel. Chestnut 2368.*
- ★ SAN FRANCISCO, CAL. 371 4th St. J. W. McLain, Mgr. *Tel. Garfield 7999.*
- ★ TORONTO, ONT. 137 Wellington St. G. A. Rundle, Mgr. *Tel. Adelaide 2909.*
- UTICA, N. Y. 33 Leslie St. P. J. Steeper. *Tel. 4-6422.*
- WATERFORD, N. Y. 22 Fourth St. A. J. Brown. *Tel. 467.*
- WINNIPEG, MAN. 1065 Dominion St. Walter Baldwin. *Tel. 24244.*
- WORCESTER, MASS. 1 Einhorn Rd. F. E. Hodtun. *Tel. 2-1412.*
- YORK, PA. 837 Florida Ave. Wm. Denholm. *Tel. 64196.*

### OVERSEAS

- AFRICA—Capetown, Durban, Johannesburg, Port Elizabeth, South Africa. Port Louis, Mauritius, Cairo, Egypt.
- ASIA—Calcutta, India.
- ASIA MINOR—Tel Aviv, Palestine, Beirut, Syria, Baghdad, Iraq, Teheran, Iran.
- AUSTRALIA—Brisbane, Melbourne, Perth, Sydney.
- EUROPE—Leicester, London and Manchester, England. Oporto, Portugal. Dundee and Glasgow, Scotland. Barcelona, Spain. Boras, Stockholm and Orebro, Sweden. Zurich, Switzerland.
- NEW ZEALAND—Auckland, Christchurch, Dunedin, Wellington.
- NORTH AMERICA—Havana, Cuba. Mexico City and Monterrey, Mexico. Jamaica, B. W. I. San Juan, P. R.
- PACIFIC ISLANDS—Honolulu, Hawaii.
- SOUTH AMERICA—Buenos Aires, Argentina. Porto Alegre, Sao Paulo, Recife, Brazil. Santiago, Chile. Barranquilla, Bogota, Medellin, Colombia. Guayaquil, Ecuador. Lima, Peru. Montevideo, Uruguay. Caracas, Venezuela.

\*MAIN OFFICES

## FOREWORD

The dominating idea back of "Union Special" is to build the best industrial sewing machines in the world. Our new line of high speed flat bed machines in Classes 51200, 51400, 51600 and 51700, is a pronounced achievement along these lines. All parts are made to gauges with exceedingly close limits.

It is our constant aim to furnish carefully prepared information that will enable the customer to secure all possible economies and advantages from the use of Union Specials. On the pages which follow will be found illustrations and descriptions of the parts for styles in Classes 51200, 51400, 51600 and 51700.

Additional catalogs, containing information relative to these machines, and which will be furnished on request, are listed below:

Catalog No. 29	
Third Edition	List of miscellaneous accessories and transmitter parts.
Catalog No. 45	Needle Manual.
Catalog No. 45 A	Price List of Needles.
Form 357	Engineering Department Adjusting Instructions. Specify the style of machine for which the adjusting instructions are required.

In all manufacturing centers will be found Union Special representatives, who will cooperate with those who desire in planning and estimating their requirements.

UNION SPECIAL MACHINE COMPANY

Engineering Department

## IDENTIFICATION OF MACHINES

Each Union Special carries a style number which is stamped on the name plate on the machine. Style numbers are classified as standard and special. Those which are standard have one or more letters suffixed but never contain the letter "Z". Example; 51400 P. Style numbers containing the letter "Z" are special. When minor changes are made from a standard machine style, a "Z" is suffixed to the standard style number. Example: 51400 PZ.

Styles of machines similar in construction are grouped under a class number which differs from the style numbers in that it contains no letters. Example: 51400.

Certain special machines, not readily identifiable with a particular machine style, have the letter "Z" suffixed to the class number alone. Example: 51400 Z.

The distance between the rows of stitches in Class 51400, 51600 and 51700 machines is represented by a gauge number measured in 1/64ths of an inch, viz: 12 gauge represents a distance of 12/64 or 3/16 inch. 64 gauge represents a distance of 64/64 or 1 inch.

## APPLICATION OF CATALOG

This catalog applies only to the standard styles of machines herein listed. It can be applied with discretion to the special machines covered by these classes.

### STYLES OF MACHINES IN CLASS 51200

Enclosed Type Flat Bed One Needle Light Duty Machines  
Double Locked Stitch Type 401, Lateral Looper Travel.

51200 A (succeeds 6400 I, 15900 D). For binding aprons, dresses and similar garments; seam Type BSc-1, capillary oiling system. Type 106 needle, uses cut edge strips, standard widths 3/4, 7/8, 1 1/8, and 1 1/4 inch.

51200 B (succeeds 6400 M). For seaming mattress ticks; bound seam Type BSa-1, English binder, capillary oiling system, Type 126 needle, uses selvage edge strip, standard widths 5/8, 3/4 and 7/8 inch.

51200 C (succeeds 6400 W). For seaming mattress ticks; plain seam, capillary oiling system, Type 126 needle.

51200 D (succeeds 1700 F, 1700 H). For seaming canton flannel and jersey cloth gloves, also leather palm gloves; seam Type SSa-1, capillary oiling system, Type 101 needle.

51200 G (succeeds 6400 N). For joining shoulders of shirts; one operation, seam Type LSe-1, capillary oiling, Type 106 needle.

STYLES OF MACHINES IN CLASS 51200 (Cont'd)

- 51200 H (succeeds 6000 A). For miscellaneous operations on knitted drawer bands and knitted shirt fronts; capillary oiling system, Type 101 needle.
- 51200 J (succeeds 15900 F). For attaching one piece extension button stays to front and sleeves of woven shirts, also facing sleeves; seam Type BSc-1, capillary oiling, Type 106 needle, strips used in either garment length or long lengths, standard widths  $1/2$ ,  $3/4$ ,  $7/8$  and 1 inch.
- 51200 K (succeeds 6400 I, 15900 D, 51200 A). For binding aprons, dresses, and similar garments; seam Type BSc-1, enclosed type oiling system for looper drive eccentric and crank, Type 106 needle, uses cut edge strip, standard widths  $3/4$ ,  $7/8$ , 1  $1/8$ , and 1  $1/4$  inch.
- 51200 L (succeeds 6400 M, 51200 B). For seaming mattress ticks; bound seam Type BSa-1, English binder, enclosed type oiling system for looper drive eccentric and crank, Type 126 needle, uses selvage edge strip, standard widths  $5/8$ ,  $3/4$  and  $7/8$  inch.
- 51200 M (succeeds 6400 W, 51200 C). For seaming mattress ticks; plain seam, enclosed type oiling system for looper drive eccentric and crank, Type 126 needle.
- 51200 N (succeeds 1700 F, 1700 H, 51200 D). For seaming canton flannel and jersey cloth gloves, also leather palm gloves; seam Type SSa-1, enclosed type oiling system for looper drive eccentric and crank, needle Type 101.
- 51200 R (succeeds 6400 N, 51200 G). For joining shoulders of shirts, one operation; seam Type LSa-1, enclosed type oiling system for looper drive eccentric and crank, Type 106 needle.
- 51200 S (succeeds 6000 A, 51200 H). For miscellaneous operations on knitted drawer bands and knitted shirt fronts; enclosed type oiling system for looper drive eccentric and crank, needle Type 101.
- 51200 T (succeeds 15900 F, 51200 J). For attaching one piece extension button stays to front and sleeves of woven shirts, also facing sleeves: seam Type BSc-1, enclosed type oiling for looper drive eccentric and crank, Type 106 needle, strips used in either garment length or long lengths, standard widths  $1/2$ ,  $3/4$ ,  $7/8$  and 1 inch.
- 51200 U For attaching one piece extension button stays to front and sleeves of woven shirts, also facing sleeves; seam Type BSc-1, upper roller feed, capillary oiling system, Type 106 needle, strips used in either garment lengths or long lengths, standard widths  $1/2$ ,  $5/8$ ,  $3/4$ ,  $7/8$  and 1 inch.

STYLES OF MACHINES IN CLASS 51200 (Cont'd)

- 51200 V For attaching one piece extension button stays to knitted undergarments; seam Type BSc-1, upper roller feed, thumbscrew adjustment off-set differential feed, capillary oiling system, needle Type 106, strips used in long lengths, standard widths  $\frac{3}{8}$ ,  $\frac{1}{2}$ ,  $\frac{9}{16}$ ,  $\frac{5}{8}$ ,  $\frac{3}{4}$ ,  $\frac{7}{8}$ , and 1 inch.
- 51200 Z A special style, similar to the standard styles in Class 51200, but differing in one or more of its component parts.

STYLES OF MACHINES IN CLASS 51400

- Enclosed Type Flat Bed Independent Row Two Needle Light Duty Machines, Left Needle in Front, Double Locked Stitch Type 401, Lateral Looper Travel.
- 51400 A (succeeds 7400 A, 7400 B). For piecing sleeves, joining shoulders and setting sleeves of ordinary quality shirts and similar garments made of medium and light weight materials; double stitch felled seam Type LSc-2,  $\frac{5}{32}$  inch space between needles in line with feed, feed surface between needles of No. 16 and wider gauges, capillary oiling system, Type 106 needles, standard gauges Nos. 6, 8, 10, 12, 16 and 18.
- 51400 B (succeeds 7400 X). For folding and attaching extension center plait, interlining strip and facing strip to front of shirts and similar garments; one operation, seam Type LSj-2, plaits used in garment lengths and extend  $\frac{1}{4}$  inch beyond the rows of stitches, facing and interlining strips used in long lengths, starts operation at neck,  $\frac{5}{32}$  inch space between needles in line with feed, "Tru-Front" folder, capillary oiling system, Type 106 needles, standard gauge No. 48.
- 51400 C (succeeds 7400 AH). Same as 51400 B, except it is designed for folding and attaching set-on center plait and interlining strip; seam Type LSm-2.
- 51400 D (succeeds 7400 AL). For folding and attaching inside button facing to shirts and similar garments; one operation, seam Type LSk-2,  $\frac{1}{16}$  inch margins, facing strip used in long lengths and guided next to feed dog, starts operation at neck,  $\frac{5}{32}$  inch space between needles in line with feed. Capillary oiling system Type 106 needles, standard gauges Nos. 32 and 48.

STYLES OF MACHINES IN CLASS 51400 (Cont'd)

- 51400 E For piecing sleeves, joining shoulders, and setting sleeves of extra fine quality shirts and similar garments made of medium and light weight materials; double stitch felled seam Type LSc-2, 5/32 inch space between needles in line with feed, feed surface between needles for all gauges capillary oiling system, Type 106 needles, standard gauges Nos. 8, 10, 12, 16
- 51400 F For "cut-on" button stay operation on shirts; turn down hem seam Type Efb-2 inverted, starts operation at neck, 5/32 inch space between needles in line with feed, capillary oiling system Type 106 needles, standard width of hem 5/8 inch; standard gauge No. 32.
- 51400 G (succeeds 7400 AG). For hemming bloomers and similar garments made from knitted fabrics, and simultaneously inserting an elastic band within the hem, seam Type Efg-2, 3/16 inch space between needles in line with feed, 1 1/8 inch, parallel take-up, built in puller, capillary oiling system Type 101 needles, standard gauges Nos. 16, 18 and 24, standard widths of heading 1/8, 3/16 and 1/4 inch for Nos. 16 and 18 gauge machines, standard width of heading 1/8 inch for No. 24 gauge machines.
- Note: By using a knee press No. 21691 A, the operator can shift the elastic into the left row of stitches at the start and finish of the hem.
- 51400 H (succeeds 7000 A). For uniting the lower edge of French drawer bands to the body fabric; 3/16 inch space between needles in line with feed, capillary oiling system, Type 101 needles, standard gauges Nos. 16 and 18.
- 51400 J (succeeds 7400 B). For setting sleeves of extra fine quality shirts and similar garments made from medium and light weight materials; double stitch felled seam Type LSc-2, 3/16 inch space between needles in line with feed, feed surface between needles, capillary oiling system, Type 106 needles, standard gauge No. 26.
- 51400 K For quilting collar bands of shirts and similar garments, 5/32 inch space between needles in line with feed, capillary oiling system, Type 106 needles, standard gauges Nos. 24 and 26.
- 51400 M (succeeds 7400 AK). For folding and attaching single piece facings to sleeves of shirts and similar garments, one operation, facing used in garment lengths, capillary oiling system, Type 106 needles, standard gauge No. 48.



STYLES OF MACHINES IN CLASS 51400 (Cont'd)

- 51400 N For "cut-on" button stay operation on shirts, turn up hem, starts operation at neck,  $5/32$  inch space between needles in line with feed, capillary oiling system, Type 106 needles, standard width of hem  $7/8$  inch, standard gauge No. 48.
- 51400 P (succeeds 7400 A, 7400 B, 51400 A). For piecing sleeves, joining shoulders and setting sleeves of ordinary quality shirts and similar garments made of medium and light weight materials; double stitch felled seam Type LSc-2,  $5/32$  inch space between needles in line with feed, feed surface between needles of No. 16 and wider gauges, enclosed type oiling system for looper drive eccentric and crank, Type 106 needles, standard gauges Nos. 6, 8, 10, 12, 16 and 18.
- 51400 Q (succeeds 7400 X, 51400 B). For folding and attaching extension center plait, interlining strip and facing strip to fronts of shirts and similar garments; one operation, seam Type LSj-2, plaits used in garment lengths and extend  $1/4$  inch beyond the rows of stitches, facing and interlining strips used in long lengths, starts operation at neck,  $5/32$  inch space between needles in line with feed, enclosed type oiling system for looper drive eccentric and crank, Type 106 needles, standard gauge No. 48.
- 51400 R (succeeds 7400 AH, 51400 C). Same as 51400 Q, except it is designed for folding and attaching set-on center plait and interlining strip, seam Type LSM-2.
- 51400 S (succeeds 7400 AL, 51400 D). For folding and attaching inside button facing to shirts and similar garments; one operation, seam Type LSk-2, with  $1/16$  inch margins, facing strip used in long lengths and guided next to feed dog, starts operation at neck,  $5/32$  inch space between needles in line with feed, enclosed type oiling system for looper drive eccentric and crank, Type 106 needles, standard gauges Nos. 32 and 48.
- 51400 T (succeeds 51400 E). For piecing sleeves, joining shoulders and setting sleeves of extra fine quality shirts and similar garments made of medium and light weight materials; double stitch felled seam Type LSc-2,  $5/32$  inch space between needles in line with feed, feed surface between needle for all gauges, enclosed type oiling system for looper drive eccentric and crank, Type 106 needles, standard gauges Nos. 8, 10, 12 and 16.

STYLES OF MACHINES IN CLASS 51400 (Cont'd)

- 51400 U (succeeds 51400 F). For "cut-on" button stay operation on shirts; turn down hem, stitching Type Efb-2 inverted; starts operation at neck, 5/32 inch space between needles in line with feed, enclosed type oiling system for looper drive eccentric and crank, Type 106 needles, standard width of hem 5/8 inch, standard gauge No. 32.
- 51400 V (succeeds 7000 A, 51400 H). For uniting the lower edge of French drawer bands to the body fabric; seam Type LSd-2, 3/16 inch space between needles in line with feed, enclosed type oiling system for looper drive eccentric and crank, Type 101 needles, standard gauges Nos. 16 and 18.
- 51400 W (succeeds 7400 B, 51400 J). For setting sleeves of extra fine quality shirts and similar garments made from medium and light weight materials; double stitch felled seam Type LSc-2, 3/16 inch space between needles in line with feed, feed surface between needles, enclosed type oiling system for looper drive eccentric and crank, Type 106 needles, standard gauge No. 26.
- 51400 X (succeeds 51400 K). For quilting collar bands of shirts and similar garments; 5/32 inch space between needles in line with feed, enclosed type oiling system for looper drive eccentric crank, Type 106 needles, standard gauges Nos. 24 and 26.
- 51400 Y (succeeds 51400 L). For folding and attaching set-on button stay to fronts of work shirts and similar garments; seam Type Lsk-2, 1/32 inch margins, stays used in garment lengths and guided next to presser foot, starts operation at neck, 5/32 inch space between needles in line with feed, folder presser foot, enclosed type oiling system for looper drive eccentric and crank, Type 106 needles, standard Gauge No. 32.
- 51400 Z A special style similar to the standard styles in Class 51400, but differing in one or more of its component parts.
- 51400 AA (succeeds 7400 AK, 51400 M). For folding and attaching single piece facing to sleeves of shirts and similar garments; one operation, seam Type BSc-2, facing used in garment lengths, 5/32 inch space between needles in line with feed, enclosed type oiling system for looper drive eccentric and crank, Type 106 needles, standard gauge No. 48.

## STYLES OF MACHINES IN CLASS 51400 (Cont'd)

51400 AB (succeeds 51400 N). For "cut-on" button stay operation on shirts; turn up hem, stitching Type EFb-2, starts operation at neck, 5/32 inch space between needles in line with feed, enclosed type oiling system for looper drive eccentric and crank, Type 106 needles, standard width of hem 7/8 inch, standard gauge No. 48.

51400 AC For setting puff sleeves in waists, pajamas and similar garments made from light weight woven fabrics and similar operations where a large percent of the work calls for intermittently or continuously gathered curved seams and a small percent calls for intermittently or continuously gathered straight seams, seam Type LSc-2, upper ply of fabric passes to right of needles 5/32 inch space between needles in line with feed, treadle controlled 3 to 1 differential feed gathering mechanism, capillary oiling system, Type 106 needles, standard gauges Nos. 12 and 16.

## STYLES OF MACHINES IN CLASS 51600

Enclosed Type Flat Bed Independent Row Two Needle Machines Right Needle in Front, 1/8 inch space between needles in line with feed, Double Locked Stitch Type 401, Lateral Looper Travel.

51600 A For gathering and attaching ruffles to body of garments made from light weight woven fabrics and similar operations where a large percent of the work calls for an intermittently or continuously gathered straight seam and a small percent of the work calls for an intermittently or continuously gathered curved seam; Type LSc-2, upper ply of fabric passes to left of needles, treadle controlled 3 to 1 differential feed gathering mechanism, capillary oiling system, Type 106 needles, standard gauges Nos. 8, 10, 12 and 16.

51600 Z A special style similar to the standard style in Class 51600, but differing in one or more of its component parts.

## STYLES OF MACHINES IN CLASS 51700

Enclosed Type Flat Bed Independent Row Two Needle Machines, Needles Abreast, Double Locked Stitch Type 401, Lateral Looper Travel

51700 C (succeeds 16200 N, 16200 Q). For folding and attaching set-on center plait and interlining strip to fronts of shirts and similar garments; one operation, seam Type LSm-2, plaits used in garment lengths and extend 1/4 inch beyond the rows of stitches, starts operation at neck, "Tru-Front" folder, capillary oiling system, Type 106 needles, standard gauges Nos. 56 and 64.

STYLES OF MACHINES IN CLASS 51700 (Cont'd)

- 51700 D (succeeds 16200 D, 16200 P). Same as 51700 C, except for folding and attaching extension center plait, interlining strip and facing strip, seam Type LSj-2, standard gauge No. 64.
- 51700 E For folding and attaching buttonhole facings to knitted undergarments; one operation, self-finish front, seam Type LSk-2, cut edge facing strip used in long lengths and guided next to feed dog, strip controlled differential top feed, capillary oiling system, Type 121 needles, standard gauges Nos. 64, 72 and 80.
- 51700 F For attaching garment length single piece extension bands to overalls and similar garments; heavy duty work, one operation, seam Type BSc-2, collapsible horn type folder, 1/16 inch seam margins, capillary oiling system, Type 128 F needles, standard gauge No. 88, includes puller.
- 51700 G For folding and attaching cuffs to pajamas and similar garments made from silk and broadcloth, and inserting a corded piping on left side of cuff, one operation, piping made from a 5/8 inch bias strip folded around a 3/32 inch cord, capillary oiling system, Type 106 needles, standard width of strip 2 1/8 inches, standard gauge No. 128, includes puller.
- 51700 H Same as 51700 G, except for flannelette fabrics; puller omitted.
- 51700 J (succeeds 16200 N, 16200 Q, 51700 C). For folding and attaching set-on center plait and interlining strip to fronts of shirts and similar garments, one operation, seam Type LSM-2, plaits used in garment lengths and extend 1/4 inch beyond the rows of stitches, starts operation at neck, "Tru-Front" folder, enclosed type oiling system for looper drive eccentric and crank, Type 106 needles, standard gauges Nos. 56 and 64.
- 51700 K (succeeds 16200 D, 16200 P, 51700 D) same as 51700 J, except for folding and attaching extension center plait, interlining strip and facing strip, seam Type LSj-2, standard gauge No. 64.
- 51700 L (succeeds 51700 E). For folding and attaching buttonhole facings to knitted undergarments; one operation, self-finish front, seam Type LSk-2, cut edge facing strip used in long lengths and guided next to feed dog, strip controlled differential top feed, enclosed type oiling for looper drive eccentric and crank, Type 121 needles, standard gauges Nos. 64, 72, and 80.

STYLES OF MACHINES IN CLASS 51700 (Cont'd)

- 51700 M (Succeeds 51700 F). For attaching garment length single piece extension bands to overalls and similar garments; heavy duty work, one operation, seam Type BSc-2, collapsible horn type folder, Type 128 F needles, standard gauges Nos. 80 and 88, includes PULLER.
- 51700 N (succeeds 51700 G). For folding and attaching cuffs to pajamas and similar garments made from silk and broadcloth, and inserting a corded piping on left side of cuff; one operation, piping made from a 5/8 inch bias strip folded around a 3/32 inch cord. Type 106 needles. Standard width of strip 2 1/8 inches, standard gauge No. 128, includes PULLER.
- 51700 P (Succeeds 51700 H). Same as 51700 N, except for flannelette fabrics, puller is omitted.
- 51700 Q For folding and attaching set on center plait to fronts of heavy weight army shirts and similar garments; one operation, seam Type LSk-2, plaits used in garment lengths and extend 1/4 inch beyond the rows of stitches, starts operation at the neck, "Tru-Front" folder, enclosed type oiling system for looper drive eccentric and crank, Type 106 needles, standard gauge No. 64.
- 51700 R For folding and attaching inside button facings to heavy weight army shirts and similar garments; one operation, seam Type LSk-2 with 1/16 inch margins, facing strip cut from body fabric, used in long lengths and guided next to feed dog, starts operation at neck, enclosed type oiling for looper drive eccentric and crank, Type 106 needles, standard gauge No. 56.
- 51700 T For attaching waistband to trousers and similar garments; heavy duty work, seam Type LSk-2, strip guided next to feed dog, capillary oiling system, Type 128 G needle, standard gauge No. 96, includes PULLER.
- 51700 U (succeeds 51700 T) For attaching waistbands to trousers and similar garments; heavy duty work, seam Type LSk-2, strip guided next to feed dog, enclosed type oiling system for looper drive eccentric and crank, Type 128 G needles, standard gauge No. 96, includes PULLER.
- 51700 Z A special style similar to the standard styles in Class 51700, but differing in one or more of its component parts.

## NEEDLES

### TYPE NUMBER AND SIZES

Each needle has a type number and size number. The former denotes the kind of shank, point, length, groove, finish, and other details. The latter denotes the largest diameter of the blade, measured in thousandths of an inch midway between the shank and eye, and is stamped in the needle shank. Collectively the type number and size number is the complete symbol.

To have orders promptly and accurately filled, the empty package, a sample needle, or the type and size numbers should be given. See marks on packages. An intelligent order would read as follows; "1000 Needles Type 106 Size .036". The type numbers of the needles available for use in the styles of machines covered by this catalog are listed below. Set opposite each type number is the description of the needle and the sizes available.

Type No.	Description
101	Round shank, round point, extra short, double groove, nickel plated- sizes 019, 022, 025, 027 029, 032, 034, 036, 038, 040, 042, 044, 046, 049, 054.
101 G	Round shank, round point, extra short, double groove, chromium plated- sizes 032, 036, 040.
101 J	Round shank, round point, extra short, double groove, taper blade, diameter across eye is the size number, plain finish- sizes 019, 022, 027.
102	Round shank, round point, extra short, double groove, short blade, 1/8 inch less than standard, nickel plated- sizes 025, 027, 032, 036, 040, 044.
104	Round shank, round point, extra short, double groove, spotted, nickel plated- sizes 036, 040, 042, 044, 049.
104 JH	Round shank, round point, extra short, double groove, spotted, ball point, taper blade, diameter across the eye is the size number, chromium plated- sizes 029, 032.
106	Round shank, round point, extra short, double groove, ball eye, standard length blade, nickel plated- sizes 027, 029, 032, 036, 038, 040, 042, 044, 049.
106 A	Same as Type 106, except blades are 1/16 inch shorter and shanks are 1/16 inch longer- sizes 032, 036.

## NEEDLES (Cont'd)

Type No.	Description
106 G	Round Shank, round point, extra short, double groove, ball eye, chromium plated--sizes 032, 036, 040, 044.
106 H	Round shank, round point, extra short, double groove, ball eye, ball point, standard length blade, nickel plated- size 040.
108	Round shank, round point, extra short, double groove, ball eye, spotted, nickel plated- sizes 032, 036, 038, 040, 042, 044, 049, 054.
108 G	Round shank, round point, extra short, double groove, ball eye, spotted, chromium plated- sizes 040, 044, 049, 054.
108 H	Round shank, round point, extra short, double groove, ball eye, ball point, spotted, nickel plated- sizes 036, 040.
108 GH	Round shank, round point, extra short, double groove, ball eye, ball point, spotted, chromium plated- sizes 036, 040, 044.
109	Round shank, round point, extra short, double groove, ball eye, government, nickel plated- sizes 027, 032, 036, 040, 044.
109 B	Round shank, round point, extra short, double groove, government, nickel plated- sizes 027, 032, 036, 040, 044, 049.
109 G	Round shank, round point, extra short, double groove, ball eye, government, chromium plated- sizes 036, 040, 044.
109 HA	Round shank, round point, extra short, double groove, ball eye, ball point, government, short blade 1/8 inch less than standard, chromium plated- size 040.
110	Round shank, round point, extra short, double groove, ball eye, government spotted, nickel plated- sizes 036, 040, 044.
110 G	Round shank, round point, extra short, double groove, ball eye, spotted, government, chromium plated- size 040.

NEEDLES (Cont'd)

Type No.	Description
110 ZL	Round shank, round point, extra short, double groove, ball eye, ball point, government, spotted, chromium plated- size 040.
121	Round shank, round point, short, double groove, nickel plated- sizes 019, 022, 025, 027, 029, 032, 036, 038, 040, 042, 044, 049, 054.
121 G	Round shank, round point, short, double groove, chromium plated- sizes 032, 036, 040, 049.
121 H	Round shank, round point, short, double groove, ball point, nickel plated- sizes 029, 032, 036.
121 J	Round shank, round point, short, double groove, taper blade, diameter across the eye is the size number, plain finish- sizes 022, 025, 027, 032.
121 JH	Round shank, round point, short, double groove, ball point, taper blade, diameter across the eye is the size number, plain finish- size 027.
124	Round shank, round point, short, double groove, spotted, nickel plated- sizes 040, 044, 049, 060, 067, 080, 090.
124 G	Round shank, round point, short, double groove, spotted, chromium plated- size 067.
126	Round shank, round point, short, double groove, ball eye, nickel plated- sizes 027, 032, 036, 040, 042, 044, 049, 054.
126 G	Round shank, round point, short, double groove, ball eye, chromium plated- sizes 040, 044, 049.
128	Round shank, round point, short, double groove, ball eye, spotted, nickel plated, standard width of eye and grooves- sizes 032, 036, 040, 044, 049, 054, 060, 067, 080.
128 F	Round shank, round point, short, double groove, ball eye, spotted, nickel plated, under-size eye and grooves, one step reduction- sizes 044, 049, 054.
128 G	Round shank, round point, short, double groove, ball eye, spotted, chromium plated, under-size eye and grooves, one step reduction- sizes 044, 049, 054.



NEEDLES (Cont'd)

Type No.	Description
128 H	Round shank, round point, short, double groove, ball eye, spotted, short blade 1/8 inch less than standard, width of eye and grooves under-size one step reduction, ball point, nickel plated- sizes 036, 040, 044, 049.
128 GA	Round shank, round point, short, double groove, ball eye, spotted, chromium plated, standard width of eye and grooves- sizes 040, 044, 049, 054.
128 HA	Round shank, round point, short, double groove, ball eye, spotted, under-size eye and grooves 27% of needle size, ball point, nickel plated- sizes 044, 049, 054.
128 HB	Round shank, round point, short, double groove, ball eye, spotted, under-size eye and grooves 27% of needle size, ball point, chromium plated- sizes 044, 049, 054.
129	Round shank, round point, short, double groove, government, nickel plated- sizes 027, 029, 032, 036, 040, 044, 049.
129 G	Round shank, round point, short, double groove, government, chromium plated- sizes 029, 032, 036, 040.
130	Round shank, round point, short, double groove, ball eye, government, spotted, nickel plated- sizes 036, 040, 044, 049, 054, 060.
130 G	Round shank, round point, short, double groove, ball eye, government, spotted, chromium plated- sizes 044, 049, 054.
130 HA	Round shank, round point, short, double groove, ball eye, government, spotted, ball point, nickel plated- sizes 044, 049, 054.
130 HB	Round shank, round point, short, double groove, ball eye, government, spotted, ball point, chromium plated- sizes 044, 049, 054.
301	Round shank, stay point, extra short, double groove, plain finish- sizes 027, 029, 032, 034, 036, 038, 040, 042, 044, 046, 049, 052, 054, 060.
301 G	Round shank, stay point, extra short, double groove, chromium plated- sizes 032, 034, 036, 038, 040, 042, 044, 049, 054

## NEEDLES (Cont'd)

Type No.	Description
302	Round shank, stay point, extra short, double groove, nickel plated- sizes 032, 036, 040, 042, 044, 049.
501	Round shank, rocked point, extra short, double groove, plain finish- sizes 029, 032, 034, 036, 038, 040, 042, 044, 046.
501 G	Round shank, rocked point, extra short, double groove, chromium plated- sizes 036, 038, 040, 042.
907	Round shank, spear point, extra short, double groove, ball eye, nickel plated- sizes 027, 032, 034, 036, 040, 042, 044, 049, 054.
929	Round shank, spear point, short, double groove, ball eye, spotted, nickel plated- sizes 044, 049, 054, 060, 067, 080.
1501	Round shank, twist point, extra short, double groove, plain finish- sizes 027, 029, 032, 034, 036, 038, 040, 042, 044, 049, 052, 054, 060.
1701	Round shank, twist centered point, extra short, double groove, plain finish- sizes 029, 032, 034, 036, 038, 040, 042, 044, 046, 049, 054, 060.
1701 G	Round shank, twist centered point, extra short, double groove, chromium plated- size 038.

### APPLICATION OF TYPE NUMBERS TO MACHINES

The standard type of needle applicable to each style is listed in the description of each style. The styles of machines covered by this catalog are listed below. Set opposite each style number is the type numbers of the needles that can be used. Type numbers are arranged numerically, as the variety of the materials sewed on each machine makes it impractical to show a preference.

Machine Style	Type of Needles
51200 A	104 JH, 106, 106 A, 106 G, 106 H, 108, 108 G, 108 H, 108 GH, 109, 109 G, 110, 110 G, 110 ZL, 302, 907
51200 B	126, 126 G, 128, 128 F, 128 G, 128 GA, 130, 130 G, 929
51200 C	126, 126 G, 128, 128 F, 128 G, 128 GA, 130, 130 G, 929
51200 D	101, 101 G, 101 J, 102, 104, 104 JH
51200 G	104 JH, 106, 106 A, 106 G, 106 H, 108, 108 G, 108 H, 108 GH, 109, 109 B, 109 G, 109 HA, 110, 110 G, 110 ZL, 302, 907

NEEDLES (Cont'd)

APPLICATION OF TYPE NUMBERS TO MACHINES (Cont'd)

Machine Style	Type of Needles
51200 H	101, 101 G, 101 J, 104, 104 JH, 106, 106 G, 109 B
51200 J	104 JH, 106, 106 A, 106 G, 106 H, 108, 108 G, 108 H, 108 GH, 109, 109 B, 109 G, 109 HA, 110, 110 G, 110 ZL, 302, 907
51200 K	104 JH, 106, 106 A, 106 G, 106 H, 108, 108 G, 108 H, 108 GH, 109, 109 G, 110, 110 G, 110 ZL, 302, 907
51200 L	126, 126 G, 128, 128 F, 128 G, 128 GA, 130, 130 G, 929
51200 M	126, 126 G, 128, 128 F, 128 G, 128 GA, 130, 130 G, 929
51200 N	101, 101 G, 101 J, 102, 104, 104 JH
51200 P	101, 101 G, 104, 106, 106 A, 106 G, 108, 108 G, 301, 301 G, 302, 501, 501 G, 1501, 1701, 1701 G
51200 Q	101, 101 G, 104, 106, 106 A, 106 G, 108, 108 G, 301, 301 G, 302, 501, 501 G, 1501, 1701, 1701 G
51200 R	104 JH, 106, 106 A, 106 G, 106 H, 108, 108 G, 108 H, 108 GH, 109, 109 B, 109 G, 109 HA, 110, 110 G, 110 ZL, 302, 907
51200 S	101, 101 G, 101 J, 104, 104 JH, 106, 106 G, 109 B
51200 T	104 JH, 106, 106 A, 106 G, 106 H, 108, 108 G, 108 H, 108 GH, 109, 109 G, 110, 110 G, 110 ZL, 302, 907
51200 U	104 JH, 106, 106 A, 106 G, 106 H, 108, 108 G, 108 H, 108 GH, 109, 109 G, 110, 110 G, 110 ZL, 302, 907
51200 V	106, 106 A, 106 G, 106 H, 108, 108 G, 108 H, 108 GH, 109, 109 G, 110, 110 G, 110 ZL
51400 A	104 JH, 106, 106 A, 106 G, 106 H, 108, 108 G, 108 H, 108 GH, 109, 109 B, 109 G, 109 HA, 110, 110 G, 110 ZL, 302, 907
51400 B	104 JH, 106, 106 A, 106 G, 106 H, 108, 108 G, 108 H, 108 GH, 109, 109 B, 109 G, 109 HA, 110, 110 G, 110 ZL, 302, 907
51400 C	104 JH, 106, 106 A, 106 G, 106 H, 108, 108 G, 108 H, 108 GH, 109, 109 B, 109 G, 109 HA, 110, 110 G, 110 ZL, 302, 907
51400 D	104 JH, 106, 106 A, 106 G, 106 H, 108, 108 G, 108 H, 108 GH, 109, 109 B, 109 G, 109 HA, 110, 110 G, 110 ZL, 302, 907
51400 E	104 JH, 106, 106 A, 106 G, 106 H, 108, 108 G, 108 H, 108 GH, 109, 109 B, 109 G, 109 HA, 110, 110 G

NEEDLES (Cont'd)

APPLICATION OF TYPE NUMBERS TO MACHINES (Cont'd)

Machine Style	Type of Needles
51400 F	104 JH, 106, 106 A, 106 G, 106 H, 108, 108 G, 108 H, 108 GH, 109, 109 B, 109 G, 109 HA, 110, 110 G, 110 ZL, 302, 907
51400 G	101, 101 G, 109 B
51400 H	101, 101 G, 101 J, 104, 104 JH, 106, 106 G, 109 B
51400 J	104 JH, 106, 106 A, 106 G, 106 H, 108, 108 G, 108 H, 108 GH, 109, 109 B, 109 G, 109 HA, 110, 110 G, 110 ZL, 302, 907
51400 K	104 JH, 106, 106 A, 106 G, 106 H, 108, 108 G, 108 H, 108 GH, 109, 109 B, 109 G, 109 HA, 110, 110 G, 110 ZL, 302, 907
51400 L	104 JH, 106, 106 A, 106 G, 106 H, 108, 108 G, 108 H, 108 GH, 109, 109 B, 109 G, 109 HA, 110, 110 G, 110 ZL, 302, 907
51400 M	104 JH, 106, 106 A, 106 G, 106 H, 108, 108 G, 108 H, 108 GH, 109, 109 B, 109 G, 109 HA, 110, 110 G, 110 ZL, 302, 907
51400 N	104 JH, 106, 106 A, 106 G, 106 H, 108, 108 G, 108 H, 108 GH, 109, 109 B, 109 G, 109 HA, 110, 110 G, 110 ZL, 302, 907
51400 P	104 JH, 106, 106 A, 106 G, 106 H, 108, 108 G, 108 H, 108 GH, 109, 109 B, 109 G, 109 HA, 110, 110 G, 110 ZL, 302, 907
51400 Q	104 JH, 106, 106 A, 106 G, 106 H, 108, 108 G, 108 H, 108 GH, 109, 109 B, 109 G, 109 HA, 110, 110 G, 110 ZL, 302, 907
51400 R	104 JH, 106, 106 A, 106 G, 106 H, 108, 108 G, 108 H, 108 GH, 109, 109 B, 109 G, 109 HA, 110, 110 G, 110 ZL, 302, 907
51400 S	104 JH, 106, 106 A, 106 G, 106 H, 108, 108 G, 108 H, 108 GH, 109, 109 B, 109 G, 109 HA, 110, 110 G, 110 ZL, 302, 907
51400 T	104 JH, 106, 106 A, 106 G, 106 H, 108, 108 G, 108 H, 108 GH, 109, 109 B, 109 G, 109 HA, 110, 110 G
51400 U	104 JH, 106, 106 A, 106 G, 106 H, 108, 108 G, 108 H, 108 GH, 109, 109 B, 109 G, 109 HA, 110, 110 G, 110 ZL, 302, 907
51400 V	101, 101 G, 101 J, 104, 104 JH, 106, 106 G, 109 B
51400 W	104 JH, 106, 106 A, 106 G, 106 H, 108, 108 G, 108 H, 108 GH, 109, 109 B, 109 G, 109 HA, 110, 110 G, 110 ZL, 302, 907
51400 X	104 JH, 106, 106 A, 106 G, 106 H, 108, 108 G, 108 H, 108 GH, 109, 109 B, 109 G, 109 HA, 110, 110 G, 110 ZL, 302, 907

NEEDLES (Cont'd)

APPLICATION OF TYPE NUMBERS TO MACHINES (Cont'd)

Machine Style	Type of Needles
51400 Y	104 JH, 106, 106 A, 106 G, 106 H, 108, 108 G, 108 H, 108 GH, 109, 109 B, 109 G, 109 HA, 110, 110 G, 110 ZL, 302, 907
51400 AA	104 JH, 106, 106 A, 106 G, 106 H, 108, 108 G, 108 H, 108 GH, 109, 109 B, 109 G, 109 HA, 110, 110 G, 110 ZL, 302, 907
51400 AB	104 JH, 106, 106 A, 106 G, 106 H, 108, 108 G, 108 H, 108 GH, 109, 109 B, 109 G, 109 HA, 110, 110 G, 110 ZL, 302, 907
51400 AC	104 JH, 106, 106 A, 106 G, 106 H, 108, 108 G, 108 H, 108 GH, 109, 109 B, 109 G, 109 HA, 110, 110 G, 110 ZL, 302, 907
51600 A	104 JH, 106, 106 A, 106 G, 106 H, 108, 108 G, 108 H, 108 GH, 109, 109 B, 109 G, 109 HA, 110, 110 G, 110 ZL, 302, 907
51700 C	104 JH, 106, 106 A, 106 G, 106 H, 108, 108 G, 108 H, 108 GH, 109, 109 B, 109 G, 109 HA, 110, 110 G, 110 ZL, 302, 907
51700 D	104 JH, 106, 106 A, 106 G, 106 H, 108, 108 G, 108 H, 108 GH, 109, 109 B, 109 G, 109 HA, 110, 110 G, 110 ZL, 302, 907
51700 E	121, 121 G, 121 H, 121 J, 121 JH, 124, 124 G, 129, 129 G
51700 F	126, 126 G, 128, 128 F, 128 G, 128 H, 128 GA, 128 HA, 128 HB, 129, 129 G, 130, 130 G, 130 HA, 130 HB, 929
51700 G	104 JH, 106, 106 A, 106 G, 106 H, 108, 108 G, 108 H, 108 GH, 109, 109 B, 109 G, 109 HA, 110, 110 G, 110 ZL, 302, 907
51700 H	104 JH, 106, 106 A, 106 G, 106 H, 108, 108 G, 108 H, 108 GH, 109, 109 B, 109 G, 109 HA, 110, 110 G, 110 ZL, 302, 907
51700 J	104 JH, 106, 106 A, 106 G, 106 H, 108, 108 G, 108 H, 108 GH, 109, 109 B, 109 G, 109 HA, 110, 110 G, 110 ZL, 302, 907
51700 K	104 JH, 106, 106 A, 106 G, 106 H, 108, 108 G, 108 H, 108 GH, 109, 109 B, 109 G, 109 HA, 110, 110 G, 110 ZL, 302, 907
51700 L	121, 121 G, 121 H, 121 J, 121 JH, 124, 124 G, 129, 129 G
51700 M	126, 126 G, 128, 128 F, 128 G, 128 H, 128 GA, 128 HA, 128 HB, 129, 129 G, 130, 130 G, 130 HA, 130 HB, 929
51700 N	104 JH, 106, 106 A, 106 G, 106 H, 108, 108 G, 108 H, 108 GH, 109, 109 B, 109 G, 109 HA, 110, 110 G, 110 ZL, 302, 907
51700 P	104 JH, 106, 106 A, 106 G, 106 H, 108, 108 G, 108 H, 108 GH, 109, 109 B, 109 G, 109 HA, 110, 110 G, 110 ZL, 302, 907

## NEEDLES (Cont'd)

### APPLICATION OF TYPE NUMBERS TO MACHINES (Cont'd)

Machine Style	Type of Needles
51700 Q	104 JH, 106, 106 A, 106 G, 106 H, 108, 108 G, 108 H, 108 GH, 109, 109 B, 109 G, 109 HA, 110, 110 G, 110 ZL, 302, 907
51700 R	104 JH, 106, 106 A, 106 G, 106 H, 108, 108 G, 108 H, 108 GH, 109, 109 B, 109 G, 109 HA, 110, 110 G, 110 ZL, 302, 907
51700 T	126, 126 G, 128, 128 F, 128 G, 128 H, 128 GA, 128 HA, 128 HB, 129, 129 G, 130, 130 G, 130 HA, 130 HB, 929
51700 U	126, 126 G, 128, 128 F, 128 G, 128 H, 128 GA, 128 HA, 128 HB, 129, 129 G, 130, 130 G, 130 HA, 130 HB, 929

### ORDERING REPAIR PARTS

#### PLATES

Illustrations of parts are arranged according to scale and, wherever possible, parts similar in appearance or function are grouped together.

When a given design of part is made in two or more sizes, only one illustration is usually shown. In ordering these pieces, it is necessary that the additional information be furnished as requested under these illustrations.

#### LIST OF PARTS

Turning from the plates to the list of parts, the description of each part and its principal uses will be found. Always check the symbol against its description before ordering. It is not necessary to furnish the plate number.

When a part is used, or can be used, in all machines covered by this catalog, no specific use is mentioned in the description.

For convenience in ordering, minor parts such as screws, nuts and similar articles are repeated after each major part.

(-) A dash in the "plate number" column of the list of parts indicates the absence of an illustration.

(‡) A double dagger in the "symbol to order by" column indicates that the component parts cannot be furnished separately. Due to the high speed of these machines and other factors it is impossible for these associated parts to be fitted a second time and make a serviceable job.

#### IDENTIFYING PARTS

Where the construction permits, each part is stamped with its part number. Some of the smaller parts are stamped with an identification letter to distinguish them from parts similar in appearance.

## ORDERING REPAIR PARTS (Cont'd)

### IDENTIFYING PARTS (Cont'd)

All part numbers represent the same part, regardless of the catalog in which they appear.

### SUPPLIES

All supplies, including taps, reamers, belting, belt hooks, belt fasteners, screw drivers, wrenches and powdered oil stone will be promptly furnished.

### USE GENUINE NEEDLES AND REPAIR PARTS

Success in the operation of these machines can be secured only by the use of genuine Union Special Needles and Repair Parts as furnished by the Union Special Machine Company, its subsidiaries and authorized distributors. They are designed according to the most approved scientific principles, and are made with the utmost precision. The maximum efficiency and durability are assured.

Genuine needles are put up in packages marked at the top "Trade 'UNION SPECIAL' mark". Genuine repair parts are stamped with a reproduction of the familiar Union Special padlocks.



Each trade mark is your guarantee of the highest quality in materials and workmanship.

### TERMS

Prices are strictly "net cash" and subject to change without notice. All shipments are forwarded at the buyer's risk F.O.B. shipping point. Parcel post shipments are insured unless otherwise directed. A charge is made to cover the postage and insurance.

Plate 1 - Full Size



112

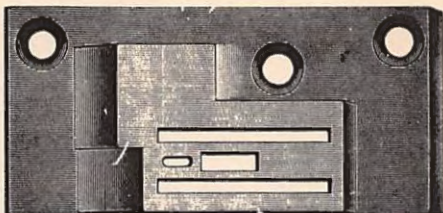

9724

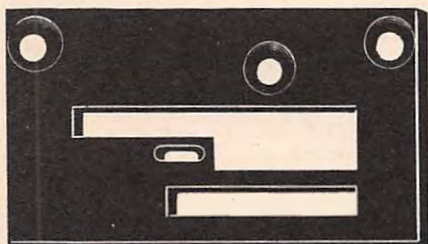

6424W

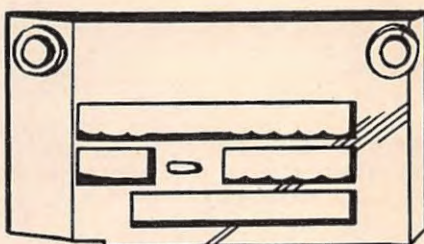

K60093

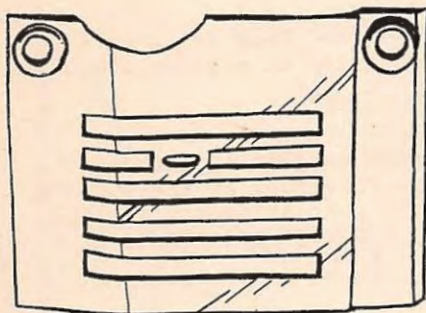

6428L

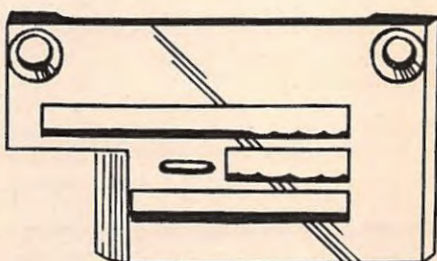

K60150

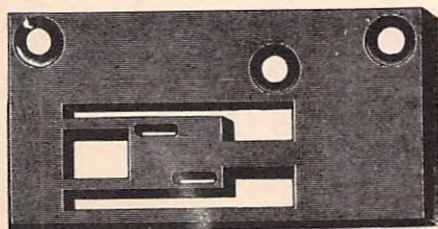

7024C  
Specify Gauge

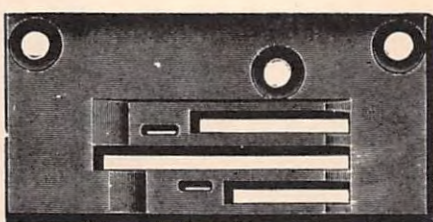

7424B  
Specify Gauge



Plate 2 - Full Size

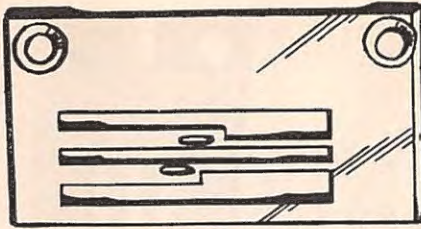

8328 C-3

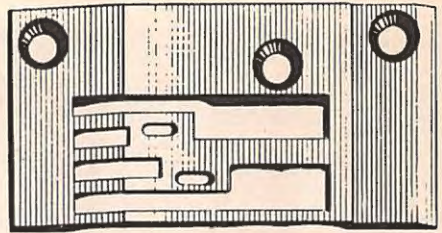

7528H-4 1/2

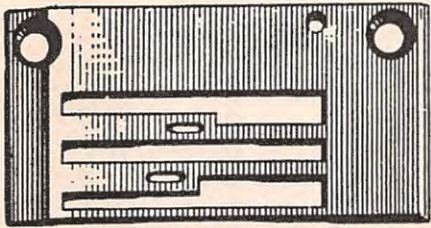

8324 L  
Specify Gauge

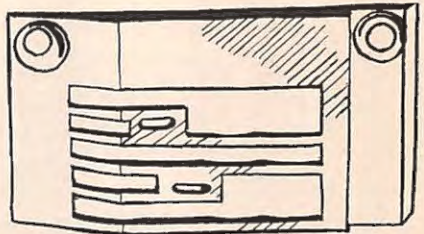

7424 AF  
Specify Gauge

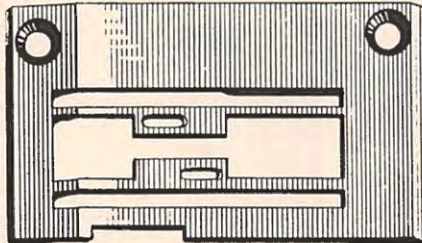

7424AG-5

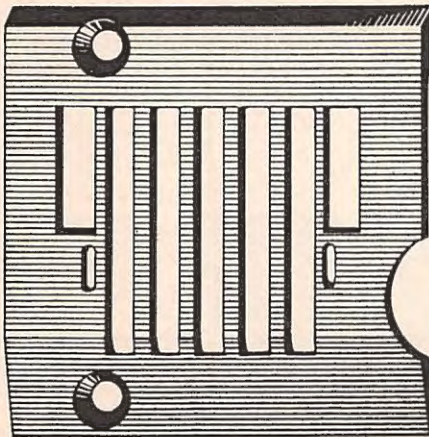

16524 B  
Specify Gauge

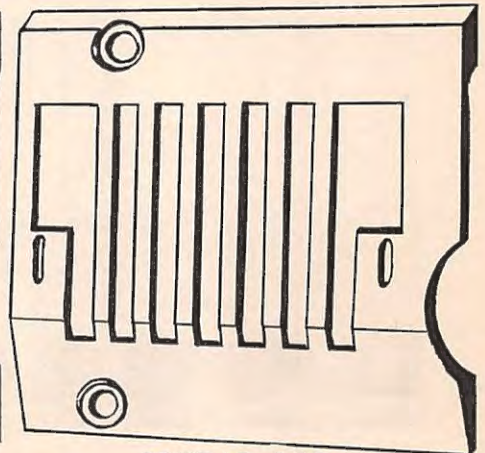

51724G-128

Plate 3 - Full Size

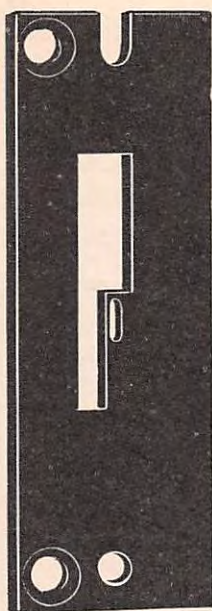

51224D

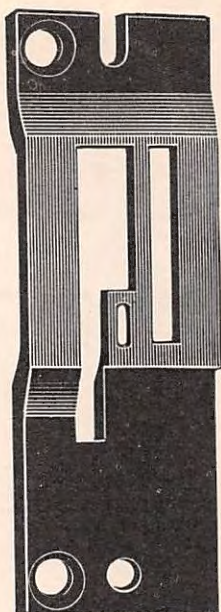

51224B

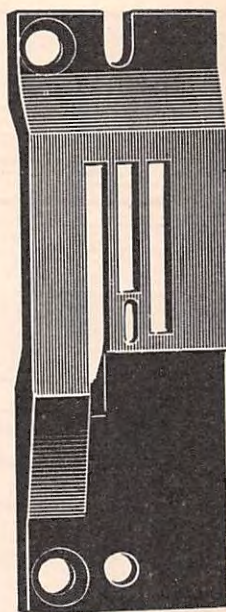

51224A

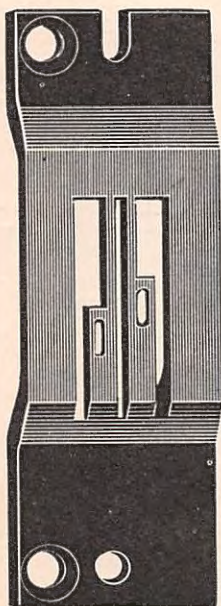

51424  
Specify  
Gauge

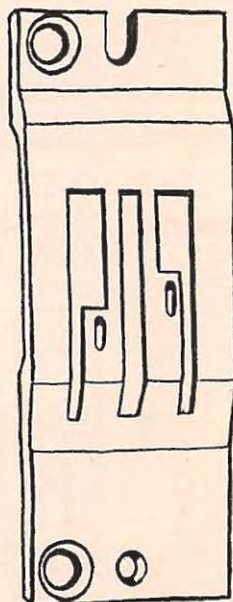

51424K  
Specify  
Gauge

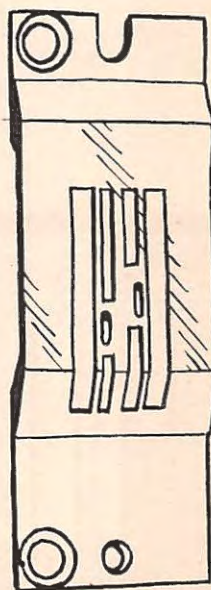

51424 A  
Specify  
Gauge

Plate 4 - Full Size

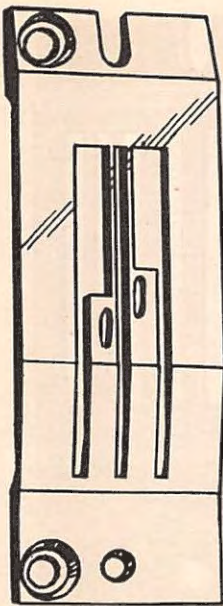

K59500

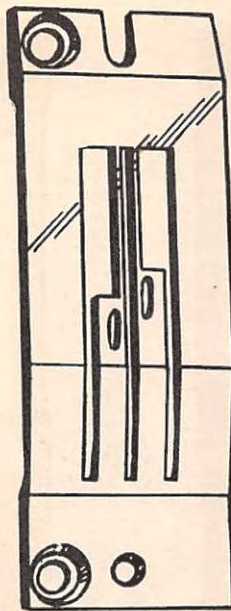

K59502

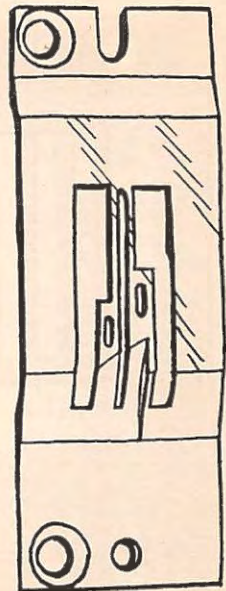

51424 E  
Specify  
Gauge

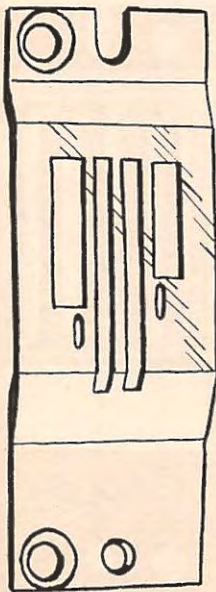

51424 F-32

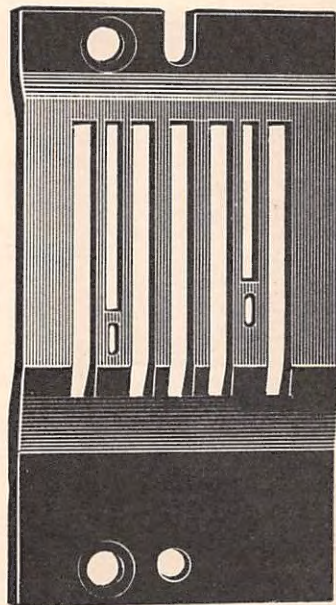

51424 C-48

Plate 5 - Full Size

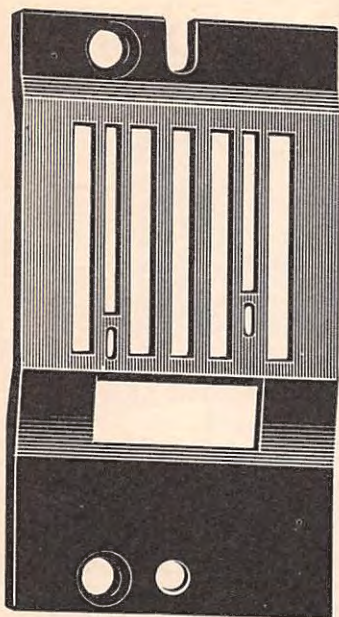

51424B  
Specify  
Gauge

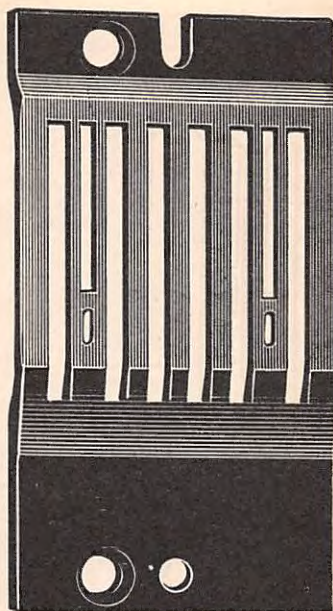

51724  
Specify  
Gauge

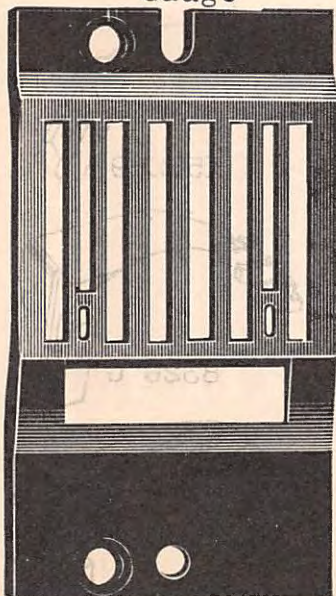

51724D  
Specify  
Gauge

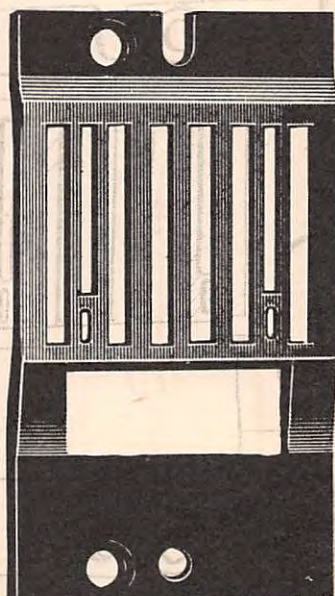

K59843

Plate 6 - Full Size

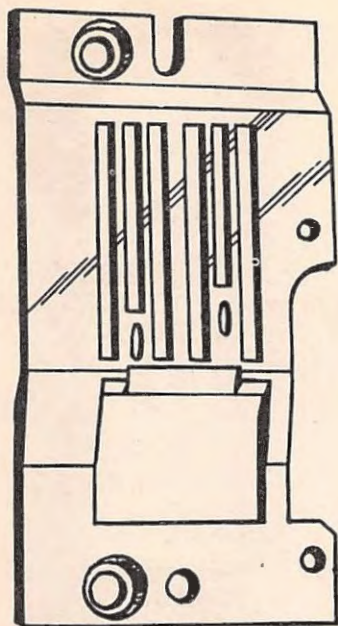

K54259

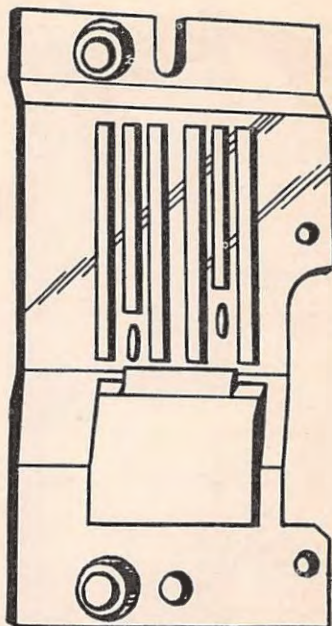

K53843

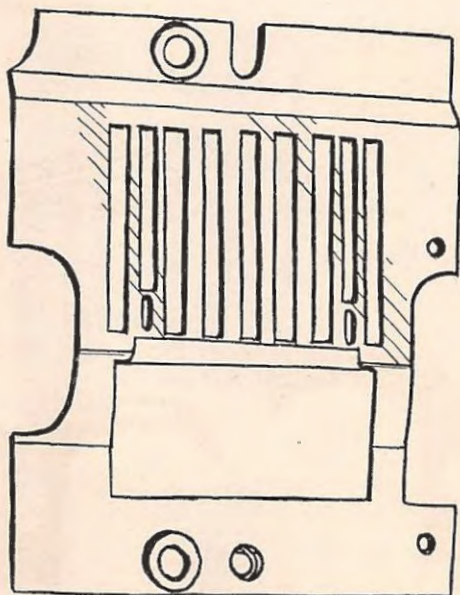

51724 E  
Specify Gauge

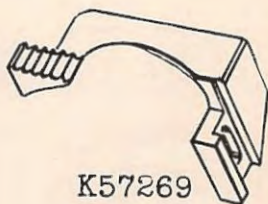

K57269

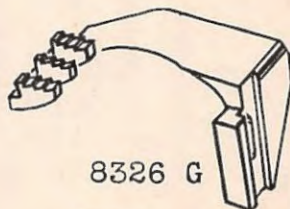

8326 G

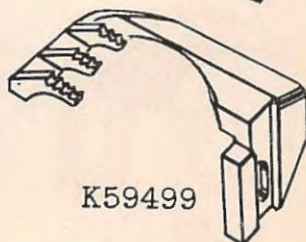

K59499

Plate 7 - Full Size

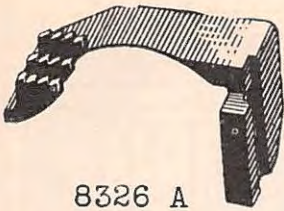

8326 A

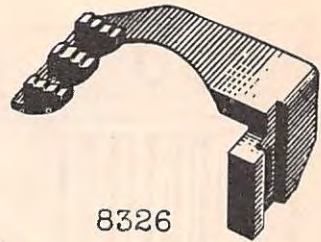

8326

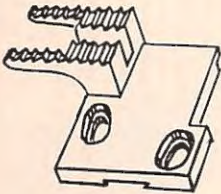

15105 B

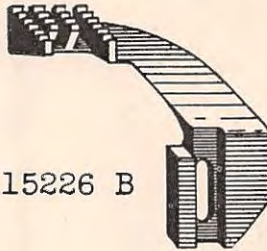

15226 B

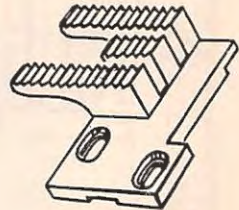

K60151

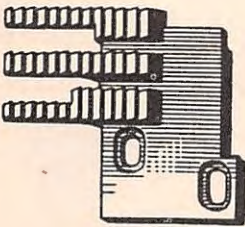

8305 L

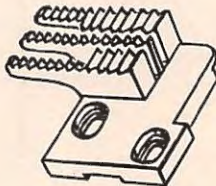

K59498

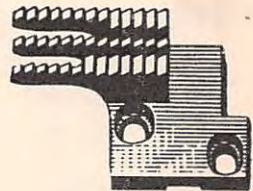

8305 S



7005A  
Specify  
Gauge

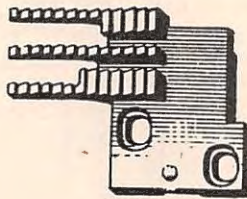

8305 N

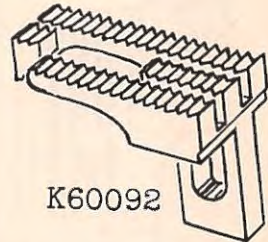

K60092

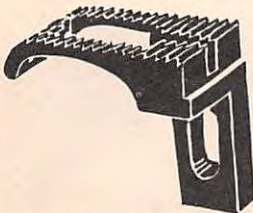

7405U-4 1/2



22 I



51405 A  
Specify  
Gauge

Plate 8 - Full Size

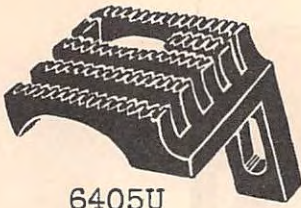

6405U

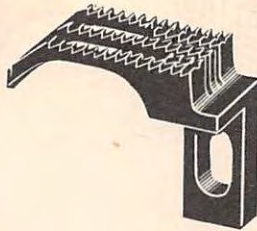

51405-16

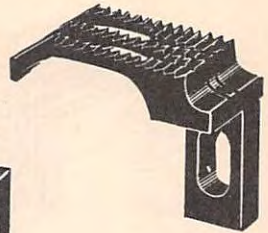

51405E  
Specify  
Gauge

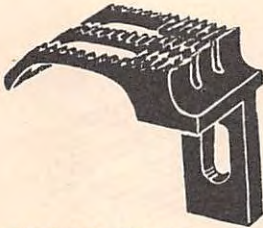

51405 K-26

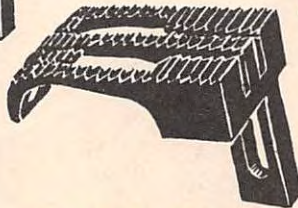

7405AF-5 1/2

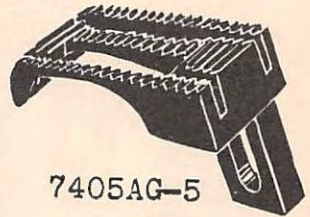

7405AG-5



51205D

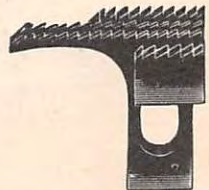

7405B-6

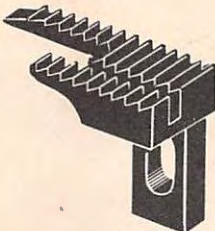

6405M



9705



51205A



51405B-32

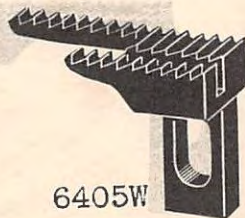

6405W



51405F-32

Plate 9 - Full Size

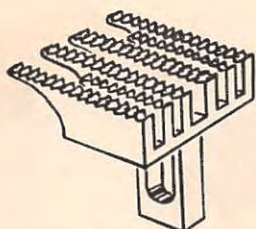

K53844

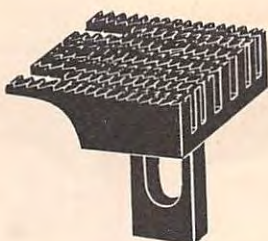

51405B-48

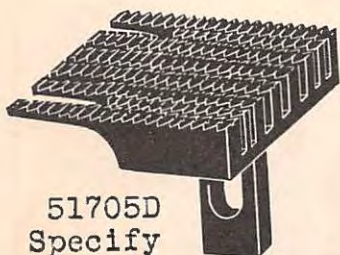

51705D  
Specify  
Gauge

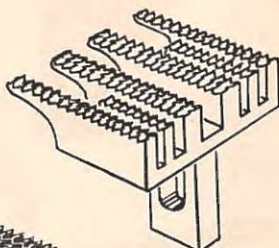

K54260

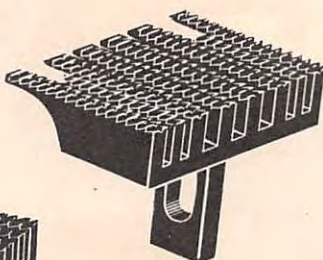

51705  
Specify  
Gauge

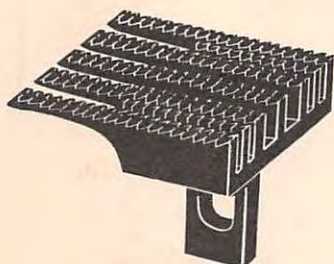

51405C-48

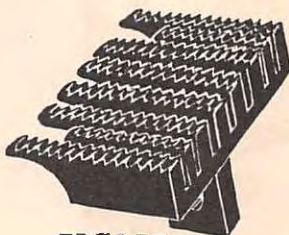

51705E  
Specify  
Gauge

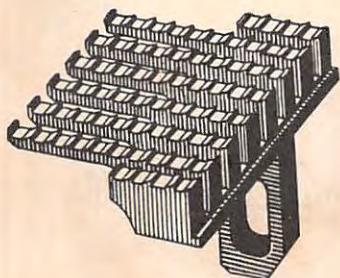

16505  
Specify  
Gauge

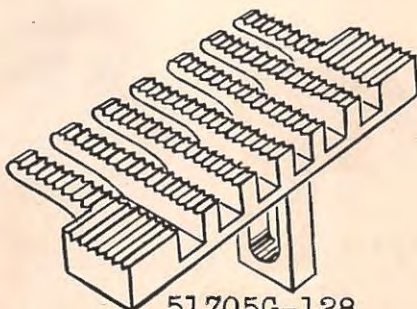

51705G-128



Plate 10 - Full Size



1727A



6420W



65A

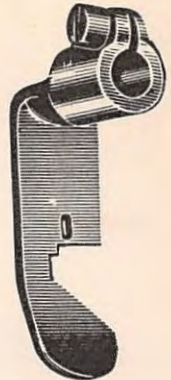

51220A

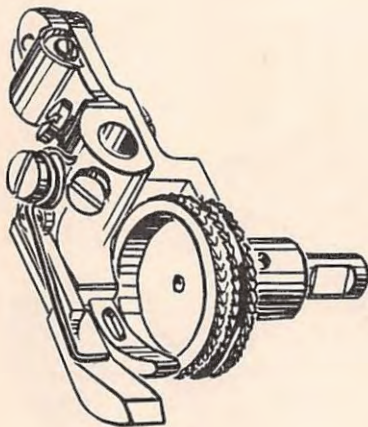

K59088

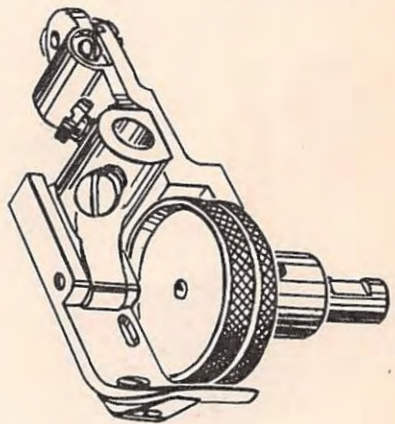

K57279



9720



51220J

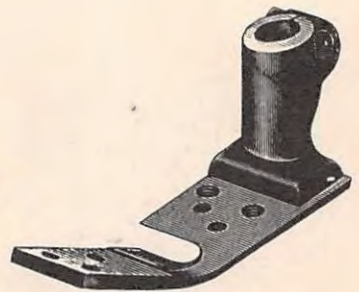

9420 C  
Specify  
Gauge

Plate 11 - Full Size

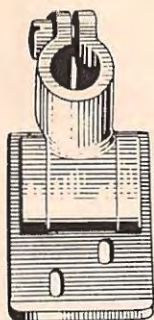

51420 K-26

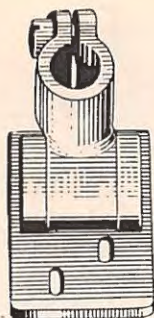

7420AG  
Specify  
Gauge



198 B-6  
Specify  
Gauge



7020B  
Specify  
Gauge

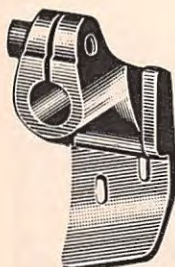

51420  
Specify  
Gauge

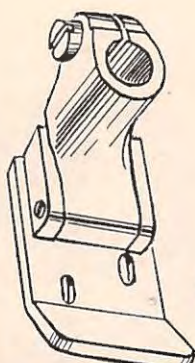

K52033

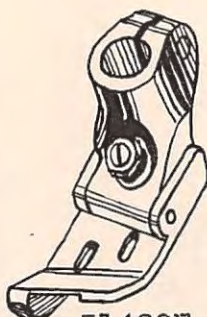

51420E  
Specify  
Gauge

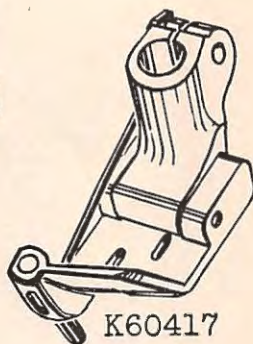

K60417



K60419

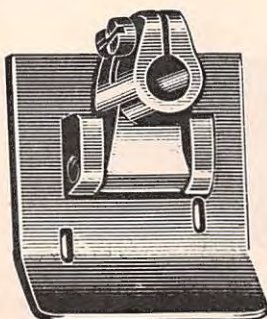

51420C  
Specify  
Gauge

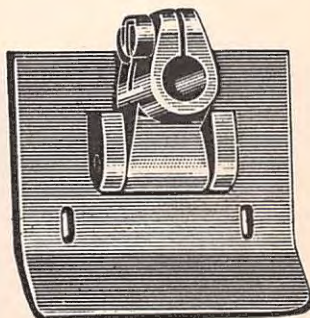

51720 D  
Specify  
Gauge

Plate 12 - Full Size

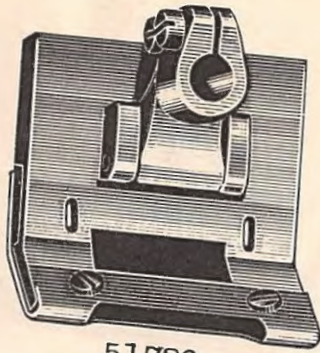

51720  
Specify  
Gauge

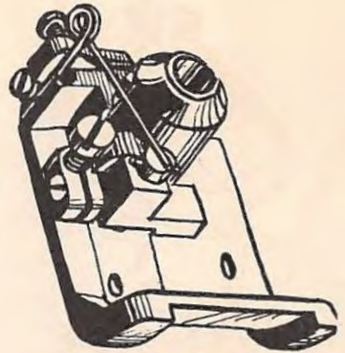

51420M-48

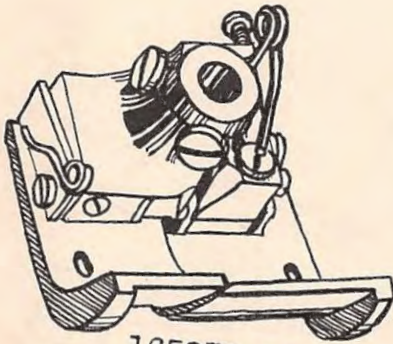

16527B-88

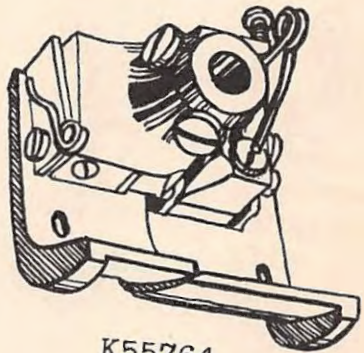

K55764

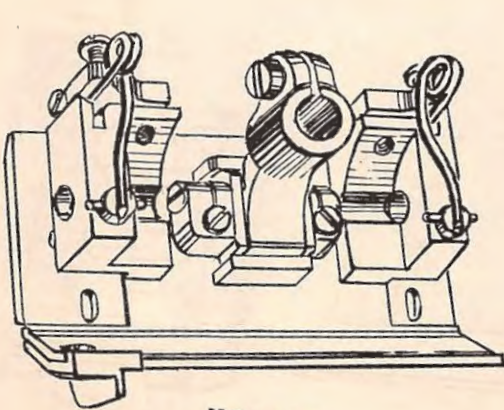

K50410

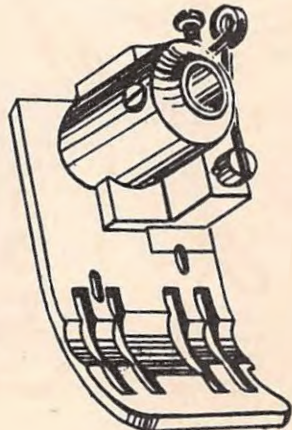

K53842

Plate 13 - Full Size

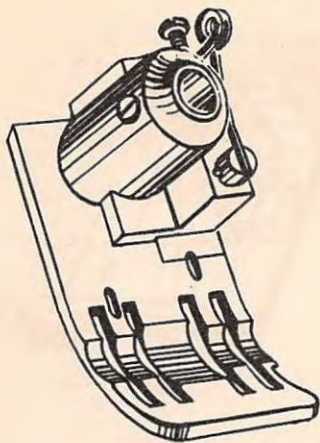

K54258

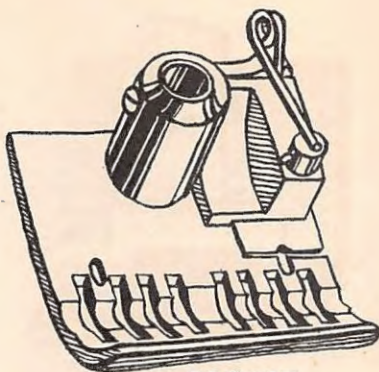

51720E  
Specify  
Gauge



51430A  
Specify  
Gauge

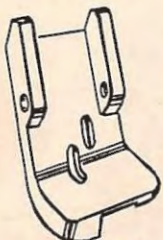

51430E  
Specify  
Gauge

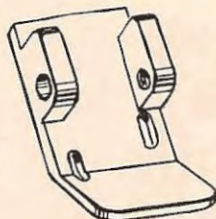

51430C  
Specify  
Gauge

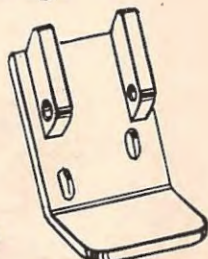

51430K-26



K57282



9733

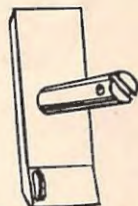

51430N-48



51730F  
Specify  
Gauge

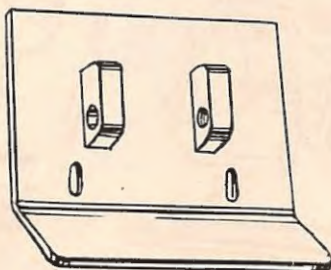

51730D  
Specify  
Gauge

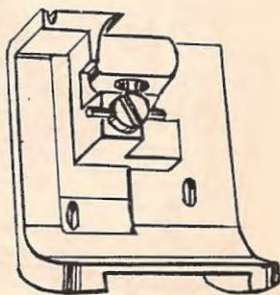

51430M-48

Plate 14 - Full Size

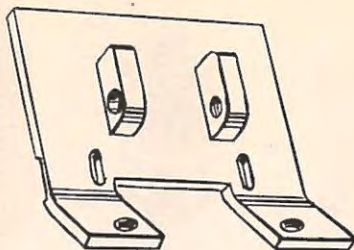

51730  
Specify  
Gauge

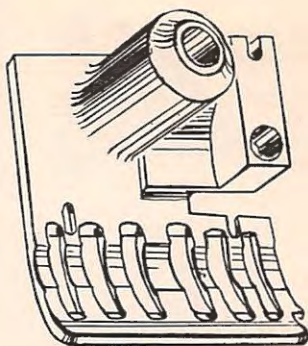

51730E  
Specify  
Gauge

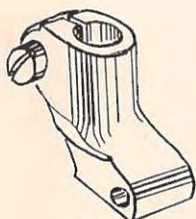

51430B

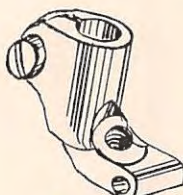

51430D

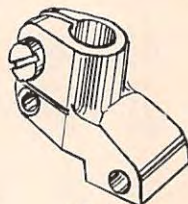

51430



51430G

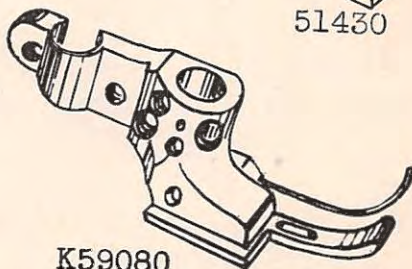

K59080

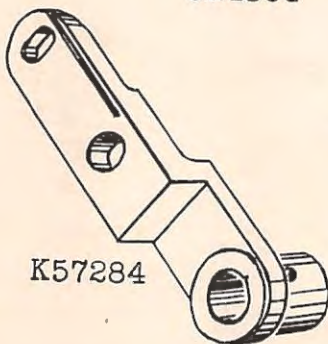

K57284

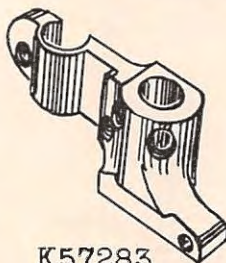

K57283



1741B



9634A



K57342

Plate 15 - Full Size

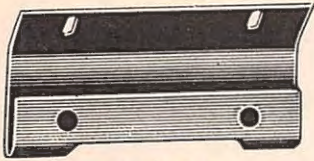

51730A  
Specify  
Gauge



K53845



K54261



K53848



K53846



51774D

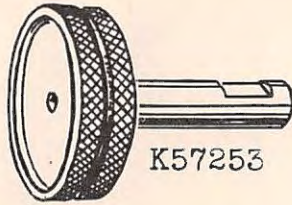

K57253

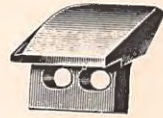

9755



16194B

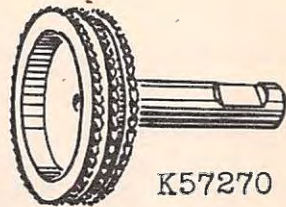

K57270



51777D



K53850



51708



K53890



K57667



K56823



K57818



K55001

Plate 16 - Full Size



51709



51408  
Specify  
Gauge



51408A-16



K57668



K53891



51208



51208D



51909B



51409



51409B



K58494



K59002



51225



51425



51525



51725E

Plate 17 - Full Size

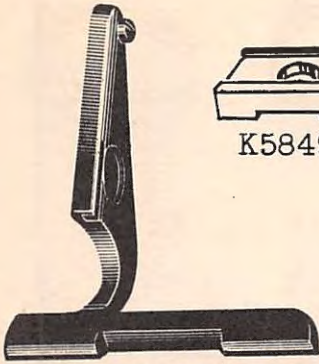

51725



K58495

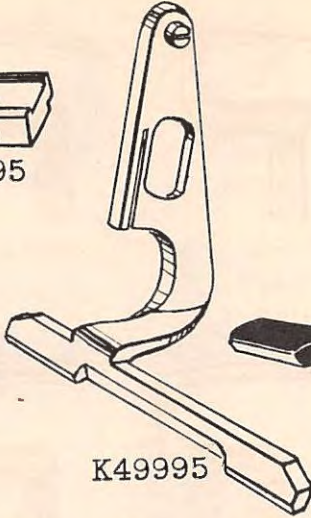

K49995



51725A



5650



51134G



51418-16



13153



51418 K  
Specify  
Gauge



7018E  
Specify  
Gauge



51418B  
Specify  
Gauge



8118-64



16152  
Specify  
Gauge



7040  
Specify Gauge



7933  
Specify  
Gauge



51759 A



51758A



57 WB



Plate 18 - Full Size



1287



1288



109



109B



1346



51292



107



51959B

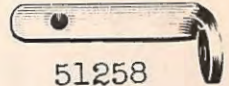

51258



52A



158B

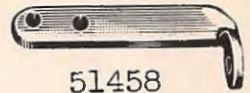

51458



51258A



51292D



51758



52958



51458A



51292 E



668-13



668-12

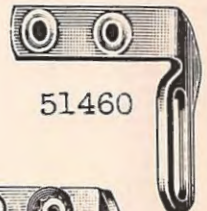

51460



51460A



668-7



668-1



668-14



51292A



51491C

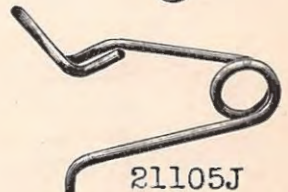

21105J

Plate 19 - Full Size

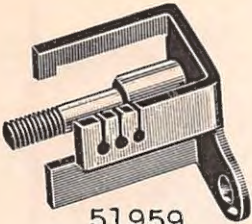

51959



51459A



51462B



51404

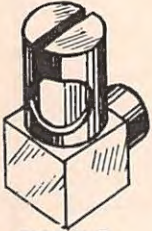

39193



39193 A



39193B



666-49



12964C



28619



660-95



666-50

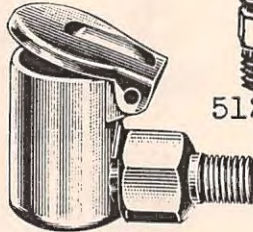

666-28



51294F



61294 W



52894 Z



666-13



666-82

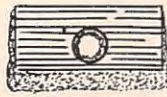

51245 A



660-75



666-19

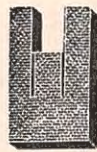

660-90



1248



666-66



51243E

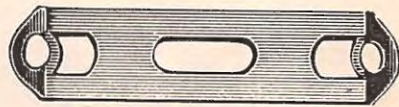

51243R

Plate 20 - Full Size



Plate 21 - Full Size

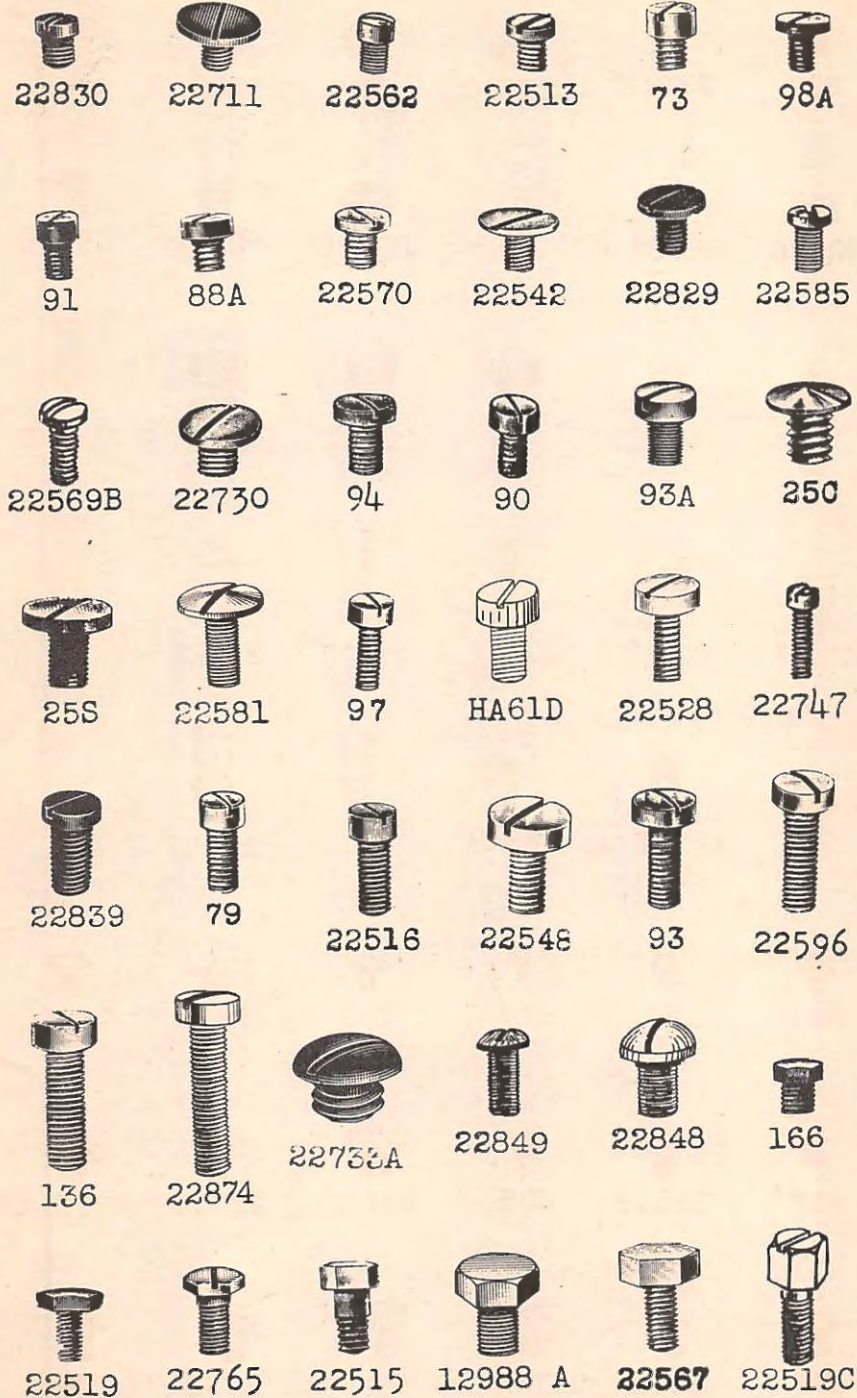

Plate 22 - Full Size



627



22864



22882A



22868A



12993A

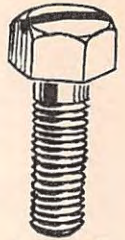

22788



22632F-24



22507



22508



22509



69FD

22716A



22716



87



87 A



22524



538



22521



80



22769



22574



226



223C



22726



134



57WD



22735



22797



22593



15872D



22772



86



22758B



15438D



22585B



22585A



86X

Plate 23 - Full Size



22872



22778



22594



97A



22799



22517



22557



22773



22559A



22504



22569



9663

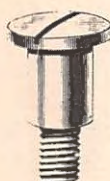

236



22794B



75A



22559C



22587



22559B



74



22810



318



22799 N



22845B



22801



22799G



402



22799 P



T2



22799B



22799E



J42JK



22799D



1332

Plate 24 - Full Size

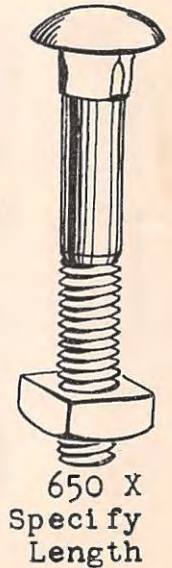
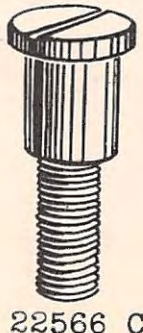
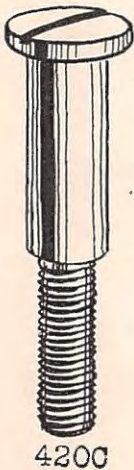
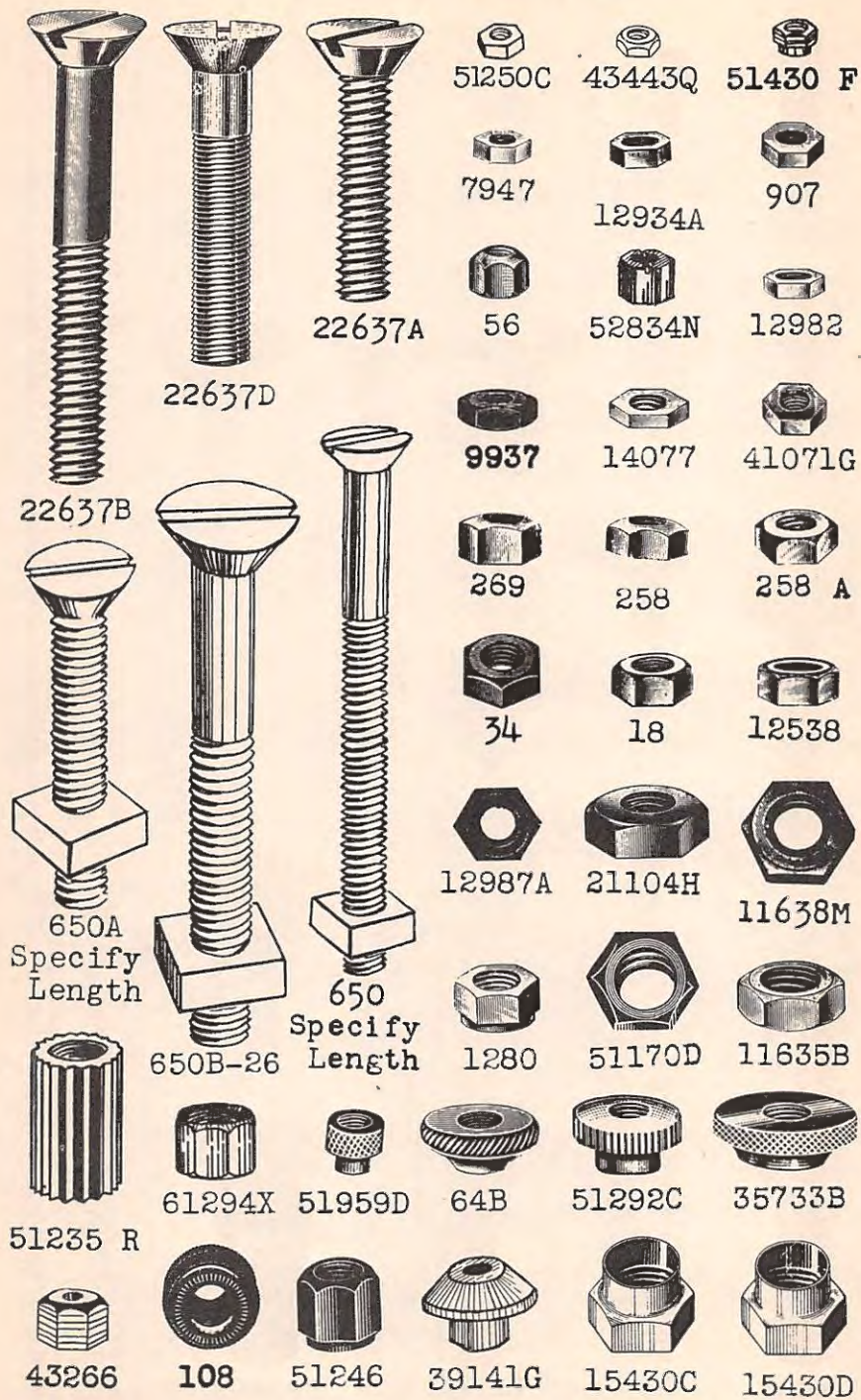

Plate 25 - Full Size



22637B

22637D

22637A

51250C

43443Q

51430 F

7947

12934A

907

56

52834N

12982

9937

14077

41071G

269

258

258 A

34

18

12538

12987A

21104H

11638M

650A  
Specify  
Length

650B-26

650  
Specify  
Length

1280

51170D

11635B

51235 R

61294X

51959D

64B

51292C

35733B

43266

108

51246

39141G

15430C

15430D



Plate 26 - Full Size

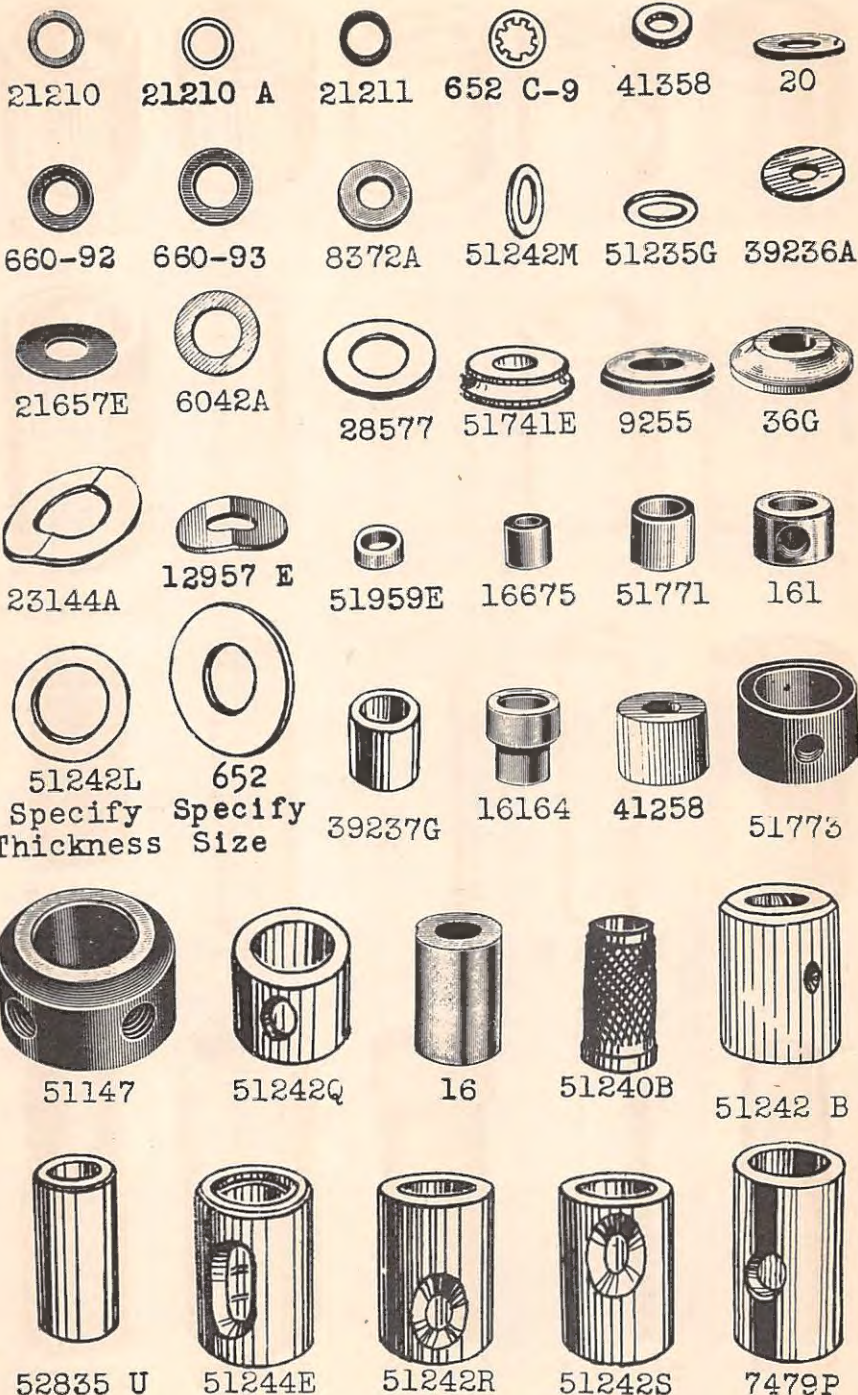

Plate 27 - Full Size



51250B



51290

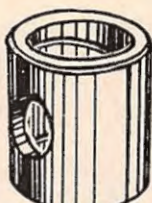

51290D



51290 K



51290 M



51290 E

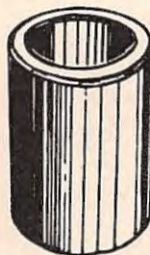

51290 J



52889



51254A



51290 L



51290A



52835 W



53556C



51257D



21113B



51254



51257 C



51244C



51250A



51257A

Plate 28 - Full Size



51774H



51777H



51751



51244B



15465F



51283F



52835 G



51770  
Specify  
Gauge



51243C

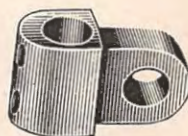

35759

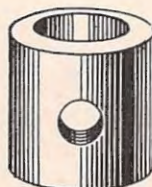

43C



43



8372



51582

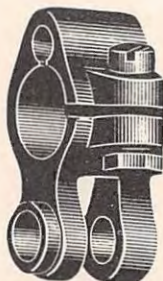

51236



51245

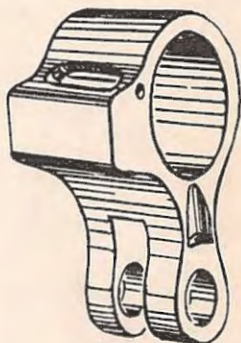

51145

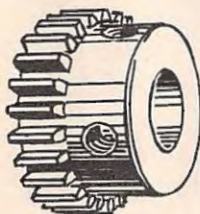

51239 D

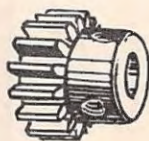

51239 E



51775

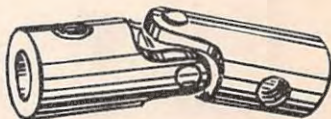

51239 G

Plate 29 - Full Size

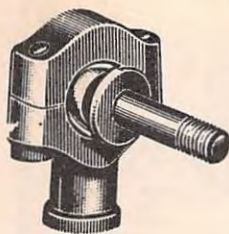

55641

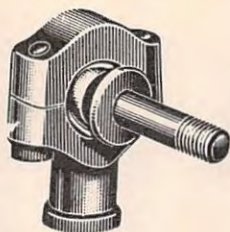

51741



51741B



51239 L

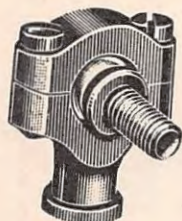

51241D

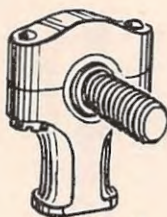

55241N

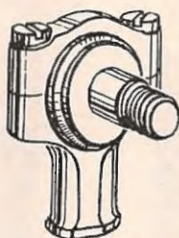

51741C

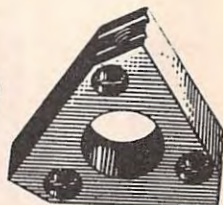

41258 E



41258B



50J-16



16676



1740



43281 L



50J-40



61267G



52841



HA1286



1286



1286 A



51461C



51236A



51239 B



51283B



35167 B



667D-16



14786A



39132V



51296A



51296

Plate 30 - Full Size



51236C



51239 H



39237



51243B

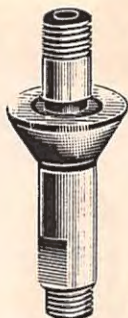

51745

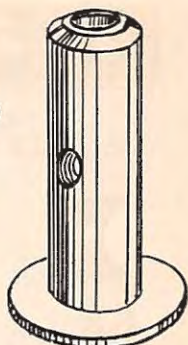

21172L



V118



52887 N



41047



4761



51240A



51492



52835 S



39236



51239 F



21693H



K57272

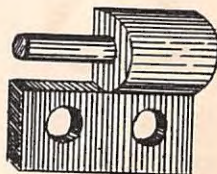

52885G



51239 C



39237D

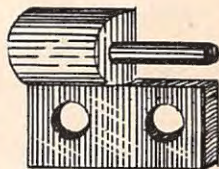

52885H

Plate 31 - Full Size



35731A



51236B



51461B



7486PA



51293B



52887G

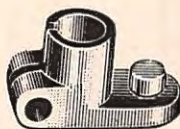

21657B



51235 M



358 B



21350



8344



51235 Q



52835 Q



51235 N



660-127



380



21351

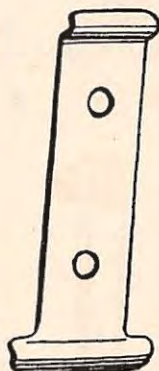

23447C

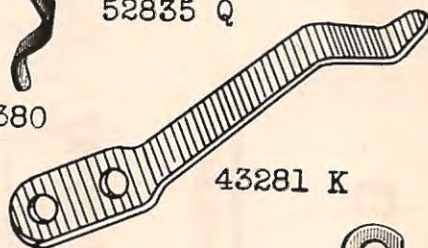

43281 K



23449C



23425T

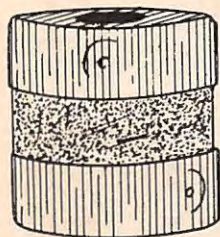

51295



21225  
Specify  
Measurement

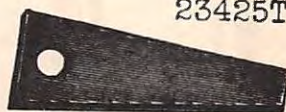

7459A

Plate 32 - Full Size

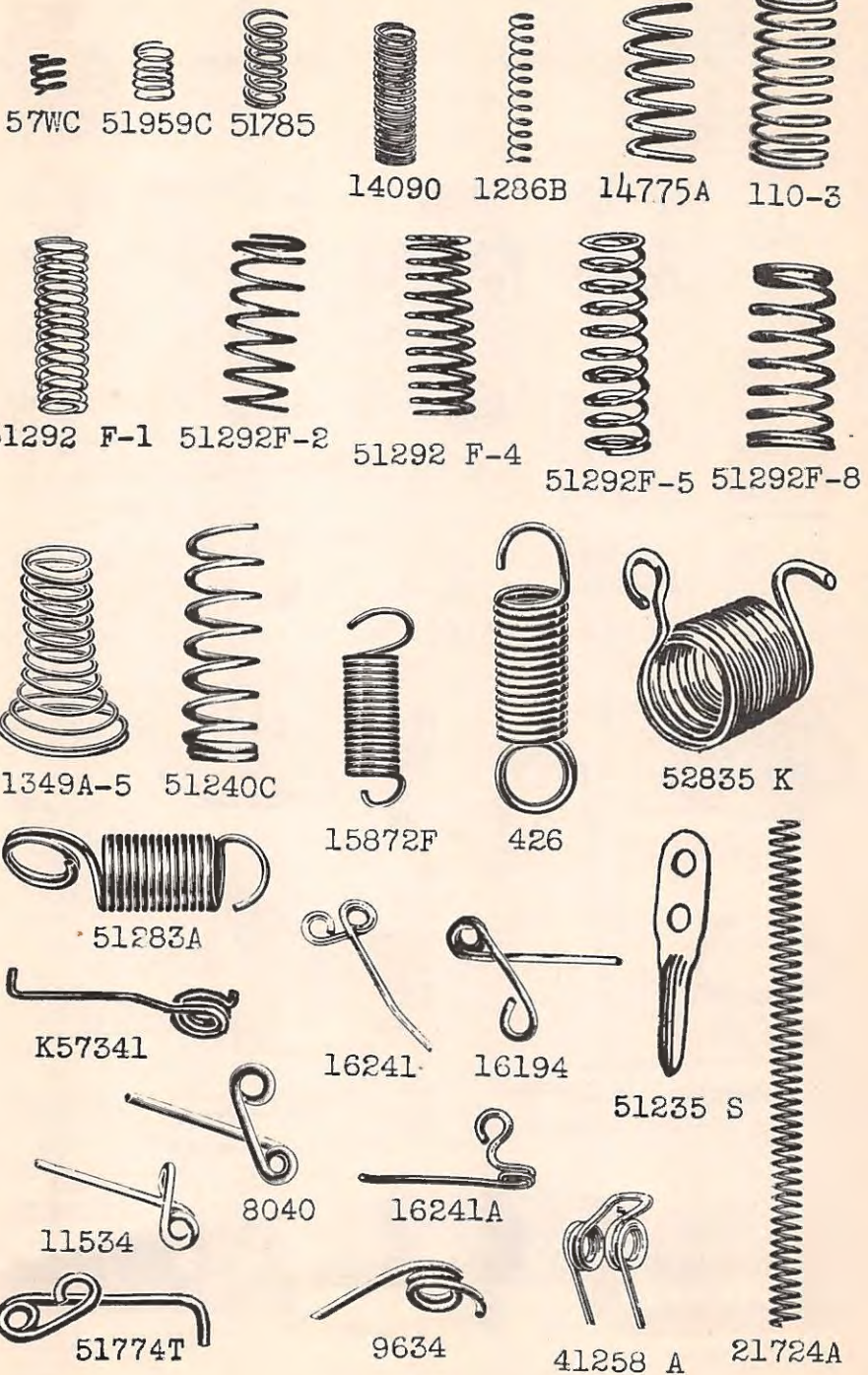
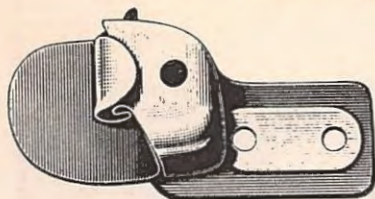

Plate 33 - One-half Size



23420 U  
Specify Gauge  
and Capacity



23421U  
Specify Gauge  
and Capacity



23253B



K6805



23421V  
Specify Gauge  
and Capacity

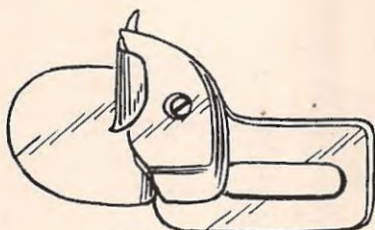

23420V  
Specify Gauge  
and Capacity

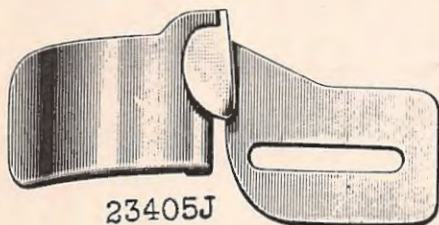

23405J

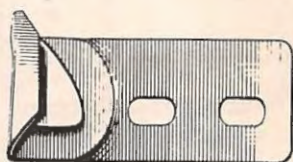

23253F

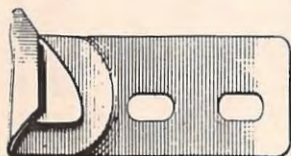

K6806

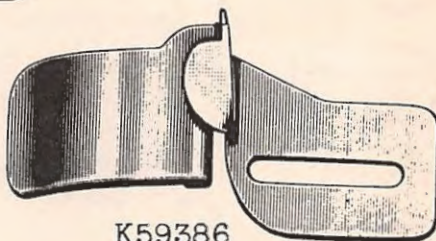

K59386



24 X



24

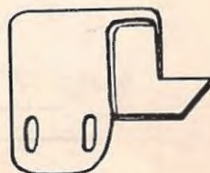

K58111



Plate 34 - One-half Size

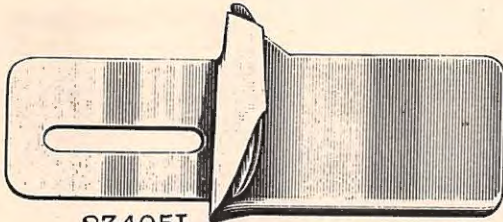

23405L

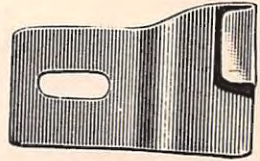

23404B

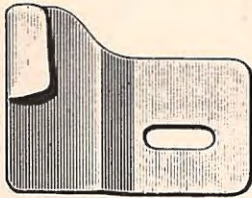

23404E

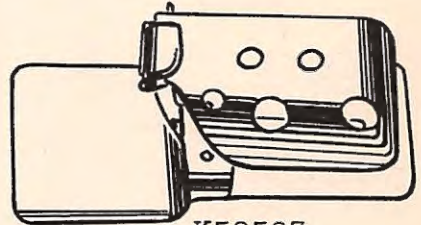

K59503

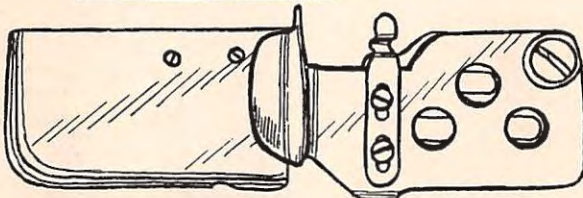

23449



23425V



23425U

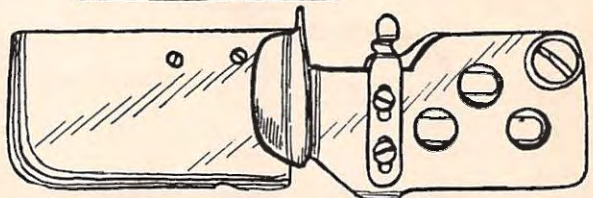

K53852

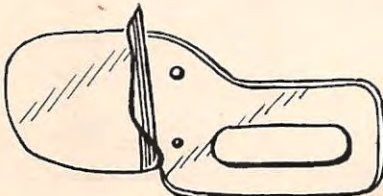

23422U

Specify Capacity

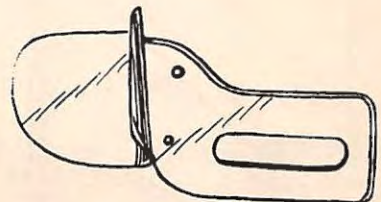

23422 V-1/32

Plate 35 - One-half Size

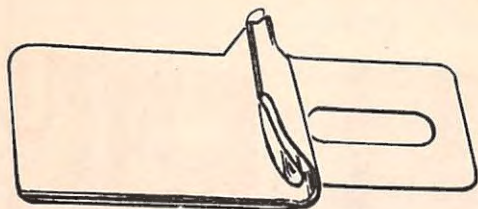

K59432

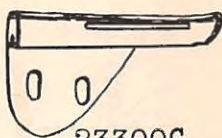

23300G

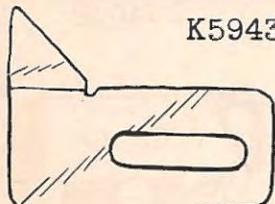

23438A

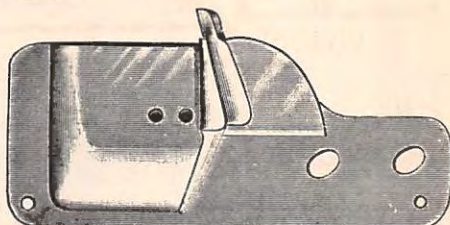

23100

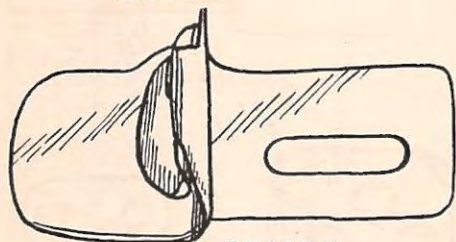

23405N

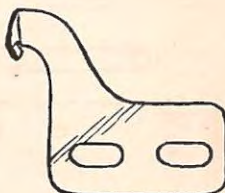

7403P



2603K

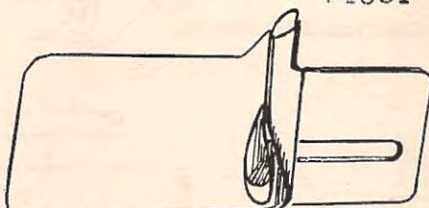

23405F

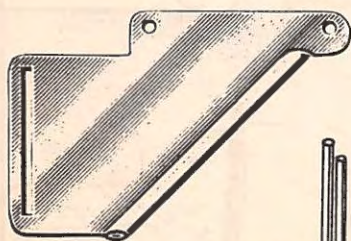

23403  
Specify  
Gauge



23324J



23438B

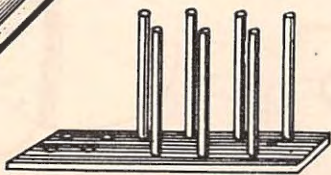

23439 A



23447A



23449B

Plate 36 - One-half Size

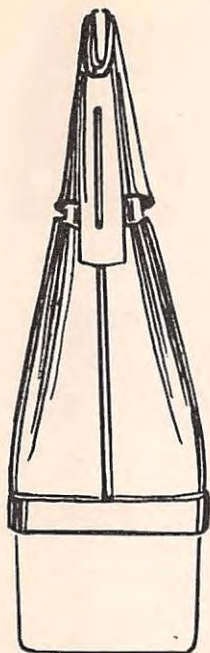

K58001



K53941



23447  
Specify  
Gauge



K53853



23322AB

Specify Width of  
Binding Strip



23215BC

Specify Width of  
Binding Strip

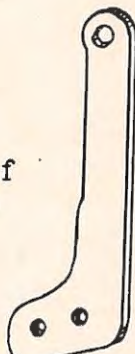

23229N



K56034



51420L-32



23437A



23322AC

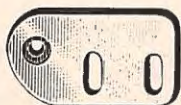

23437B



23324G

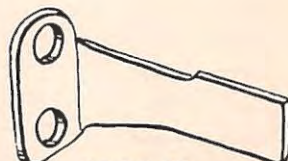

52864N

Plate 37 - One-half Size



23229M

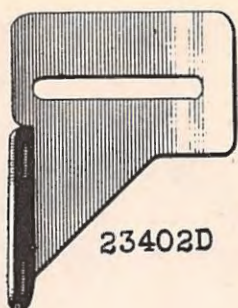

23402D

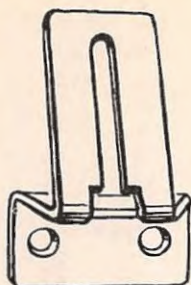

23447B



23436



K60416



23432

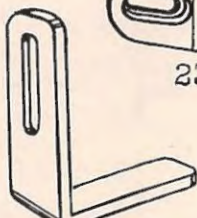

23229P



23432A



23229Q

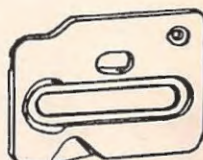

23449A



K60418



K54262



K53851

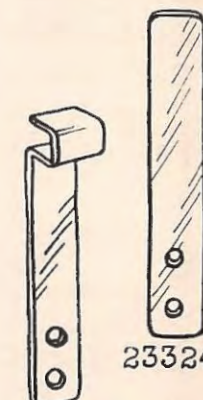

23324V



51777  
Specify  
Gauge



23324H



51774P



23324U

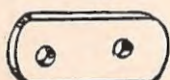

K55310



K53855



K51165

Plate 38 - One-half Size

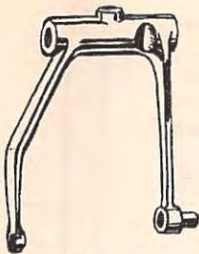

51774L



K53847



51774N



51777L

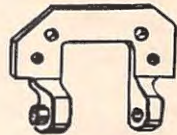

K53849

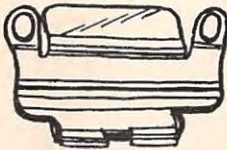

K53854

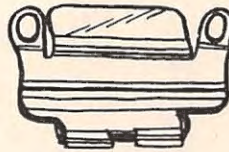

K54264

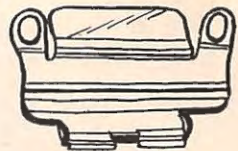

23448  
Specify  
Gauge



51776



51774  
Specify  
Gauge

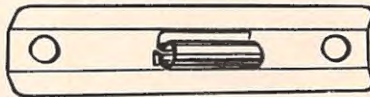

21182K



243



21182L



53592

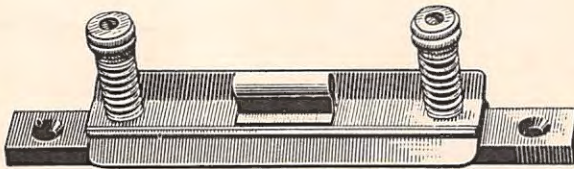

21182N



21182T



21182P

Plate 39 - One-half Size

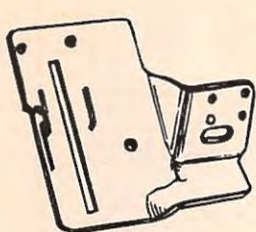

51457A



51757A



52857B



51423



51704



52804



52804A



21657J



51423B



51170 F



51270B



21657-2



21657-4



51723 A



52883G



35833C



16182C



21657M



16182B



21657C



21657D



52887

Plate 40 - One-half Size



29105 A



29105 B

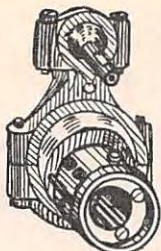

29105L

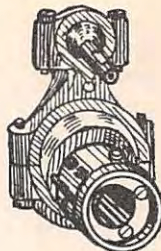

29105M



29105P



29105Q

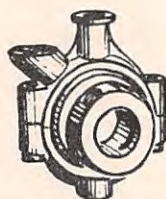

29114 A

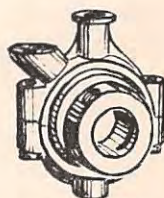

29114B



29138 H

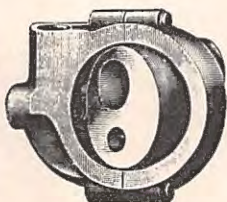

29138 J

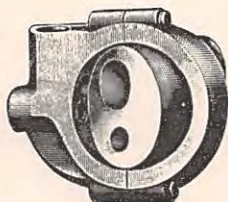

29138 K

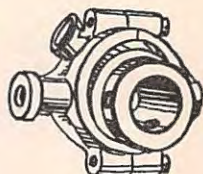

29138M

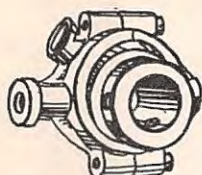

29138Q

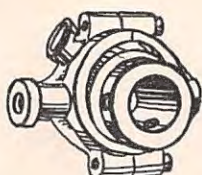

29138R

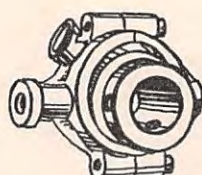

29138S



29066F

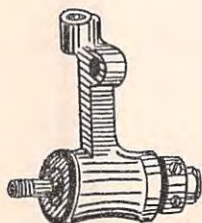

29192

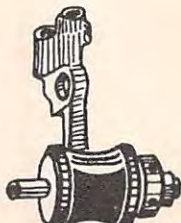

29192 A

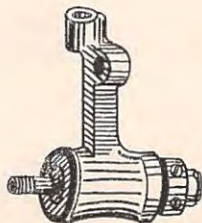

29192 C



29192 D

Plate 41 - One-half Size



51213



51413



51513



51713



51216A



51244

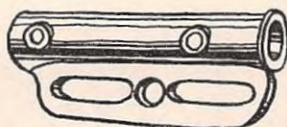

51744A



52944G



54



51772  
Specify  
Gauge



51241

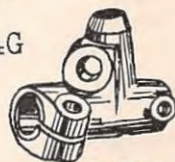

51242K



51241G

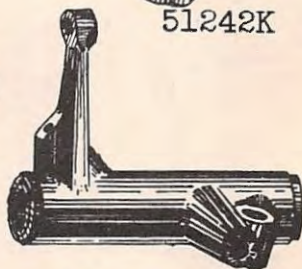

51242T

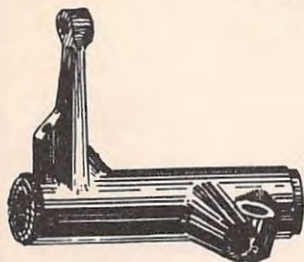

51242U



51243K



51243L



51243N



51235A



52836C



51242N



51242V



Plate 42 - One-half Size

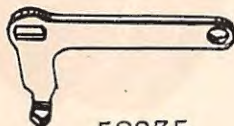
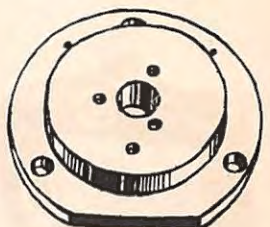
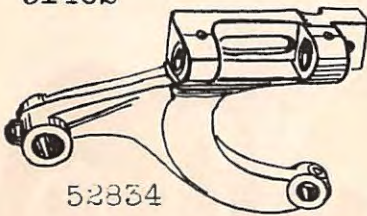
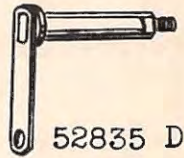
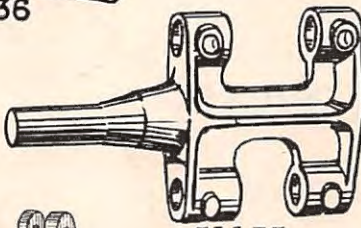
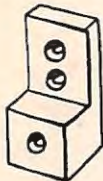
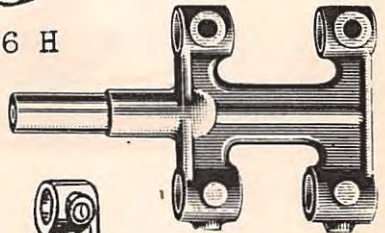
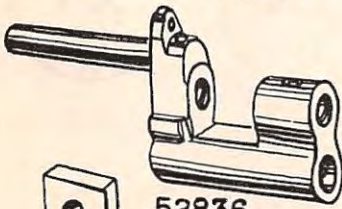
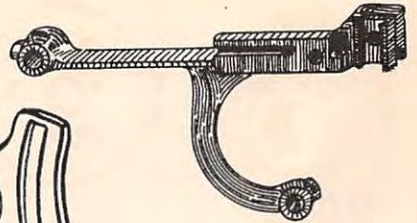
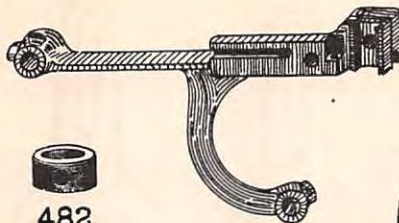
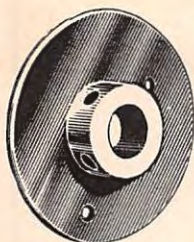

Plate 43 - One-half Size



51461A



51239 A



K57257



41258 CG



7485P

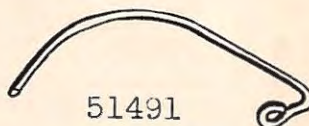

51491



7487 Q

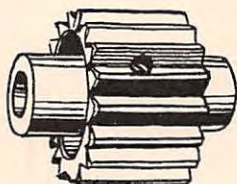

7490P



51235 P



7491P

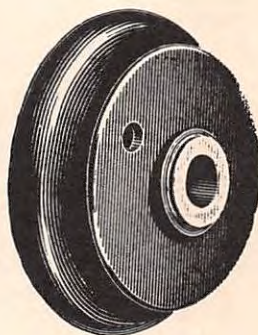

51221



7481P

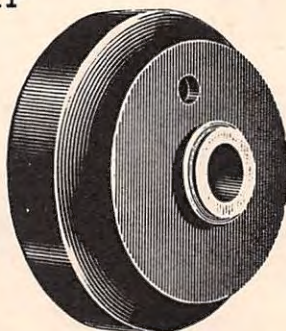

51321A

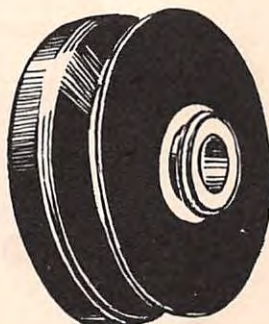

51321B



51217



51217 A



51417  
Specify  
Gauge



51417B

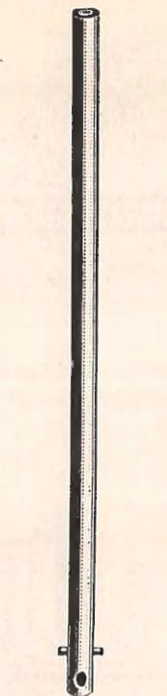

51517-16



51517A

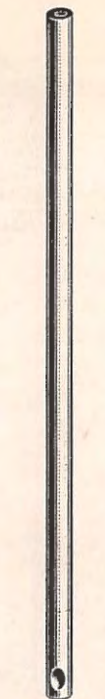

51717



K53889



K56824



K57666



K57819



52888

Plate 45 - One-half Size



21113A



51244A



7476P



8



21657L



21657A

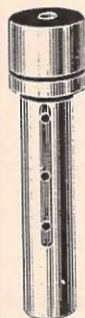

51250



51462C



21657P



51242A



51235B



51242H



43134D



424



39135



52834G



7489P



21723C

Plate 46 - One-half Size

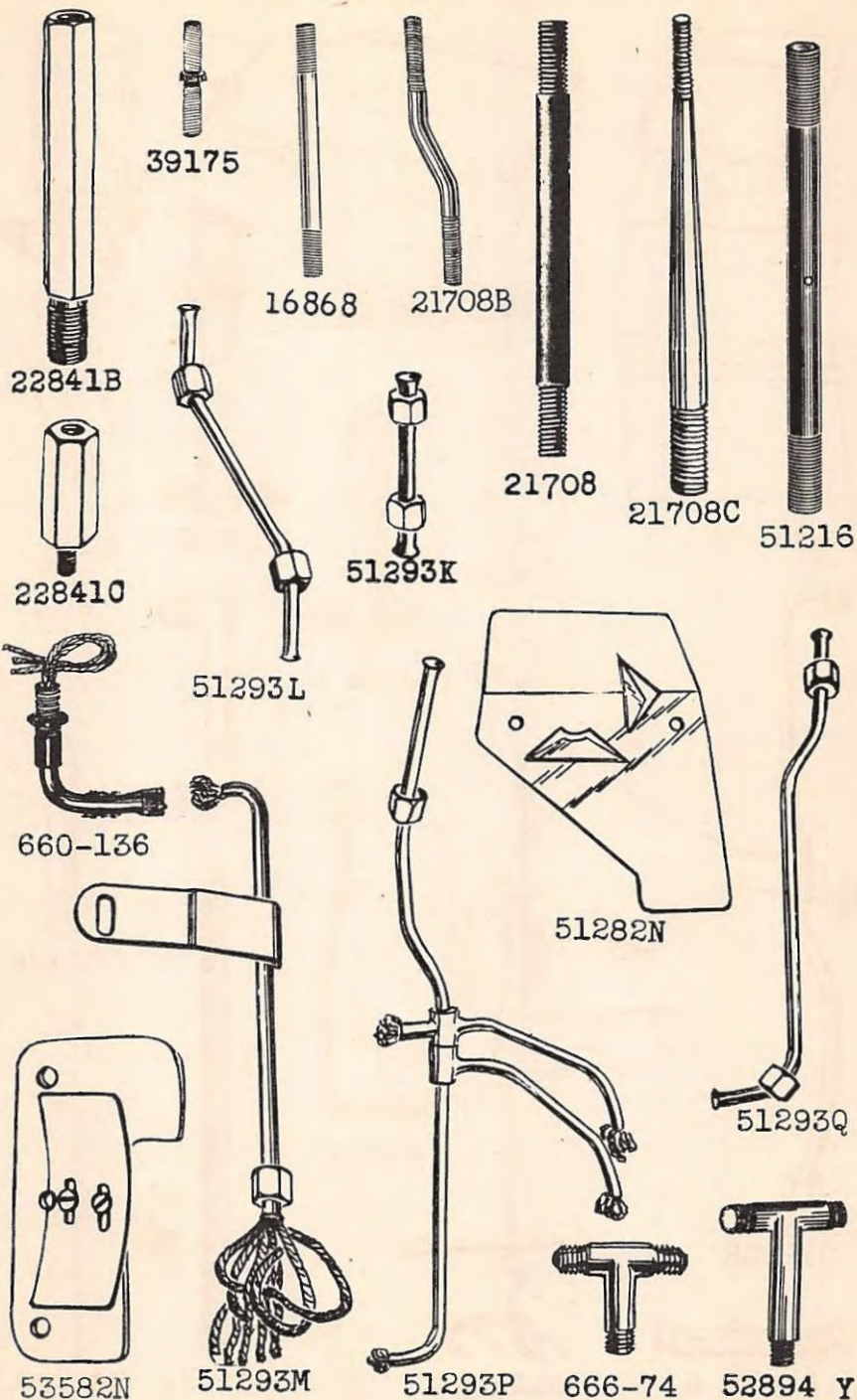
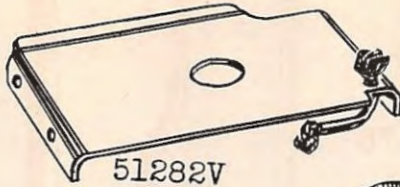

Plate 47 - One-half Size



51282F



51282V

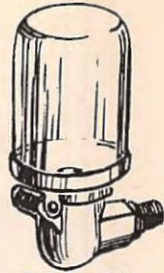

666-77

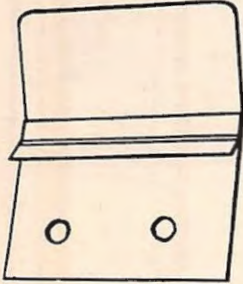

51782



52882 D



52795



52782H



35788B



52895 G



51743G

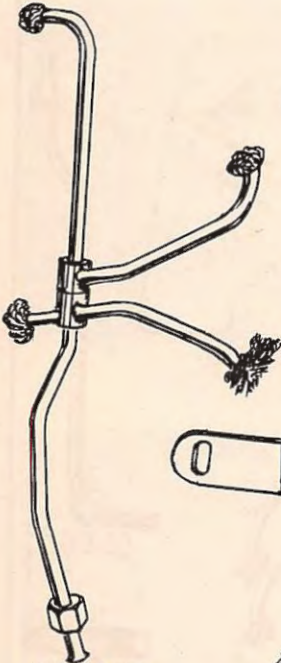

51293R

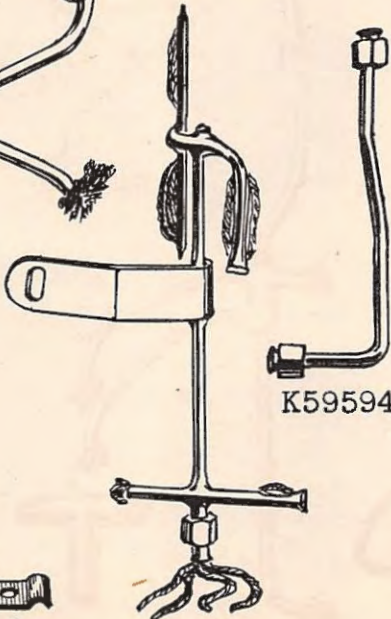

51293N



K59594



660-94



52894 J



51293A



666-29

Plate 48 - One-half Size

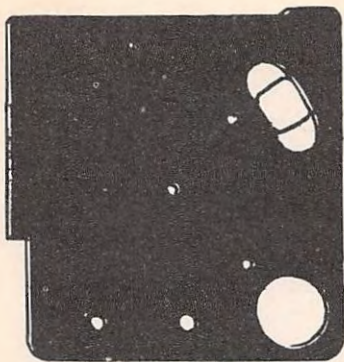

51281J  
Specify  
Minor  
Symbol

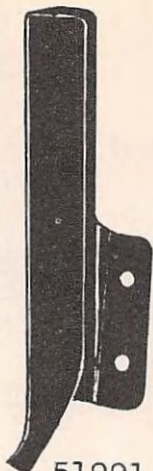

51991

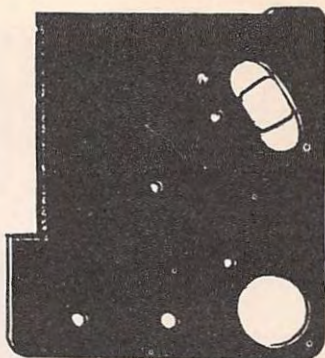

51281H  
Specify  
Minor  
Symbol

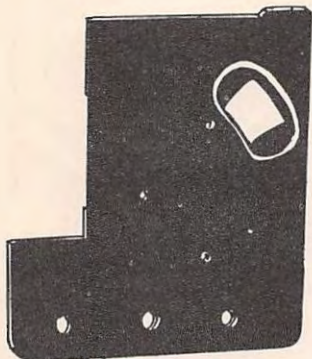

51281M-155

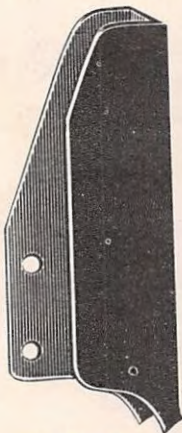

51291



K59923



51282B



51282T



53582H

Plate 49 - One-half Size



51282

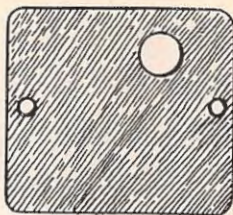

51282 H



52882 B

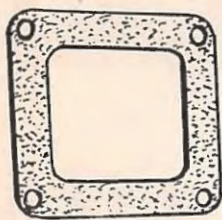

51282U



51775A



51202



52802A



51202 A



51281G



51281F



K59488



21104 E



52864E



43294D



660-81



21355



21104 C



Plate 50 - One-half Size

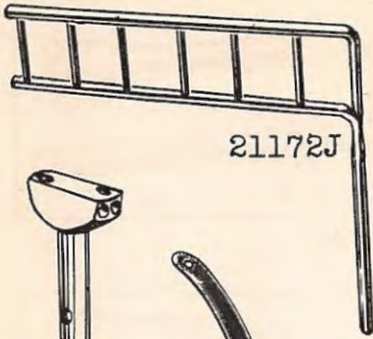

21172J



21172K



23279D



21145



9271



118B



21388



21388R



21388N



21693K



21693T



21693G



21693D



21693F



423

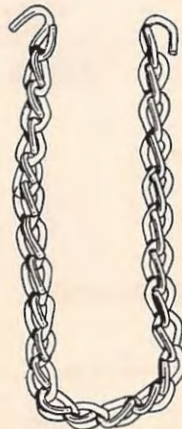

421 C  
SPECIFY  
LENGTH



421

Plate 51 - One-half Size

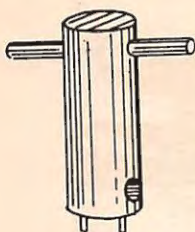

21388Z

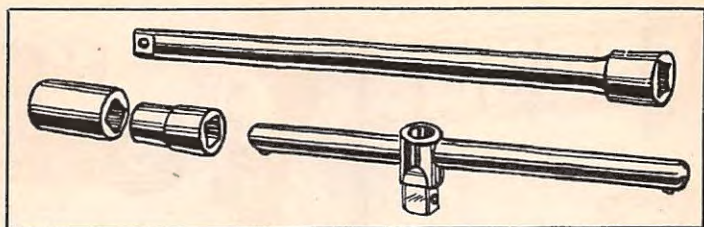

21388AE

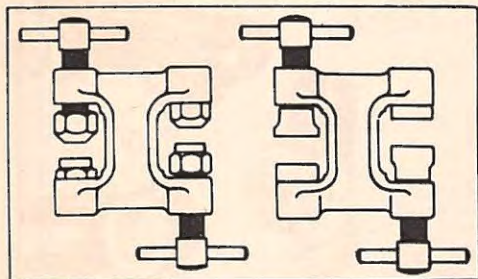

21227HH

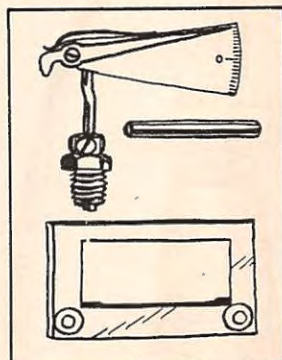

21227R

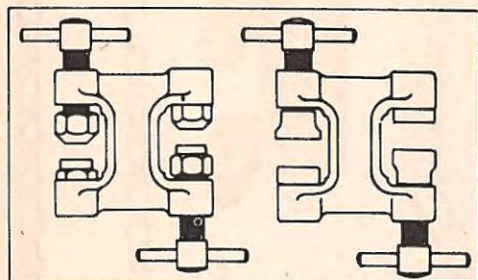

21227HK



116



21207

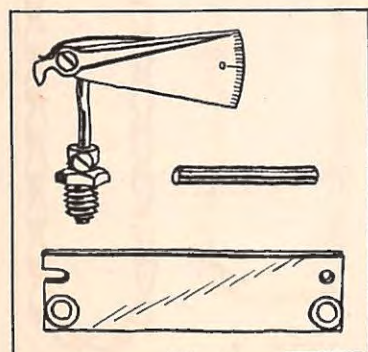

21227AC

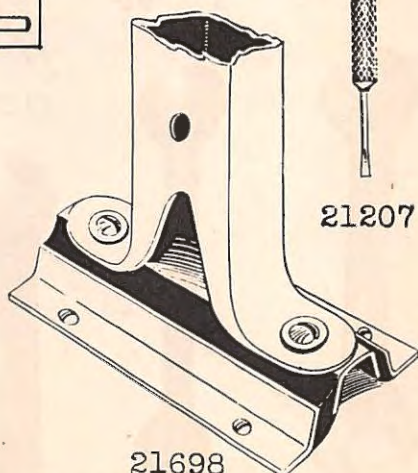

21698  
Specify Length

Plate 52 - One-fourth Size

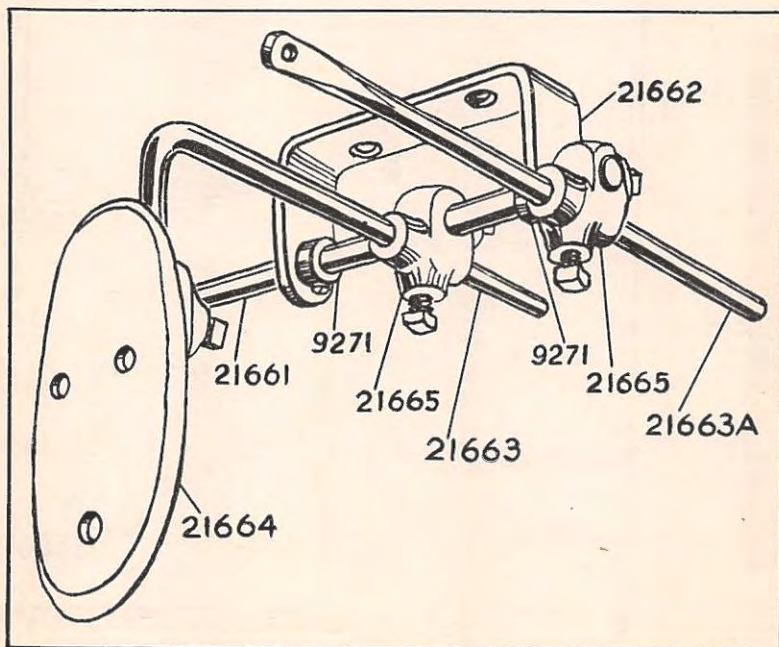

21660A

Plate 53 - One-fourth Size



29402



422

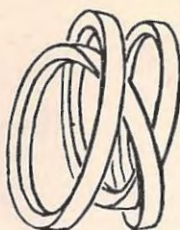

21262H

Specify Length



666-16



43294A



51294A



23439C



21104B  
Specify  
Length

100 B



21172N



23293N

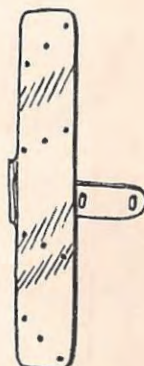

51491B-4



21172M

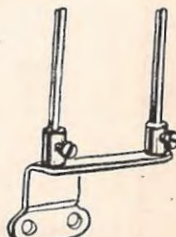

23439B



23324R

Plate 54 - One-fourth Size

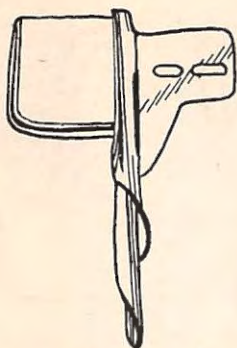

23360F-1/2

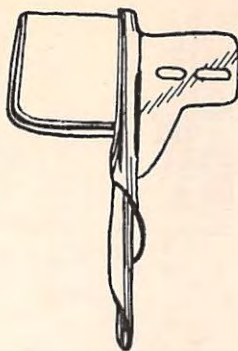

K49640

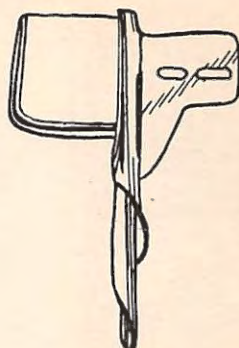

K49746

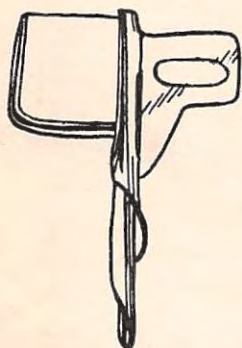

K59882

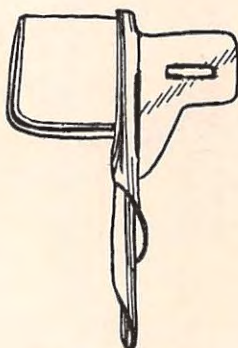

K40881

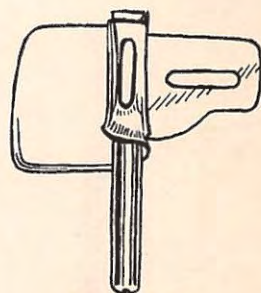

23168Q

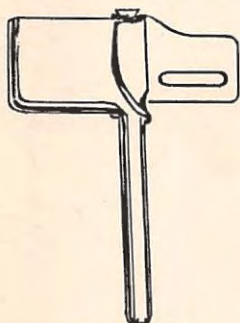

23168R

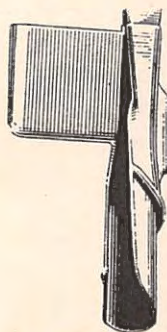

23406B-7/8



23435  
Specify Gauge



K59825



23360C-1 1/2

Plate 55 - One-fourth Size

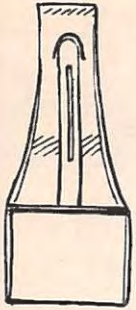

23401J-56



23401K  
Specify  
Gauge

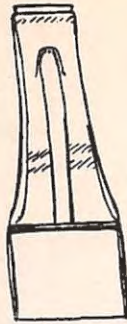

K58357

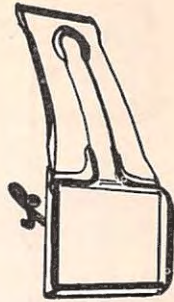

K53135

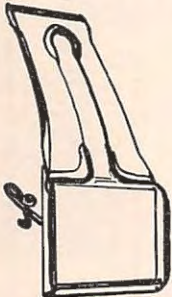

K53133

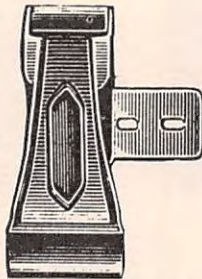

23293 P-96

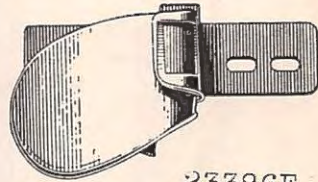

23386E  
Specify  
Width of Hem

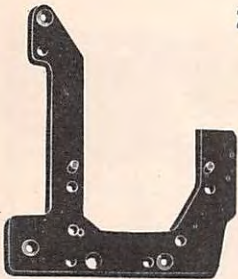

51480

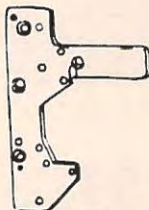

52830

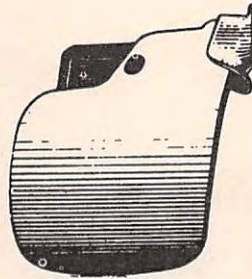

23325T-120



23406A-5/8



51280A



51280G



K60059

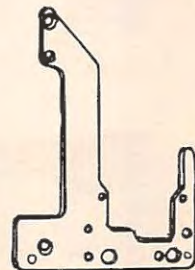

51780A

Plate 56 - One-fourth Size

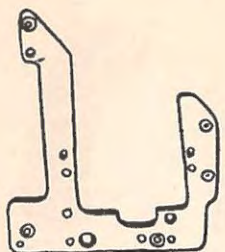

51280B

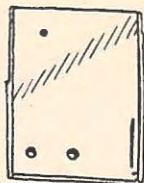

51402



52894 G

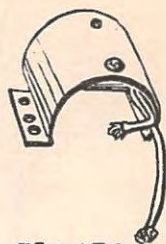

51443G



51281  
Specify  
Minor  
Symbol

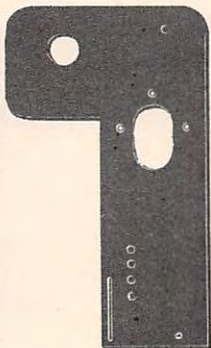

51281C-226

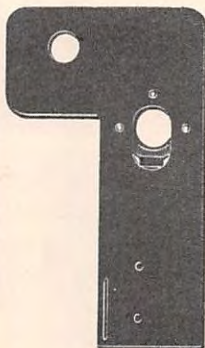

51281 E-226



K54654



52864B



51401C

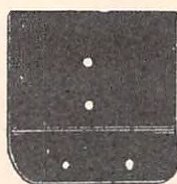

51482A



51282Q



51282E



51282R



51290 N



51290P



51282 J

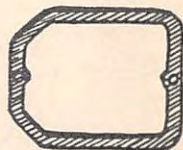

52882E

Plate 57 - One-fourth Size

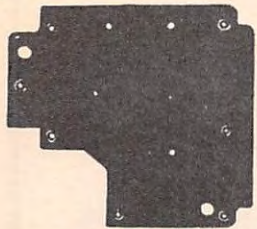

51282L

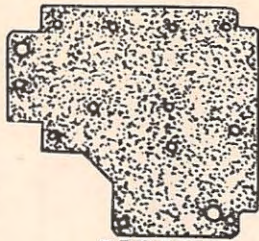

51282M



21375AH



51282S



51190D



51722



51222

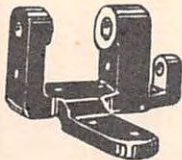

51239 J



7482P



29476 AD



29476 AE



29476 AF



29476AJ



29476AK



29476AY



Plate 58 - One-fourth Size



29348

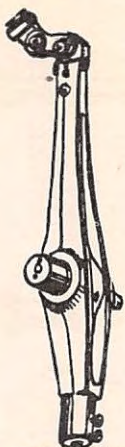

29348B



51215A



51215C



Y802



Y503  
Specify Size



Y500  
Specify Size



Y502  
Specify Size

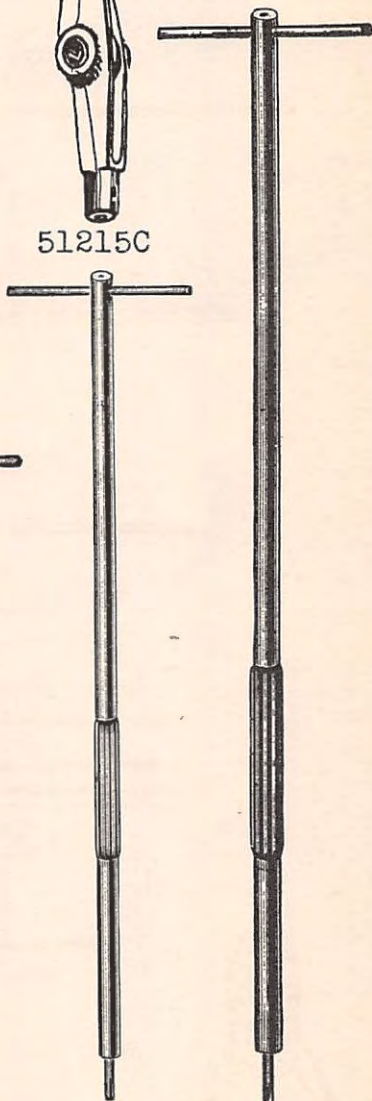

Y505  
Specify Size

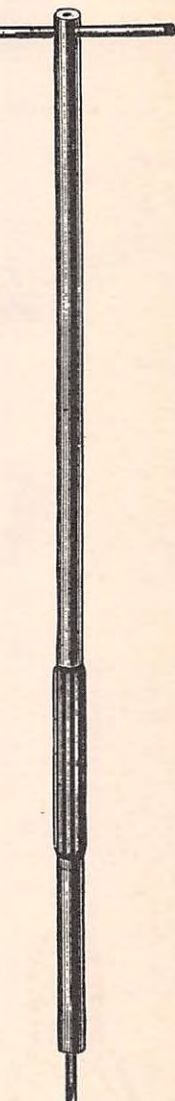

Y506  
Specify Size

Plate 59 - One-fourth Size



21204



21203



21205A



21202

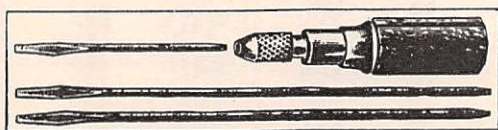

21208



21236



21201

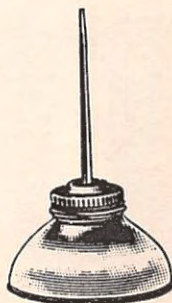

413

Plate 60 - One-eighth Size



51201C



51301B

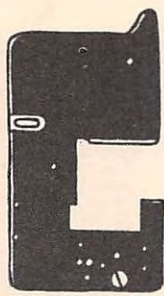

51401 D



51701G



51701P



K59922

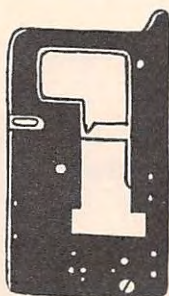

51201B



51201 E

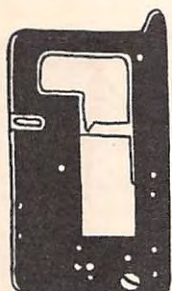

51301A



51401H

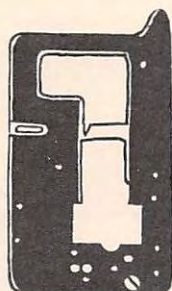

51701C



51701F

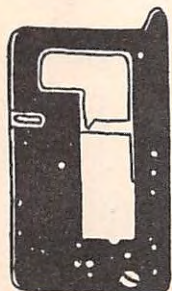

K55601



K55603

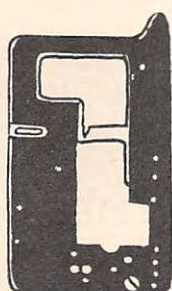

K55765



K59465

Plate 61 - One-eighth Size

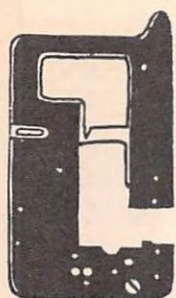

K59466



K59510



K59581



21680AK



51264



51482B



52885A



51285



51239 K



51743B



51494



51743F



51294 G



52883



51283E



51283



7486P



21697AA



21173A



69 S



21104G



21114 A



201A



21693B

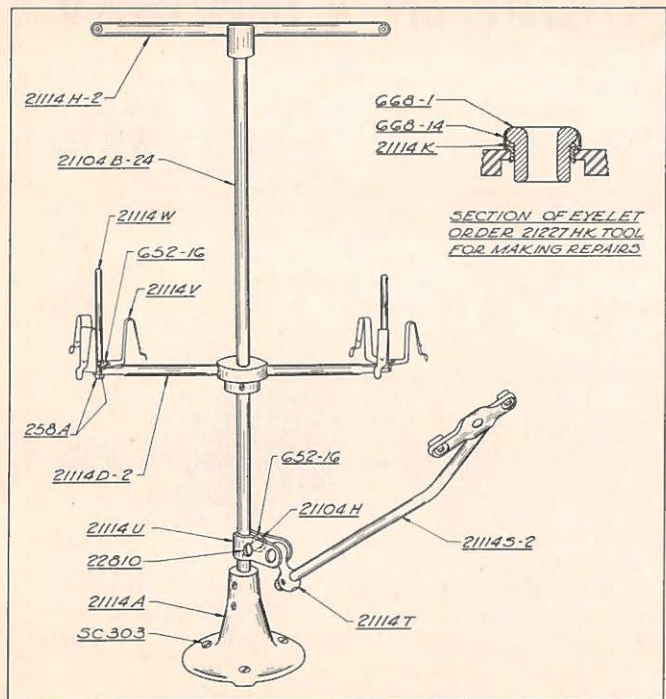

**ASSEMBLY No 2110IG-2**

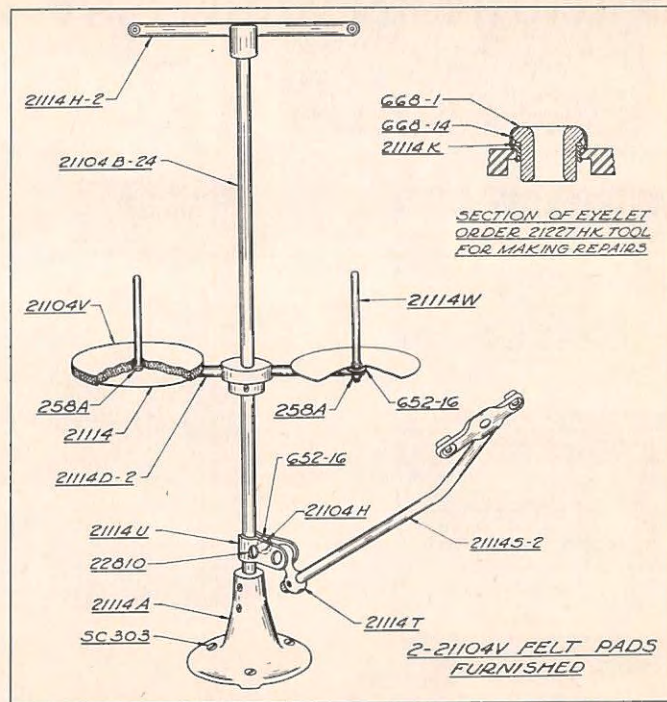

**ASSEMBLY No 2110IH-2**

Plate 62 - One-eighth Size

From the library of: Diamond Needle Corp

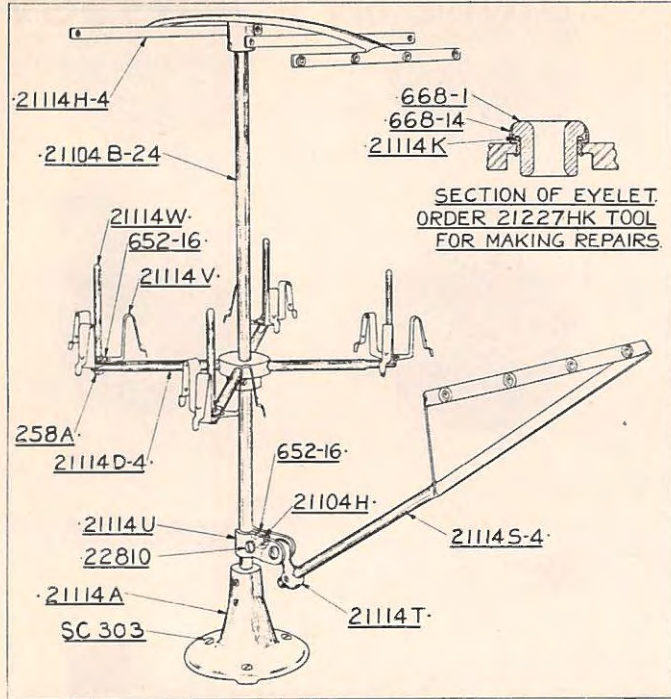

**ASSEMBLY N<sup>o</sup> 2110IG-4**

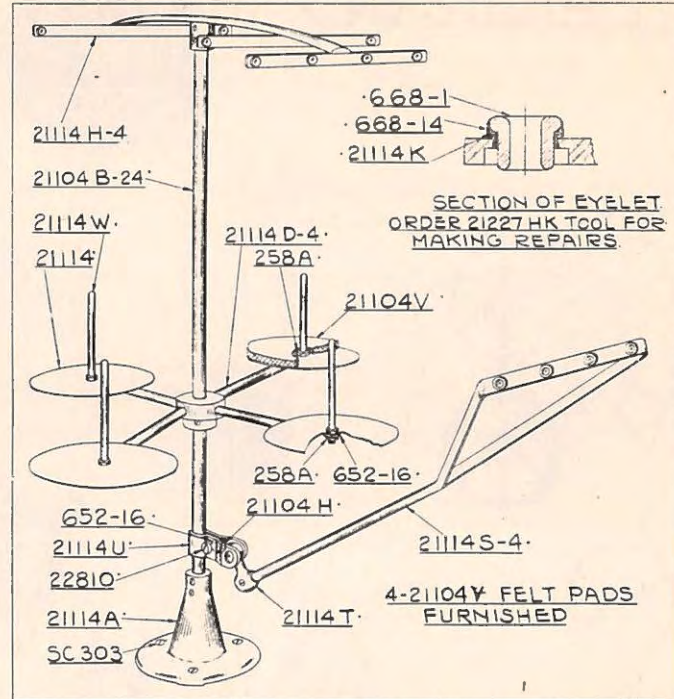

**ASSEMBLY N<sup>o</sup> 2110IH-4**

Plate 64 - One-eighth Size



21130 A-2

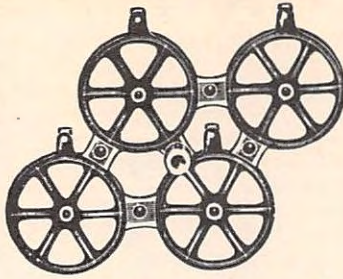

21130A-4



21104K



21104D



21104F



21169F

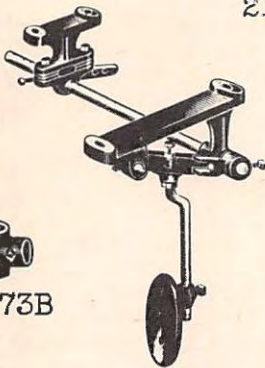

21173B



21385B



21157



21693A



21172E



21169E



01-19



21388X



21172F



21178

LIST OF PARTS

Symbol to Order By	The figures in the last column refer only to the plates illustrating the parts and are not to be used in ordering. Prices furnished on application.	Plate No.
T2	Pivot Stud, for collapsible folder connection on Styles 51700 F, 51700 M - - - - -	23
8	Feed Rocker Shaft, 5 3/16 inches long, for Styles 51200 U, 51200 V, 51400 AC, 51600 A	45
16	Feed Crank Link Ferrule- - - - -	26
18	Looper Connecting Rod Nut, right thread; also for Nos. 21708 B, 39175, 51241 D, 55241 N- -	25
OI-19	Pressure Pump Oil Can, 1 1/2 pints capacity- -	64
20	Feed Crank Stud Washer; also for No. 51758 - -	26
22 I	Feed Dog, for Styles 51200 H, 51200 S (screw No. 22528) - - - - -	7
24	Edge Guide, for Styles 51200 H, 51200 S, 51400 K, 51400 X, (thumbscrew No. 25)- - - - -	33
24 X	" " for Styles 51200 C, 51200 M (thumbscrew No. 25)- - - - -	33
25	Thumbscrew, for cloth plate edge guides- - -	24
25 B	Screw, for angular strip guides on Styles 51400 B, 51400 C, 51400 Q, 51400 R, 51700 C, 51700 D, 51700 J, 51700 K- - -	20
25 C	" 9/32 inch long, for cloth plate attach- ments - - - - -	21
25 S	" for folder clamp; also for Nos. 51482 A, 51782- - - - -	21
25 T	Thumbscrew, for folder swinging arm; also for Nos. 21172 F, 21172 L- - - - -	24
25 CC	Screw, for attaching folder clamp to folder; also for Nos. 8372, 23324 J- - - - -	20
28	Screw, for lap seam feller upper scroll; also for Nos. 51235 S, 51704, 52804, 52804 A- - -	20
28 C	Adjusting Screw, for stripper blade on Style 51600 A- - - - -	20
34	Nut, for right knee press interlocking lever on knee press assembly No. 21693 A; also for No. 21693 K- - - - -	25
36 G	Looper Connecting Rod Ball Stud Washer, for machines equipped with looper drive levers Nos. 51242 E, 51242 J, 51242 T, 51242 V- - -	26
J42 JK	Screw Pin, for presser roller axle support on Style 51400 G- - - - -	23
43	Feed Lift Eccentric, for styles in Classes 51400, 51700, Styles 51200 A, 51200 D, 51200 G, 51200 H, 51200 K, 51200 N, 51200 R, 51200 S, 51200 U, 51200 V, 51600 A; also looper avoid eccentric for styles in Classes 51400, 51700, Styles 51200 A, 51200 D, 51200 G, 51200 H, 51200 J, 51200 K, 51200 N, 51200 R, 51200 S, 51200 T, 51200 U, 51200 V, 51600 A; (spot screw No. 96) - - - - -	28



LIST OF PARTS

Symbol to Order By	The figures in the last column refer only to the plates illustrating the parts and are not to be used in ordering. Prices furnished on application.	Plate No.
43 C	Feed Lift Eccentric, for Styles 51200 B, 51200 C, 51200 J, 51200 L, 51200 M, 51200 T; also looper avoid eccentric for Styles 51200 B, 51200 C, 51200 L, 51200 M; (spot screw No. 96) - - - - -	28
50 J-16	Needle Stop Pin, for Styles 51400 A, 51400 E, 51400 H, 51400 P, 51400 T, 51400 V, 51400 AC; also for Nos. 16 and 18 gauge Style 51400 G - - - - -	29
50 J-40	Needle Stop Pin, for Styles 51400 B, 51400 C, 51400 D, 51400 F, 51400 J, 51400 K, 51400 M, 51400 N, 51400 Q, 51400 R, 51400 S, 51400 U, 51400 W, 51400 X, 51400 Y, 51400 AA, 51400 AB; also for No. 24 gauge Style 51400 G and Nos. 32 and 40 gauge Style 51700 L - - - - -	29
52 A	Frame Thread Eyelet, for styles in Class 51200, Style 51400 G; also for No. 52894 G (screw for attaching to frame, No. 98 A; screw for attaching to oil reservoir cover No. 87 U) - - - - -	18
54	Needle Lever Link - - - - -	41
56	Needle Clamp Nut, for Styles 51200 A, 51200 B, 51200 C, 51200 D, 51200 G, 51200 H, 51200 J, 51200 K, 51200 L, 51200 M, 51200 N, 51200 R, 51200 S, 51200 T - - - - -	25
57 WB	Needle Bar Thread Nipper Plate, for Style 51400 G - - - - -	17
57 WC	Needle Bar Thread Nipper Spring - - - - -	32
57 WD	Needle Bar Thread Nipper Stud; also for Nos. 9634, K57341- - - - -	22
HA61 D	Screw, for puller connecting rod guard on Style 51400 G - - - - -	21
64 A	Presser Spring Regulating Screw, for built-in puller on Style 51400 G - - - - -	24
64 B	Presser Spring Regulating Screw Lock Nut, for built-in puller on Style 51400 G - - - - -	25
65 A	Presser Foot, hinged bottom, for Styles 51200 H, 51200 S (clamp screw No. 91) - - - - -	10
69 S	Spool Pin, 4 inches long, for Style "C" thread stands - - - - -	61
69 FD	Screw, square head, cup point, 5/16 inch diameter, 18 threads per inch, 5/8 inch long, for thread stand seat; also for Nos. 21664, 21665, 21693 F, 21693 K - - - - -	22
73	Set Screw, for looper - - - - -	21
73 A	Screw, for presser foot strip guide on Styles 51700 G, 51700 H, 51700 N, 51700 P - - - - -	20
74	Clamp Screw, for looper drive lever No. 51242 V - - - - -	23

LIST OF PARTS

Symbol to Order By	The figures in the last column refer only to the plates illustrating the parts and are not to be used in ordering. Prices furnished on application.	Plate No.
75 A	Screw, for needle lever connecting rod bearing, lower; also for Nos. 29105 A, 29105 B - - - - -	23
77	Set Screw, for feed crank link pin, and upper needle lever link pin; also for Nos. 39135, 51236 A, 51420 C, 51720, 51720 D - - - - -	20
78	Set screw, for lower needle lever link pin - - - - -	20
79	Screw, for folder support swinging arm base on Styles 51200 U, 51200 V; also for Nos. 7475 Q, 51462 - - - - -	21
80	Screw, for countersunk head, for cloth plates; also for Nos. 51280 A, 51780 A, K60059 - - - - -	22
81	Spot Screw, for puller driving eccentrics; also for Nos. 29114 A, 29114 B, 41258 D, 51242 J, 51242 K, 51242 N, 51242 V - - - - -	20
86	Stud, for collapsible folder scrolls on Styles 51700 F, 51700 M; also for No. 7487 Q - - - - -	22
86 X	Presser Foot Hinge Stud, for Styles 51400 M, 51400 AA - - - - -	22
87	Screw, countersunk head, 1/4 inch long, for throat plates; also for No. 51777 L, K53849 - - - - -	22
87 A	Screw, countersunk head, for oil reservoir cover on Styles 51200 A, 51200 B, 51200 C, 51200 D, 51200 G, 51200 H, 51200 J, 51200 U, 51200 V, 51400 A, 51400 B, 51400 C, 51400 D, 51400 E, 51400 F, 51400 G, 51400 H, 51400 J, 51400 K, 51400 M, 51400 N, 51400 AC, 51600 A, 51700 C, 51700 D, 51700 E, 51700 F, 51700 G, 51700 H, 51700 T - - - - -	22
87 U	Screw, for oil reservoir cover thread eyelet; also for Nos. 41358, 51460, 51460 A, 51491, K55764 - - - - -	20
88	Set Screw, for looper rocker cone; also for Nos. 161, 1288, 21113 B, 21172 J, 21172 K, 23449, 51420 L, 51430 G, 51720 E, 51774 L, K53842, K53847, K54258 - - - - -	20
88 A	Set Screw, for needle bar; also for Nos. 51293 P, 51293 R - - - - -	21
88 B	Screw, for looper rocker shaft sleeves - - - - -	20
89	Spot Screw, for needle holders; also for Nos. 7486 P, 51461 A, 52836, 52883 G - - - - -	20
90	Screw, for crankshaft chamber cover; also for Nos. 8326, 8326 A, 8326 G, 15226 B, 23215 BC, 23322 AB, 23322 AC, 23438 B, 23439 A, 43281 K, 51170 F, 51270 B, 51759 A, 52864 E, K57284, K58649, K59088, K59499 - - - - -	21
91	Clamp Screw, 3/8 inch long, for presser feet - - - - -	21
91 A	Screw, for presser foot flexible toe on Styles 51700 C and 51700 J; also for Nos. 6235 and 51420 M, - - - - -	20
93	Screw, for pulley guard; also for Nos. 13153, 23229 M, K49290, 51244 B, 51494, 51743 B, 51743 F, 51774 P, K53845, K53855, K57261 - - - - -	21

LIST OF PARTS

Symbol to Order By	The figures in the last column refer only to the plates illustrating the parts and are not to be used in ordering. Prices furnished on application.	Plate No.
93 A	Screw, for looper thread guard; also for Nos. 2603 K, 23324 U, 23324 V, 23401 J, 23401 K, 51959-	21
94	Screw, for thread lead-in guide; also for Nos. 7459A, K51165, 51282 V, 51443 G, 52864 B, K53133, K53135	21
95	Set Screw, puller driving eccentrics; also for 41258 D, 51147, 51239 D, 53551, 53551 A	20
96	Spot Screw, for feed lift eccentric and looper avoid eccentric; also Nos. 51244, 51243 P, 51243 Q, 51343, 51423 B, 51443, 51723 A, 51744 A	20
96 A	Spot Screw, for puller feed roller on Style 51400 G	20
97	Screw, for needle lever and looper drive ball stud guide forks; also for Nos. 51293, 51420 M	21
97 A	Bearing Screw, for looper connecting rod ball joints; also for Nos. 29105 A, 29105 B, 51216 A	23
98	Set Screw, headless, 3/16 inch long, without pilot for needles; also for Nos. 482, 9271, 51135, 51235, 51243 P, 51243 Q, 51244, 51343, 51443, 51582	20
98 A	Screw, for frame thread eyelets; also for No. 23324 R	21
100 B	Thread Stand Wire, 16 inches long for Style "C" thread stands (set screw No. 22632 F-24)	53
107	Strip Tension Ferrule, for Styles 51400 D, 51400 G, 51400 S, 51700 D, 51700 K, 51700 T, 51700 U	18
108	Strip Tension Nut	25
109	Tension Disc, with contact surface 5/64 inch wide, for machines using needle thread the equivalent in size of No. 50 and smaller	18
109 B	Tension Disc, with contact surface 1/8 inch wide, for machines using needle thread the equivalent in size of No. 40 and larger	18
110-3	Tension Spring .040 inch diameter for tape reel axle; also for Nos. 21182 N, 21182 T	32
112	Throat Plate, for Styles 51200 H, 51200 S (screw No. 87)	1
116	Wrench, 9/32 inch opening for needle clamp nut	51
118 B	Thread Tweezers	50
V118	Tap, marked "X2", for plus size cloth plate screw No. 22521	30
134	Stud, for collapsible folder connection link on Styles 51700 F, 51700 M	22
136	Screw, for facing strip folder bracket on Styles 51400 B, 51400 D, 51400 Q, 51400 S, 51700 D, 51700 K, 51700 R	21

LIST OF PARTS

Symbol to Order By	The figures in the last column refer only to the plates illustrating the parts and are not to be used in ordering. Prices furnished on application.	Plate No.
158 B	Frame Looper Thread Eyelet, two holes, for Styles in Classes 51400, 51700, Style 51600 A (screw No. 98 A) - - - - -	18
161	Collar, for binding holder disc on Styles 51200 A, 51200 B, 51200 K, 51200 L, 51200 V (screw No. 88) - - - - -	26
166	Set Screw, hexagonal head, for feed bar on Styles 51200 U, 51400 G - - - - -	21
187 A	Screw, for crank shaft chamber cover oil drip plate on Styles 51200 K, 51200 L, 51200 M, 51200 N, 51200 R, 51200 S, 51200 T, 51400 P, 51400 Q, 51400 R, 51400 S, 51400 T, 51400 U, 51400 V, 51400 W, 51400 X, 51400 Y, 51400 AA, 51400 AB, 51700 J, 51700 K, 51700 L, 51700 M, 51700 N, 51700 P, 51700 Q, 51700 R, 51700 U; also for Nos. 8344, 11534, 23300 G, 23360 C, 23449 C, 51282 N, 52782 H, 53582 N, K60416, K60418 - - - - -	20
187 B	Screw, for needle holder thread guide; also for No. 1741 B - - - - -	20
188 D	Thumbscrew, for pin tension adjustable pin on Style 51200 V - - - - -	24
198 B-6	Presser Foot, for No. 26 gauge Styles 51400 J, 51400 W (clamp screw No. 91) - - - - -	11
201 A	Lower Tap Reel Support, Interlining Support, and Elastic Band Support, for Styles 51400 B, 51400 C, 51400 G, 51400 Q, 51400 R, 51400 S, 51700 C, 51700 D, 51700 E, 51700 J, 51700 K, 51700 L - - - - -	61
201 C	Thumbscrew, for lower tape reel axle - - - - -	24
223 C	Pivot Screw, for presser foot bottom on Style 51200 V - - - - -	22
226	Pivot Screw, for collapsible folder operating rod on Styles 51700 F, 51700 M - - - - -	22
236	Pivot Screw, for cloth plate swinging arm, on Styles 51200 U, 51200 V - - - - -	23
243	Cloth Plate End Cover Spring, on Styles 51200 U, 51200 V, 51400 G (screw No. 22711) - - - - -	38
258	Lock Nut, for differential feed regulating ratchet nut on Style 51200 V - - - - -	25
258 A	Nut for Looper Rocker Cone; also for Nos. 21114 W, 51134 G, 52887 N - - - - -	25
269	Looper Connecting Rod Nut, left thread; also for Nos. 21708 B, 21708 C, 51236 C - - - - -	25
318	Screw, for top roller feed clutch bracket on Styles 51200 U, 51200 V - - - - -	23
357	Screw, for cloth plate slide spring on Styles 51400 A, 51400 B, 51400 C, 51400 D, 51400 E, 51400 F, 51400 H, 51400 J, 51400 K, 51400 M, 51400 N, 51400 AC - - - - -	20

LIST OF PARTS

Symbol to Order By	The figures in the last column refer only to the plates illustrating the parts and are not to be used in ordering. Prices furnished on application.	Plate No.
358	Cloth Plate Sliding Cover Knob, for Styles 51200 U, 51200 V - - - - -	31
380	Spring, for cloth plate slide on Styles 51400 A, 51400 B, 51400 C, 51400 D, 51400 E, 51400 F, 51400 H, 51400 J, 51400 K, 51400 M, 51400 N, 51400 AC, (screw No. 257) - - - - -	31
402	Stud, for lifter lever link on Styles 51200 K, 51200 L, 51200 M, 51200 N, 51200 R, 51200 S, 51200 T, 51400 P, 51400 Q, 51400 R, 51400 S, 51400 T, 51400 U, 51400 V, 51400 W, 51400 X, 51400 Y, 51400 AA, 51400 AB, 51700 J, 51700 K, 51700 L, 51700 M, 51700 N, 51700 P, 51700 Q, 51700 R, 51700 U; also for No. 25324 R - - - - -	23
413	Oil Can, complete - - - - -	59
420	Presser Roller Lifter Lever Stud, length overall 1 43/64 inches for Style 51400 G - - - - -	24
420 C	Presser Roller Lifter Lever Stud, length overall 2 5/16 inches, for Style 51400 G (nut No. 11635 B) - - - - -	24
421	Lifter Lever Chain, 38 inches long - - - - -	50
421 C-34	Treadle Chain, 34 inches long - - - - -	50
422	Lifter Treadle (screw No. 22813) - - - - -	53
423	Lifter Treadle Base - - - - -	50
424	Lifter Treadle Pin (set screw No. 22813) - - - - -	45
426	Lifter Lever Spring, for Styles 51200 K, 51200 L, 51200 M, 51200 N, 51200 R, 51200 S, 51200 T, 51400 P, 51400 Q, 51400 R, 51400 S, 51400 T, 51400 U, 51400 V, 51400 W, 51400 X, 51400 Y, 51400 AA, 51400 AB, 51700 J, 51700 K, 51700 L, 51700 M, 51700 N, 51700 P, 51700 Q, 51700 R, 51700 U; also for No. 23260 C-1 1/2 - - - - -	32
482	Feed Rocker Shaft Collar (set screw No. 98) - - - - -	42
Y500-257	Expansion Reamer, for needle bar bearings, size .257 inch - - - - -	58
Y502-319	Expansion Reamer, for upper presser bar bearing, size .319 inch - - - - -	58
Y503-319	" " for lower presser bar bearing, size .319 inch - - - - -	58
Y505-407	" " for looper rocker and feed rocker shaft bearings, size .407 inch - - - - -	58
Y506-530	" " for main shaft bearings, size .530 inch - - - - -	58
538	Screw, for supporting feed dogs - - - - -	22
604	Screw, for intermediate gear guard on Styles 51700 E, 51700 L; also for No. 16241 - - - - -	20

LIST OF PARTS

Symbol to Order By	The figures in the last column refer only to the plates illustrating the parts and are not to be used in ordering. Prices furnished on application.	Plate No.
605 A	Screw, for differential feed gear yoke on Styles 51700 E, 51700 L; also for Nos. 7933, 8040, 9735, 16194, 23449 B, 51720 E, 51774 T- - - - -	20
627	Clamp Screw, for looper drive lever rocker on Styles 51200 K, 51200 L, 51200 M, 51200 N, 51200 R, 51200 S, 51200 T, 51400 P, 51400 Q, 51400 R, 51400 S, 51400 T, 51400 U, 51400 V, 51400 W, 51400 X, 51400 Y, 51400 AA, 51400 AB, 51700 J, 51700 K, 51700 L, 51700 M, 51700 N, 51700 P, 51700 Q, 51700 R, 51700 U- - - - -	22
650	Stove Bolt, flat head 1/4 x 1 1/4 inches- - - - -	25
650-28	Stove Bolt, 1/4 x 3 1/2 inches - - - - -	25
650-40	Stove Bolt, 1/4 x 5 inches - - - - -	25
650 A-16	Stove Bolt, flat head, 5/16 x 2 inches - - - - -	25
650 A-18	" " 5/16 x 2 1/4 inches- - - - -	25
650 A-20	" " 5/16 x 2 1/2 inches- - - - -	25
650 B-26	" " flat head, 3/8 x 3 1/4 inches, for table tops - - - - -	25
650 X-18	Carriage Bolt, 5/16 x 2 1/4 inches, for attaching "Electro Drives" - - - - -	24
650 X-22	Carriage Bolt, 5/16 x 2 3/4 inches, for attaching "Electro Drives" - - - - -	24
650 X-32	Carriage Bolt, 5/16 x 4 Inches, for attaching "Electro Drives" - - - - -	24
652-16	Washer, 1/4 inch - - - - -	26
652 C-9	Shake-Proof Lock Washer, for needle bar eyelet	26
660-75	Connection Sleeve Coupling, for Styles 51700 F, 51700 G, 51700 T- - - - -	19
660-81	Oil Drain Extension Pipe, for machines with Class 21700 Puller - - - - -	49
660-90	Felt Wiper, for looper drive eccentric connection on Styles 51200 A, 51200 B, 51200 C, 51200 D, 51200 G, 51200 H, 51200 J, 51200 U, 51200 V, 51400 A, 51400 B, 51400 C, 51400 D, 51400 E, 51400 F, 51400 G, 51400 H, 51400 J, 51400 K, 51400 M, 51400 N, 51400 AC, 51600 A, 51700 C, 51700 D, 51700 E, 51700 F, 51700 G, 51700 H, 51700 T- - - - -	19
660-92	Leather Washer, upper, for main shaft oil gauge on Styles 51200 A, 51200 B, 51200 C, 51200 D, 51200 G, 51200 H, 51200 J, 51200 U, 51200 V, 51400 A, 51400 B, 51400 C, 51400 D, 51400 E, 51400 F, 51400 G, 51400 H, 51400 J, 51400 K, 51400 M, 51400 N, 51400 AC, 51600 A, 51700 C, 51700 D, 51700 E, 51700 F, 51700 G, 51700 H, 51700 T; also for No. 39193- - - - -	26
660-93	Leather Washer, lower, 1/4 inch hole, for main shaft oil gauge; also for No. 39193- - - - -	26

LIST OF PARTS

Symbol to Order By	The figures in the last column refer only to the plates illustrating the parts and are not to be used in ordering. Prices furnished on application.	Plate No.
660-94	Glass Tube, for main shaft oil gauge- - - - -	47
660-95	Cap, for main shaft oil gauge - - - - -	19
660-127	Isolated Insulator Height Adjusting Felt Washers (set of 8) for "II" installations - - - - -	31
660-136	Feed Crank Link Oil Tube (nut No. 12987 A)- - -	46
666-13	Felt Wick, spring pressed, for main shaft bearings- - - - -	19
666-16	Oil Drain Reservoir, glass- - - - -	53
666-19	Felt Wick, for needle lever connecting rod bearing; also for No. 51236 - - - - -	19
666-28	Oil Cup, for needle lever stud (nut No. 12987 A)- - - - -	19
666-29	Felt Wick, for needle lever stud- - - - -	47
666-49	Glass Tube, for crank chamber oil reservoir sight gauge on Styles 51200 A, 51200 B, 51200 C, 51200 D, 51200 G, 51200 H, 51200 J, 51200 U, 51200 V, 51400 A, 51400 B, 51400 C, 51400 D, 51400 E, 51400 F, 51400 G, 51400 H, 51400 J, 51400 K, 51400 M, 51400 N, 51400 AC, 51600 A, 51700 C, 51700 D, 51700 E, 51700 F, 51700 G, 51700 H, 51700 T - - - - -	19
666-50	Oil Cup, press fit, for upper oil reservoir cover on Styles 51200 A, 51200 B, 51200 C, 51200 D, 51200 G, 51200 H, 51200 J, 51200 U, 51200 V, 51400 A, 51400 B, 51400 C, 51400 D, 51400 E, 51400 F, 51400 G, 51400 H, 51400 J, 51400 K, 51400 M, 51400 N, 51400 AC, 51600 A, 51700 C, 51700 D, 51700 E, 51700 F, 51700 G, 51700 H, 51700 T- - - - -	19
666-66	Oil Tube, for looper drive eccentric assemblies Nos. 29105 L, 29105 M - - - - -	19
666-74	Oil Line "T" Coupling, 1 inch long, for oil line to main shaft bearings on Style 51400 G-	46
666-77	Constant Level Oiler, for Styles 51200 K, 51200 L, 51200 M, 51200 N, 51200 R, 51200 S, 51200 T, 51400 P, 51400 Q, 51400 R, 51400 S, 51400 T, 51400 U, 51400 V, 51400 W, 51400 X, 51400 Y, 51400 AA, 51400 AB, 51700 J, 51700K, 51700 L, 51700 M, 51700 N, 51700 P, 51700 Q, 51700 R, 51700 U- - - - -	47
666-77 A	Top, for constant lever oiler - - - - -	-
666-77 B	Spring and Hinge Pin, for constant level oiler-	-
666-77 C	Gasket, for constant level oiler- - - - -	-
666-82	Oil Wick, for feed lift and looper avoid eccen- tric bearing on Styles 51200 K, 51200 L, 51200 M, 51200 N, 51200 R, 51200 S, 51200 T, 51400 P, 51400 Q, 51400 R, 51400 S, 51400 T, 51400 U, 51400 V, 51400 W, 51400 X, 51400 Y, 51400 AA, 51400 AB, 51400 AC, 51700 J, 51700 K, 51700 L, 51700 M, 51700 N, 51700 P, 51700 Q, 51700 R, 51700 U - - - - -	19

LIST OF PARTS

Symbol to Order By	The figures in the last column refer only to the plates illustrating the parts and are not to be used in ordering. Prices furnished on application.	Plate No.
667 D-16	Dowell Pin, 1 inch long, for puller frame on Style 51400 G- - - - -	29
668-1	Steel Insert, 17/64 inch long, for thread lead-in eyelet; also for Nos. 21114 H, 21114 S- - - - -	18
668-7	Steel Insert, 5/32 inch long, for tension thread eyelets - - - - -	18
668-12	Steel Insert Locking Ferrule, for tension thread eyelets - - - - -	18
668-13	Steel Insert Locking Ferrule, for take-up thread eyelets on Style 51400 G- - - - -	18
668-14	Steel Insert Locking Ferrule, for thread lead-in eyelet; also for Nos. 21114 H, 21114 S, - - - - -	18
719	Set Screw, for needle lever stud; also for Nos. 51250 B, 52835 U- - - - -	20
Y802	Taper Reamer, for needle lever link and feed crank link pins - - - - -	58
907	Differential Feed Regulating Stud Nut on Styles 51200 V, 51400 AC, 51600 A- - - - -	25
1248	Feed Crank Link Shim, leather- - - - -	19
1280	Looper Rocker Stud Nut, for Class 51700- - - - -	25
1286	Needle Lever Link Pin Assembly; also feed crank link pin assembly; one each Nos. 1286 A, 1286 B, 12964 C, 22560- - - - -	29
1286 A	Needle Lever Link Pin (set screw for upper link pin No. 77, clamp screw for upper link pin No. 22864, clamp screw nut No. 51250 C, set screw for lower link pin No. 78)- - - - -	29
1286 B	Needle Lever Link Pin Spring; also for No. HA1286 (screw No. 22560) - - - - -	32
HA1286	Presser Roller Fork Pin, for Style 51400 G (screw No. 22560 B)- - - - -	29
1287	Needle Bar Thread Nipper Assembly, for Style 51400 G; one each Nos. 57 WB, 57 WC, 57 WD, 88, 1288 - - - - -	18
1288	Needle Bar Thread Nipper Collar (screw No. 88)- - - - -	18
1332	Stop Screw Pin, for lifter lever on Styles 51200 K, 51200 L, 51200 M, 51200 N, 51200 R, 51200 S, 51200 T, 51400 P, 51400 Q, 51400 R, 51400 S, 51400 T, 51400 U, 51400 V, 51400 W, 51400 X, 51400 Y, 51400 AA, 51400 AB, 51700 J, 51700 K, 51700 L, 51700 M, 51700 N, 51700 P, 51700 Q, 51700 R, 51700 U - - - - -	23
1346	Strip Tension Post, for Styles 51400 D, 51400 G, 51400 S, 51700 D, 51700 K, 51700 T, 51700 U - - - - -	18



LIST OF PARTS

Symbol to Order By	The figures in the last column refer only to the plates illustrating the parts and are not to be used in ordering. Prices furnished on application.	Plate No.
1349 A-5	Tension Spring, conical, .040 inch diameter wire, for piping strip holder axle on Styles 51700 G, 51700 H, 51700 N, 51700 P- - - - -	32
1727 A	Presser Foot, for Styles 51200 D, 51200 N (clamp screw No. 91)- - - - -	10
1740	Presser Foot Yielding Section Plunger Pin, for Nos. 64, 72 and 80 gauge Styles 51700 E, 51700 L - - - - -	29
1741 B	Presser Foot Chain Cutting Knife, for Styles 51200 D, 51200 N (screw No.187 B)	14
2603 K	Edge Guide, for Styles 51200 D, 51200 N (screw No. 187 B) (attaching screw No. 93 A, roller No. 16675, roller pin No. 16676, roller arm spring No. 14775 A, throw-out lever screw No. 22772)- - - - -	35
4761	Looper Connecting Rod, 2 1/16 inches long for Nos. 112 and 128 gauge Styles in Class 51700 (nut, right thread, No. 18 nut, left thread, No. 269)- - - - -	30
5650	Main Feed Dog Holder, for Style 51200 V (screw No. 93)- - - - -	17
6042 A	Cloth Plate Cover Spring Washer, for Styles 51200 M, 51200 R, 51200 S, 51200 T, 51400 P, 51400 Q, 51400 R, 51400 S, 51400 T, 51400 U, 51400 V, 51400 W, 51400 X, 51400 Y, 51400 AA, 51400 AB, 51700 J, 51700 K, Nos. 32 and 40 gauge Style 51700 L, Styles 51700 N, 51700 P, 51700 Q, 51700 R; also for No. 51134 G - - - - -	26
6405 M	Feed Dog, for Styles 51200 B, 51200 L - -	8
6405 U	" " for Styles 51200 J, 51200 T - -	8
6405 W	" " for Styles 51200 C, 51200 M - -	8
6420 W	Feed Dog Screw No. 22528 Presser Foot, for Styles 51200 B, 51200 C, 51200 L, 51200 M (clamp screw No. 91, adjusting screw No. 22840 A, adjusting screw nut No. 51430 F)- - - - -	10
6424 W	Throat Plate, for Styles 51200 C, 51200 M	1
6428 L	" " for Styles 51200 J, 51200 T	1
K6805	Throat Plate Screw No. 87 Folder, upper, for gathering and stitching flounce to body of petticoats on No. 8 gauge Style 51600 A, 3/16 inch fold (screw No. 22561)- - - - -	33
K6806	Folder, lower, for turning edge of flounce on No. 8 gauge Style 51600 A, 3/16 inch fold (screw No. 25 C) - - - - -	33
7005 A-4 1/2	Feed Dog, for No. 16 gauge, Styles 51400 H, 51400 V (screw No. 22528)- - -	7
7005 A-6	Feed Dog, for No. 18 gauge, Styles 51400 H, 51400 V (screw No. 22528) - - -	7

LIST OF PARTS

Symbol to Order By	The figures in the last column refer only to the plates illustrating the parts and are not to be used in ordering. Prices furnished on application.	Plate No.
7018 E-5	Needle Holder, for No. 18 gauge Styles 51400 G, 51400 H, 51400 V - - - - -	17
7018 E-5 1/2	Needle Holder, for No. 24 gauge Style 51400 G- - - - -	17
7018 E-6	Needle Holder, for No. 26 gauge Styles 51400 J, 51400 W - - - - -	17
	Needle Holder Spot Screw No. 89 Needle Set Screw No. 98	
7020 B-4 1/2	Presser Foot, for No. 16 gauge Styles 51400 H, 51400 V - - - - -	11
7020 B-5	Presser Foot, for No. 18 gauge Style 51400 H, 51400 V - - - - -	11
	Presser Foot Clamp Screw No. 91	
7024 C-4 1/2	Throat Plate, for No. 16 gauge Styles 51400 H, 51400 V - - - - -	1
7024 C-5	" " for No. 18 gauge Styles 51400 H, 51400 V - - - - -	1
	Throat Plate Screw No. 87	
7040-6	Thread Guide, detachable, for needle holders on No. 18 gauge Styles 51400 G, 51400 H, 51400 V, No. 24 gauge Style 51400 G, No. 26 gauge Styles 51400 J, 51400 W- - - - -	17
7040-48	Thread Guide, detachable, for needle holders on Nos. 56 and 64 gauge styles in Class 51700 - - - - -	17
7040-61	Thread Guide, detachable, for needle holders on Nos. 72, 80, and 88 gauge styles in Class 51700- - - - -	17
	Thread Guide Screw No. 187 B	
7403 P	Supplemental Edge Guide, for Style 51400 G (screw No. 25 C) - - - - -	35
7405 B-6	Feed Dog, for No. 26 gauge Styles 51400 J, 51400 W - - - - -	8
7405 U-4 1/2	Feed Dog, for No. 16 gauge Style 51400 G -	7
7405 AF-5 1/2	Feed Dog, for No. 24 gauge Style 51400 G -	8
7405 AG-5	Feed Dog, for No. 18 gauge Style 51400 G -	8
	Feed Dog Screw No. 22528	
7420 AG-4 1/2	Presser Foot, for No. 16 gauge Style 51400 G- - - - -	11
7420 AG-5	Presser Foot, for No. 18 gauge - - - - -	11
7420 AG-5 1/2	Presser Foot, for No. 24 gauge - - - - -	11
	Presser Foot Clamp Screw No. 91	
7424 B-6	Throat Plate, for No. 26 gauge Styles 51400 J, 51400 W - - - - -	1
7424 AF-5 1/2	Throat Plate, for No. 24 gauge Style 51400 G- - - - -	2
7424 AG-5	Throat Plate, for No. 18 gauge Style 51400 G- - - - -	2
	Throat Plate Screw No. 87	

LIST OF PARTS

Symbol to Order By	The figures in the last column refer only to the plates illustrating the parts and are not to be used in ordering. Prices furnished on application.	Plate No.
7459 A	Take-up Thread Eyelet Spring, for Style 51400 G (screw No. 94) - - - - -	31
7475 Q	Puller Feed Clutch Flange, for Style 51400 G (screw No. 79) - - - - -	42
7476 P	Lower Puller Roller Shaft, for Style 51400 G - - - - -	45
7479 P	Lower Puller Roller Shaft Bushing, 63/64 inch long, for Style 51400 G - - - - -	26
7481 P	Presser Roller Axle Support, for Style 51400 G (stop pin No. J42 JK) - - - - -	43
7482 P	Presser Roller Hand Lifter Lever, for Style 51400 G (stud No. 420, nut No. 12982, set screw No. 92201) - - - - -	57
7485 P	Puller Connecting Rod Guard, for Style 51400 G (set screw No. HA61 D, Attaching screw No. 22517) - - - - -	43
7486 P	Presser Roller Lifter Lever, for Style 51400 G (screw No. 89, stud 420 C, nut No. 11635 B) - - - - -	61
7486 PA	Presser Roller Lifter Lever Angle Plate, for Style 51400 G (screw No. 22542) - - - - -	31
7487 Q	Presser Spring, for puller lifter lever on Style 51400 G (Stud No. 86) - - - - -	43
7489 P	Presser Roller Axle Support Guide Pin, for Style 51400 G - - - - -	45
7490 P	Puller Feed Roller, for Style 51400 G (spot screw No. 96 A, set screw No. 22597) - - - - -	43
7491 P	Puller Presser Roller, for Style 51400 G - - - - -	43
7528 H-4 1/2	Throat Plate, for No. 16 gauge Style 51400 G (screw No. 87) - - - - -	2
7933-48	Needle Stop Plate, for Nos. 56 and 64 gauge styles in Class 51700 - - - - -	17
7933-61	Needle Stop Plate, for Nos. 72, 80, and 88 gauge styles in Class 51700 - - - - -	17
7947	Needle Stop Plate Screw No. 605 A	
8040	Feed Crank Link Nut; also for No. 51245 Presser Foot Yielding Section Spring, for Nos. 64, 72, and 80 gauge Styles 51700 E, 51700 L, No. 128 gauge Styles 51700 G, 51700 H, 51700 N, 51700 P (attaching screw No. 605 adjusting screw No. 605 A) - - - - -	25
8118-64	Needle Holder, for No. 64 gauge styles in Class 51700 (spot screw No. 89, needle set screw No. 98) - - - - -	32
8305 L	Main Feed Dog, for No. 16 gauge Style 51600 A - - - - -	17
8305 N	" " " for No. 12 gauge Style 51600 A - - - - -	7
8305 S	" " " for No. 10 gauge Style 51600 A - - - - -	7
	Main Feed Dog Screw No. 22593	7

LIST OF PARTS

Symbol to Order By	The figures in the last column refer only to the plates illustrating the parts and are not to be used in ordering. Prices furnished on application.	Plate No.
8324 L-2	Throat Plate, for No. 8 gauge Style	
	51600 A - - - - -	2
8324 L-4	" " for No. 12 gauge - - - - -	2
8324 L-4 1/2	" " for No. 16 gauge Style	
	51600 A - - - - -	2
8326	Throat Plate Screw No. 87	
	Differential Feed Dog, for No. 16 gauge	
	Style 51600 A - - -	7
8326 A	" " " for No. 12 gauge	
	Style 51600 A - - -	7
8326 G	" " " for No. 10 gauge	
	Style 51600 A - - -	6
	Differential Feed Dog Screw No. 90	
8328 C-3	Throat Plate, for No. 10 gauge Style	
	51600 A (screw No. 87) - - - - -	2
8344	Stripper Blade, for Style 51600 A	
	(clamp screw No. 187 A, adjusting screw	
	No. 28 C) - - - - -	31
8372	Differential Feed Index Adjustable Stop,	
	for Styles 51400 AC, 51600 A (screw No.	
	25 CC, washer No. 8372 A) - - - - -	28
8372 A	Looper Drive Ball Joint Locking Stud	
	Washer; also for Nos. 8372, 23448,	
	51785, K53854, K54264 - - - - -	26
9255	Facing Strip Folder Washer, for Styles	
	51400 B, 51400 D, 51400 Q, 51400 S,	
	51700 D, 51700 K, 51700 R; also for No.	
	23436, K57370 - - - - -	26
9271	Knee Press Shaft Collar (screw No. 98) - -	50
9420 C-2	Presser Foot, for No. 8 gauge Style	
	51600 A - - - - -	10
9420 C-3	" " for No. 10 gauge - - - - -	10
9420 C-4	" " for No. 12 gauge - - - - -	10
9420 C-4 1/2	" " for No. 16 gauge - - - - -	10
	Presser Foot Clamp Screw No. 91	
9634	Presser Foot Yielding Bottom Spring, for	
	Styles 51200 G, 51200 R (screw No.	
	57 WD) - - - - -	32
9634 A	Presser Foot Yielding Bottom Spring pin,	
	for Styles 51200 G, 51200 R - - - - -	14
9663	Attaching Screw, for differential feed	
	regulating screw support bracket on	
	Style 51200 V - - - - -	23
9705	Feed Dog, for Styles 51200 G, 51200 R	
	(screw No. 22528) - - - - -	8
9720	Presser Foot, for Styles 51200 G, 51200 R	
	(clamp screw No. 91, yielding bottom	
	spring stud No. 57 WD, yielding bottom	
	spring No. 9634, yielding bottom spring	
	pin No. 9634 A, yielding section No.	
	9733, detachable toe No. 9735, detach-	
	able toe screw No. 605 A) - - - - -	10

LIST OF PARTS

Symbol to Order By	The figures in the last column refer only to the plates illustrating the parts and are not to be used in ordering. Prices furnished on application.	Plate No.
9724	Throat Plate, for Styles 51200 G, 51200 R (screw No. 87) - - - - -	1
9733	Presser Foot Yielding Section, for Styles 51200 G, 51200 R - - - - -	13
9735	Presser Foot Detachable Toe, for Styles 51200 G, 51200 R, (screw No. 605 A) - - - - -	15
9937	Lock Nut, for differential feed control lever, front, on Styles 51200 V, 51400 AC, 51600 A; also for No. 51235 N - - - - -	25
11534	Presser Foot Yielding Section Spring, for Styles 51200 J, 51200 T, (Support screw No. 187 A, attaching screw No. 605) - - - - -	32
11635 B	Nut, for presser roller lifter lever stud on Style 51400 G - - - - -	25
11638 M	Nut, for main shaft oil gauge on Styles 51200 A, 51200 B, 51200 C, 51200 D, 51200 G, 51200 H, 51200 J, 51200 U, 51200 V, 51400 A, 51400 B, 51400 C, 51400 D, 51400 E, 51400 F, 51400 G, 51400 H, 51400 J, 51400 K, 51400 M, 51400 N, 51400 AC, 51600 A, 51700 C, 51700 D, 51700 E, 51700 F, 51700 G, 51700 H, 51700 T -	25
12538	Looper Drive Lever Ball Stud Nut - - - - -	25
12934 A	Differential Feed Control Link Nut, for Styles 51200 V, 51400 AC, 51600 A; also for No. 52835 D - - - - -	25
12957 E	Spring Washer, for binder bracket on Styles 51200 B, 51200 L; also for No. 23449 A - - - - -	26
12964 C	Needle Lever Link Pin Ball - - - - -	19
12982	Lock Nut, for presser roller hand lifter lever regulating stud on Style 51400 G; also for No. K57272 - - - - -	25
12986 B	Pivot Stud, for collapsible folder scroll on Styles 51700 F, 51700 M - - - - -	20
12987 A	Nut, for needle lever stud oil cup; also for No. 660-136 - - - - -	25
12988 A	Plug Screw, for opening in top of bed on Styles 51200 A, 51200 B, 51200 C, 51200 D, 51200 G, 51200 H, 51200 J, 51400 A, 51400 B, 51400 C, 51400 D, 51400 E, 51400 F, 51400 H, 51400 J, 51400 K, 51400 M, 51400 N, 51700 C, 51700 D, 51700 E, 51700 F, 51700 G, 51700 H, 51700 T -	21
12993 A	Screw, for knee press interlocking arm stop on knee press assembly No. 21693 A; also for No. 21693 K - - - - -	22
13153	Main Feed Dog Holder, for Styles 51400 AC, 51600 A (screw No. 93) - - - - -	17
14077	Looper Rocker Ball Stud Nut, for styles in Class 51700 - - - - -	25

LIST OF PARTS

Symbol to Order By	The figures in the last column refer only to the plates illustrating the parts and are not to be used in ordering. Prices furnished on application.	Plate No.
14090	Looper Thread Tension Spring, for styles in Class 51700, Styles 51400 A, 51400 B, 51400 C, 51400 D, 51400 E, 51400 F, 51400 H, 51400 J, 51400 K, 51400 M, 51400 N, 51400 P, 51400 Q, 51400 R, 51400 S, 51400 T, 51400 U, 51400 V, 51400 W, 51400 X, 51400 Y, 51400 AA, 51400 AB, 51400 AC, 51600 A - - - - -	32
14775 A	Edge Guide Roller Arm Spring, for Styles 51200 D, 51200 N - - - - -	32
14786 A	Differential Feed Roll Yoke Support Pin, for Styles 51700 E, 51700 L - - - - -	29
15105 B	Main Feed Dog, for No. 8 gauge Style 51600 A (screw No. 22593) - - - - -	7
15226 B	Differential Feed Dog, for No. 8 gauge Style 51600 (screw No. 90) - - - - -	7
15430 C	Needle Lever Connecting Rod Nut, left thread; also for Nos. 21708, 21708 C - - - - -	25
15430 D	Needle Lever Connecting Rod Nut, right thread; also for Nos. 21693 J, 21708 - - - - -	25
15438 D	Differential Feed Intermediate Gear Stud, for Styles 51700 E, 51700 L (nut No. 43443 Q) - - - - -	22
15465 F	Looper Rocker Cone (screw No. 88, nut No. 258 A) - - - - -	28
15872 D	Pivot Stud, for top roller feed support on Styles 51200 U, 51200 V - - - - -	22
15872 F	Lifter Lever Spring, for Styles 51200 U, 51200 V, 51400 AC, 51600 A, 51700 T - - - - -	32
16152-56	Needle Holder, for No. 56 gauge styles in Class 51700 - - - - -	17
16152-72	Needle Holder, for No. 72 gauge - - - - -	17
16152-80	" " for No. 80 gauge - - - - -	17
16152-88	" " for No. 88 gauge - - - - -	17
16152-96	" " for No. 96 gauge - - - - -	17
16152-128	" " for No. 128 gauge - - - - -	17
	Needle Holder Spot Screw No. 89	
	Needle Set Screw No. 98	
16164	Tension Post Ferrule, for strip tension on Styles 51400 D, 51400 G, 51400 S, 51700 D, 51700 K, 51700 T, 51700 U - - - - -	26
16182	Needle Stop Plate, for No. 96 gauge styles in Class 51700 - - - - -	39
16182 C	" " " for No. 128 gauge styles in Class 51700 - - - - -	39
	Needle Stop Plate screw No. 605	
16194	Presser Yielding Section Spring, for Styles 51400 M, 51400 AA, 51700 F, 51700 G, 51700 H, Nos. 32 and 40 gauge Style 51700 L, Styles 51700 M, 51700 N, 51700 P, 51700 T, 51700 U (attaching screw No. 605, adjusting screw No. 605 A) - - - - -	32

LIST OF PARTS

Symbol to Order By	The figures in the last column refer only to the plates illustrating the parts and are not to be used in ordering. Prices furnished on application.	Plate No.
16194 B	Presser Foot Strip Guide, for Styles 51700 G, 51700 H, 51700 N, 51700 P (screw No. 73 A)	15
16241	Spring, for tilting right section of presser foot on Styles 51700 F, 51700 M, 51700 T, 51700 U (screw No. 604) - - - - -	32
16241 A	Spring, for tilting left section of presser foot on Styles 51700 F, 51700 M, 51700 T, 51700 U (screw No. 605) - - - - -	32
16505-88	Feed Dog, for No. 88 gauge Styles 51700 F, 51700 M - - - - -	9
16505-96	Feed Dog, for No. 96 gauge Styles 51700 T, 51700 U - - - - -	9
16524 B-88	Feed Dog Screw No. 22528 Throat Plate, for No. 88 gauge Styles 51700 F, 51700 M - - - - -	2
16524 B-96	Throat Plate, for No. 96 gauge Styles 51700 T, 51700 U - - - - -	2
16527 B-88	Throat Plate Screw No. 87 Presser Foot, for No. 88 gauge Styles 51700 F, 51700 M (set screw No. 22570, yielding section spring No. 16194, yielding section spring attaching screw No. 605, yielding section spring adjusting screw No. 605 A, right section tilting spring No. 16241, right section tilting spring screw No. 604, left section tilting spring No. 16241 A, left section tilting spring screw No. 605) - - - - -	12
16675	Edge Guide Roller, for Styles 51700 D, 51700 N - - - - -	26
16676	Edge Guide Roller Pin, for Styles 51700 D, 51700 N - - - - -	29
16868	Looper Connecting Rod, for No. 56 gauge styles in Class 51700 (nut, right thread, No. 18, nut, left thread, No. 269 - - - - -	46
21101 G-2	Thread Stand Assembly, Style G, for use with two cones; one each Nos. 21114 D-2, 21104 B-24, 21104 H, 21114 A, 21114 H-2, 21114 S-2, 21114 T, 22810; two each Nos. 21114 U, 21114 W; three No. 652-16; four No. 258 A; six No. 21114 V - - - - -	62
21101 G-4	Thread Stand Assembly, Style G for use with three and four cones; one each Nos. 21114 D-4, 21104 B-24, 21104 H, 21114 A, 21114 H-4, 21114 S-4, 21114 T, 22810; two No. 21114 U; four No. 21114 W; five No. 652-16; eight No. 258 A; twelve No. 21114 V - - - - -	63

LIST OF PARTS

Symbol to Order By	The figures in the last column refer only to the plates illustrating the parts and are not to be used in ordering. Prices furnished on application.	Plate No.
21101 H-2	Thread Stand Assembly, Style "H", for use with two spools; one each Nos. 21114 D-2, 21104 B-24, 21104 H, 21114 A, 21114 H-2, 21114 S-2, 21114 T, 22810, two each Nos. 21104 V, 21114, 21114 U, 21114 W, three No. 652-16, four No. 258 A - - - - -	62
21101 H-4	Thread Stand Assembly, Style "H", for use with three and four spools; one each Nos. 21114 D-4, 21104 B-24, 21104 H, 21114 A, 21114 H-4, 21114 S-4, 21114 T, 22810: two No. 21114 U; four each Nos. 21104 V, 21114, 21114 W; five No. 652-16; eight No. 258 A -	63
21104 B-2	Piping Cord Stand Rod, 2 inches long, for Styles 51700 G, 51700 H, 51700 N, 51700 P -	53
21104 B-11	Thread Stand Rod, 11 inches long, for Style "C" thread stands; also upper tape reel support rod and piping cord stand rod - - -	53
21104 B-14	Upper Tape Reel Support Rod, 14 inches long, for Styles 51700 G, 51700 H, 51700 N, 51700 P - - - - -	53
21104 B-20	Upper Tape Reel Support Rod, 20 inches long, for styles in Class 51700 - - - - -	53
21104 B-24	Thread Stand Rod, 24 inches long, for Styles "G" and "H" thread stands (set screw No. 22591) - - - - -	53
21104 C	Piping Cord Stand Connection, for Styles 51700 G, 51700 H, 51700 N, 51700 P (screw No. 22509) - - - - -	49
21104 D	Piping Cord Spool Seat, for Styles 51700 G, 51700 H, 51700 N, 51700 P - - - - -	64
21104 E	Piping Cord Spool Seat Connection, for Styles 51700 G, 51700 H, 51700 N, 51700 P - - - - -	49
21104 F	Piping Cord Spool Seat Pad, for Styles 51700 G, 51700 H, 51700 N, 51700 P - - - - -	64
21104 G	Piping Cord Spool Pin, for Styles 51700 G, 51700 H, 51700 N, 51700 P - - - - -	61
21104 H	Piping Cord Spool Pin Nut, for Styles 51700 G, 51700 H, 51700 N, 51700 P; also for No. 21114 U - - - - -	25
21104 K	Piping Cord Guide Wire, for Styles 51700 G, 51700 H, 51700 N, 51700 P (screw No. 22632 F-24) - - - - -	64
21104 V	Felt Pad, 5 1/4 inches diameter, for spool seat disc on Style "H" thread stand - - -	63
21105 J	Piping Cord Stand Cord Guide, for Styles 51700 G, 51700 H, 51700 N, 51700 P - - - -	18
21113 A	Thread Stand Wire Extension, 6 inches long, on Style "C" thread stands (set screw No. 22632 F-24) - - - - -	45
21113 B	Thread Stand Wire Coupling on Style "C" thread stands (screw No. 88) - - - - -	27



## LIST OF PARTS

Symbol to Order By	The figures in the last column refer only to the plates illustrating the parts and are not to be used in ordering. Prices furnished on application.	Plate No.
21114	Spool Disc Seat, for Style "H" thread stand	63
21114 A	Thread Stand Base; also upper tape reel support base (set screw No. 22591)- - -	61
21114 D-2	Seat, for two cones on Style "G" and "H" thread stands - - - - -	62
21114 D-4	Seat, for four cones on Styles "G" and "H" thread stands - - - - -	63
	Seat Screws No. 22591 A	
21114 H-2	Eyelet Support, for two cones on Style "G" and "H" thread stands - - - - -	62
21114 H-4	Eyelet Support, for four cones on Styles "G" and "H" thread stands - - - - -	63
	Eyelet Support Screws No. 22591 A -	
21114 K	Insert Gasket, for eyelet support on Styles "G" and "H" thread stands - - - - -	63
21114 S-2	Lead Eyelet, adjustable, for two cones on Styles "G" and "H" thread stands (insert No. 668-1, insert locking ferrule No. 668-14, insert gasket No. 21114 K)- - -	62
21114 S-4	Lead Eyelet, adjustable, for four cones on Styles "G" and "H" thread stands- - - - -	63
21114 T	Lead Eyelet Socket Ball, for Styles "G" and "H" thread stands (screw No. 22591) - - -	63
21114 U	Lead Eyelet Ball Split Socket, half section for Styles "G" and "H" thread stands (clamp screw No. 22810, nut No. 21104 H, washer No. 652-16)- - - - -	63
21114 V	Cone Holder Spring, for Style "G" thread stand - - - - -	63
21114 W	Spool Pin, for Styles "G" and "H" thread stands (nut No. 258 A)- - - - -	63
21130 A-2	Thread Stand Seat, two spools, on Style "C" thread stands - - - - -	64
21130 A-4	Thread Stand Seat, four spools, on Style "C" thread stands - - - - -	64
21145	Cone, wood, for thread stands- - - - -	50
21157	Upper Tape Reel Disc, 8 inches diameter - -	64
21169 E	Binding holder disc - - - - -	64
21169 F	Binding Holder Base - - - - -	64
21172 E	Piping Strip Holder Disc, right, for Styles 51700 G, 51700 H, 51700 N, 51700 P- - - -	64
21172 F	Piping Strip Holder Disc, left, for Styles 51700 G, 51700 H, 51700 N, 51700 P (thumbscrew No. 25 T)- - - - -	64
21172 J	Piping Strip Guide and Tension, for Styles 51700 G, 51700 H, 51700 N, 51700 P (set screw No. 88) - - - - -	50
21172 K	Piping Strip Guide and Tension Support, for Styles 51700 G, 51700 H, 51700 N, 51700 P (set screw No. 88)- - - - -	50

LIST OF PARTS

Symbol to Order By	The figures in the last column refer only to the plates illustrating the parts and are not to be used in ordering. Prices furnished on application.	Plate No.
21172 L	Piping Strip Disc Tension Spring Hub, for Styles 51700 G, 51700 H, 51700 N, 51700 P (thumbscrew No. 25 T) - - - - -	30
21172 M	Piping Strip Disc Supporting Rod Holder, for Styles 51700 G, 51700 H, 51700 N, 51700 P -	53
21172 N	Piping Strip Holder Disc Axle, for Styles 51700 G, 51700 H, 51700 N, 51700 P - - - - -	53
21173 A	Vertical Rod Support, for upper tape reel support (screw No. 22507) - - - - -	61
21173 B	Horizontal Rod Connection, for upper tape reel support (screw No. 22508) - - - - -	64
21178	Tape Reel Disc, 8 inches diameter, for Styles 51400 B, 51400 C, 51400 D, 51400 Q, 51400 R, 51400 S, 51700 C, 51700 D, 51700 E, 51700 G, 51700 H, 51700 J, 51700 K, 51700 L, 51700 N, 51700 P, 51700 R, 51700 S - - - - -	64
21182 K	Strip Tension Plate, outer, for Styles 51400 D, 51400 G, 51400 S, 51700 D, 51700 K, 51700 T, 51700 U - - - - -	38
21182 L	Strip Tension Plate, inner, for Styles 51400 D, 51400 S, 51700 D, 51700 K, 51700 T, 51700 U - - - - -	38
21182 N	Strip Tension Assembly, for Styles 51400 D, 51400 S, 51700 D, 51700 K, 51700 T, 51700 U; one each Nos. 21182 K, 21182 L, 21182 P; two each Nos. 107, 108, 110-3, 1346, 16164 - - - - -	38
21182 P	Strip Tension Base, for Styles 51400 D, 51400 G, 51400 S, 51700 D, 51700 K, 51700 T, 51700 U - - - - -	38
21182 T	Strip Tension Assembly, for Style 51400 G; one each Nos. 21182 K, 21182 P; two each Nos. 107, 108, 110-3, 1346, 16164 - - - - -	38
21201	Screw Driver, 9/64 inch round blade, length overall 7 5/8 inches - - - - -	59
21202	" " 7/32 inch round blade, length overall 11 1/4 inches - - - - -	59
21203	" " 13/64 inch round blade, length overall 15 1/2 inches - - - - -	59
21204	" " 9/32 inch round blade, length overall 15 inches - - - - -	59
21205 A	" " 3/8 inch round blade, length overall 14 inches - - - - -	59
21207	" " 7/64 inch round blade, length overall 2 1/2 inches - - - - -	51
21208	Screw Driver Set, three detachable blades - -	59
21210	Looper Collar, .040 inch thick - - - - -	26
21210 A	" " .020 inch thick - - - - -	26
21211	" " .054 inch thick - - - - -	26
21225-1/8	Looper Adjusting Gauge, 1/8 inch measurement	31

LIST OF PARTS

Symbol to Order By	The figures in the last column refer only to the plates illustrating the parts and are not to be used in ordering. Prices furnished on application.	Plate No.
21225-5/32	Looper Adjusting Gauge, 5/32 inch measurement-	31
21227 R	Gauge, for synchronizing looper and needle motions on machines with throat plates 2 1/4 inches long, component parts are shipped in leather case	51
21227 AC	Gauge, for synchronizing looper and needle motions on machines with throat plates 3 1/8 inches long, component parts are shipped in leather case	51
21227 HH	Eyelet Replacement Tool Set, for assembling 1/16 inch internal diameter eyelet No. 668-7 and ferrule No. 668-12 in tension thread eyelet assembly. Ferrule should always be replaced-	51
21227 HK	Insert Replacement Tool Set, for assembling 1/8 inch internal diameter inserts No. 668-1 and ferrules No. 668-14 in thread lead-in eyelet assembly; also for Nos. 21114 H-2, 21114 H-4, 21114 S-2, 21114 S-4. Ferrules should always be replaced-	51
21233 N	Connector, with BX cable for D.C. "Electro Drives"	—
21233 P	Connector, with BX cable for single and three phase A.C. "Electro Drives"	—
21233 X	Light Fixture Assembly, including bulb and blue lens, table mounting, for machines driven by "Electro Drive"	—
21233 Y	Light Fixture Assembly, including bulb and clear lens-	—
21233 Z	Light Fixture Assembly, including bulb, but without lens-	—
21236	Belt Plier, for 3/8 inch and smaller round belting	59
21260	Emery Cord, 3/64 inch diameter, grade No. 120, fifty yard spool-	—
21260 A	Emery Cord, 3/64 inch diameter, grade No. 150, fifty yard spool	—
21260 B	Emery Cord, 1/32 inch diameter, grade No. 180, fifty yard spool	—
21260 C	Emery Cord, .025 inch diameter, grade No. 200, fifty yard spool	—
21260 D	Emery Tape, 3/32 inch wide, grade No. 180, fifty yard spool-	—
21260 E	Emery Cord, .018 inch diameter, grade No. 200, fifty yard spool	—
21261	Leather Belt, flat, 1 inch wide, 63 inches long, includes belt fastener No. 21350-	—
21262	Leather Belt, round, 9/32 inch diameter, 44 inches long, includes wire belt hook No. 21351	—

LIST OF PARTS

Symbol to Order By	The figures in the last column refer only to the plates illustrating the parts and are not to be used in ordering. Prices furnished on application.	Plate No.
21262 H-340	"V" Belt, No. 2 size, 34 inches outside circumference- - - - -	53
21262 H-350	"V" Belt 35 inches outside circumference -	53
21262 H-370	" " 37 inches outside circumference -	53
21262 H-380	" " 38 inches outside circumference -	53
21300 C-5 3/4	Carriage Bolt, countersunk head, 3/8 x 5 3/4 inches, for table tops - - - - -	—
21350	Belt Fastener, malleable iron, for 1 inch flat belt- - - - -	31
21351	Belt Hook, wire, for 9/32 inch round belt-	31
21355	Chair Leg Extension, 4 inches long - - - -	49
21375 AH	Pulley Guard (screw No. 93)- - - - -	57
21385 B	Lower Tape Reel Axle, for Styles 51400 B, 51400 C, 51400 D, 51400 Q, 51400 R, 51400 S, 51700 C, 51700 D, 51700 E, 51700 J, 51700 K, 51700 L (thumbscrew No. 201 C) - - - - -	64
21388	Wrench, single end, 3/8 inch opening - - -	50
21388 N	" double end, 3/16 and 5/16 inch openings - - - - -	50
21388 R	" double end, 3/8 and 1/2 inch openings - - - - -	50
21388 X	" for main shaft bearing housing - - -	64
21388 Z	" for setting needle lever stud with respect to oil groove. Stud is set correctly when the pin hole nearest the periphery is up and a line drawn between the two pin holes is 45 degrees to the right of the ver- tical- - - - -	51
21388 AE	Socket Wrench Assembly, for 9/32 inch and 3/8 inch hexagonal nuts, for looper lever ball stud locking stud and tilting feed mechanism - - - - -	51
21394	Utility Grinder, including emery wheel, 5 inches diameter, 1/4 inch face, round belt drive, recommended speed 3000 R.P.M.- - - - -	—
21394 G	Emery Wheel, 5 inches diameter, 1/4 face, 3/8 inch hole, grade "M" emery 60-	—
21394 H	Emery Wheel, 5 inches diameter, 1/2 inch face, 3/8 inch hole, grade "M" emery 60 - - - - -	—
21394 K	Utility Grinder, including emery wheel, 5 inches diameter, 1/2 inch face, round belt drive, recommended speed 3000 R.P.M.- - - - -	—
21657-2	Tension Release Disc Separator, for styles in Class 51200, Style 51400 G- - -	39

LIST OF PARTS

Symbol to Order By	The figures in the last column refer only to the plates illustrating the parts and are not to be used in ordering. Prices furnished on application.	Plate No.
21657-4	Tension Release Disc Separator, for styles in Class 51700, Styles 51400 A, 51400 B, 51400 C, 51400 D, 51400 E, 51400 F, 51400 H, 51400 J, 51400 K, 51400 M, 51400 N, 51400 P, 51400 Q, 51400 R, 51400 S, 51400 T, 51400 U, 51400 V, 51400 W, 51400 X, 51400 Y, 51400 AA, 51400 AB, 51400 AC, 51600 A- - - - -	39
21657 A	Tension Release Rock Shaft, for Styles 51200 A, 51200 B, 51200 C, 51200 D, 51200 G, 51200 H, 51200 J, 51200 U, 51200 V, 51400 A, 51400 B, 51400 C, 51400 D, 51400 E, 51400 F, 51400 G, 51400 H, 51400 J, 51400 K, 51400 M, 51400 N, 51400 AC, 51600 A, 51700 C, 51700 D, 51700 E, 51700 F, 51700 G, 51700 H, 51700 T-	45
21657 B	Tension Release Rock Shaft Connection, clamp screw No. 22585- - - - -	31
21657 C	Tension Release Rock Shaft Lever (clamp screw No. 22596, stud No. 22594) - - - - -	39
21657 D	Tension Release Rock Shaft Lever Link, for Styles 51200 A, 51200 B, 51200 C, 51200 D, 51200 G, 51200 H, 51200 J, 51400 A, 51400 B, 51400 C, 51400 D, 51400 E, 51400 F, 51400 G, 51400 H, 51400 J, 51400 K, 51400 M, 51400 N, 51700 C, 51700 D, 51700 E, 51700 F, 51700 G, 51700 H, (stud No. 22515) - - - - -	39
21657 E	Cast-off Plate Support Washer- - - - -	26
21657 J	Tension Release Rock Shaft Connection Link, for Styles 51200 U, 51200 V, 51400 AC, 51600 A, 51700 T - - - - -	39
21657 L	Tension Release Rock Shaft, for Styles 51200 K, 51200 L, 51200 M, 51200 N, 51200 R, 51200 S, 51200 T, 51400 P, 51400 Q, 51400 U, 51400 S, 51400 T, 51400 U, 51400 V, 51400 W, 51400 X, 51400 Y, 51400 AA, 51400 AB, 51700 J, 51700 K, 51700 L, 51700 M, 51700 P, 51700 Q, 51700 R, 51700 U- - - - -	45
21657 M	Tension Release Rock Shaft Lever Link, for Styles 51200 K, 51200 L, 51200 M, 51200 N, 51200 R, 51200 S, 51200 T, 51400 P, 51400 Q, 51400 R, 51400 S, 51400 T, 51400 U, 51400 V, 51400 W, 51400 X, 51400 Y, 51400 AA, 51400 AB, 51700 J, 51700 K, 51700 L, 51700 M, 51700 N, 51700 P, 51700 Q, 51700 R, 51700 U - - - - -	39
21657 P	Tension Release Rock Shaft Bushing, for Styles 51200 K, 51200 L, 51200 M, 51200 N, 51200 R, 51200 S, 51200 T, 51400 P, 51400 Q, 51400 R, 51400 S, 51400 T, 51400 U, 51400 V, 51400 W, 51400 X, 51400 Y, 51400 AA, 51400 AB, 51700 J, 51700 K, 51700 L, 51700 M, 51700 N, 51700 P, 51700 Q, 51700 R, 51700 U- - - - -	45

LIST OF PARTS

Symbol to Order By	The figures in the last column refer only to the plates illustrating the parts and are not to be used in ordering. Prices furnished on application.	Plate No.
21660 A	Knee Press Assembly, for Style 51700 M; one each Nos. 21661, 21662, 21663, 21663 A, 21664; two each Nos. 98, 9271, 21665; five No. 69 FD- - - - -	52
21661	Knee Press Shaft, for assembly No. 21660 A - -	52
21662	" " Shaft Hanger, for assembly No. 21660 A - - - - -	52
21663	" " Plate Rod, for assembly No. 21660 A -	52
21663 A	" " Lever, for assembly No. 21660 A - -	52
21664	" " Plate, for assembly No. 21660 A (screw No. 69 FD) - - - - -	52
21665	" " Plate Rod Connection, for assembly No. 21660 A; also for No. 21663 A (screw No. 69 FD) - - - - -	52
21680 AK	Base Plate, for nonsubmerged and semisubmerged installations on six isolators - - - - -	61
21685	Knee Press Plate, for assembly No. 21693A- - -	52
21692	" " Chain, 18 1/2 inches long, for Style 51200 N - - - - -	52
21693 A	" " Assembly, for Style 51200 N; one each Nos. 15430 D, 21685, 21693 B, 21693 C, 21693 D, 21693 F, 21693 G, 21693 H, 21693 J, 21693 K, 21693 T, 22622; two each Nos. 34, 650-10, 12993 A; three No. 69 FD and four No. 28577- - - - -	64
21693 B	Knee Press Shaft, for assembly No. 21693 A - -	61
21693 C	" " Shaft Bracket, front, for assembly No. 21693 A - - - - -	52
21693 D	" " Shaft Bracket, rear, for assembly No. 21693 A (bolt No. 650-10, compensating washer No. 28577)- - -	50
21693 F	Knee Press Interlocking Forked Arm, for assembly No. 21693 A (set screw No. 69 FD) -	50
21693 G	Knee Press Interlocking Arm, with engaging pin, for assembly No. 21693 A (set screw No. 22622, stop screw No. 12993 A lock nut No. 34) - - - - -	50
21693 H	Knee Press Interlocking Arm Pivot Pin, 1 5/8 inches long, for assembly No. 21693 A- - - -	30
21693 J	Knee Press Plate Rod, for assembly No. 21693 A (lock nut No. 15430 D) - - - - -	52
21693 K	Knee Press Chain Arm, for assembly No. 21693 A (set screw No. 69 FD, stop screw No. 12993 A, lock nut No. 34)- - - - -	50
21693 T	Knee Press Shaft Hanger Spacing Block, for assembly No. 21693 A - - - - -	50
21697 AA	Belt Take-up and Hanger Assembly, for "V" belt installations- - - - -	61
21698-2	Vibration Insulator, two inches long, for tables - - - - -	51
21698-4	Vibration Insulator, four inches long- - - -	51
21698-5	" " five inches long- - - - -	51

LIST OF PARTS

Symbol to Order By	The figures in the last column refer only to the plates illustrating the parts and are not to be used in ordering. Prices furnished on application.	Plate No.
21698-6	Vibration Insulator, six inches long- - - - - NOTE: Special lengths will be furnished on request. Part of the table leg is shown in the illustration for clarity.	51
21701 A	Base Plate, for machines equipped with Class 21700 puller- - - - -	-
21708	Puller Driving Eccentric Connecting Rod, for Styles 51700 F, 51700 G, 51700 T (nut, left thread, No. 15430 C, nut, right thread, No. 15430 D)- - - - -	46
21708 B	Puller Driving Eccentric Connecting Rod, for Style 51400 G (nut, right thread, No. 18, nut, left thread No. 269) - - - - -	46
21708 C	Puller Driving Eccentric Connecting Rod Tube, for Styles 51700 M, 51700 N, 51700 U, (nut large, No. 15430 C, nut, small, No. 269)- - - - -	46
21723 C	Puller Presser Roller Axle, for Style 51400 G - - - - -	45
21724 A	" " " " Spring - - - - -	32
21725	" " " " " Screw - - - - -	24
22504	Screw, for guide leading strip to feed dog on Styles 51700 E, 51700 L - - - - -	23
22507	Set Screw, square head, cup point, 1/4 inch diameter, 20 threads per inch, 3/8 inch long for upper tape reel support vertical connection- - - - -	22
22508	Set screw, square head, cup point, 1/4 inch diameter, 20 threads per inch, 1/2 inch long, for upper tape reel post; also for No. 21173 B - - - - -	22
22509	Set Screw, square head, cup point, 5/16 inch diameter, 18 threads per inch, 1/2 inch long, for piping cord stand connection- - - - -	22
22513	Screw, for presser bar connection guide plate; also for No. K59503 - - - - -	21
22515	Stud, for tension release rock shaft lever link- - - - -	21
22516	Screw, for feed rocker segment slot plate on Styles 51200 V, 51400 AC, 51600 A - - - - -	21
22517	Screw, for puller connecting rod guard on Style 51400 G - - - - -	23
22519	Set Screw, hexagonal head, for needle lever ball stud on Styles 51200 A, 51200 B, 51200 C, 51200 D, 51200 G, 51200 H, 51200 J, 51200 U, 51200 V - - - - -	21
22519 C	Clamp Screw, for feed rocker arm- - - - -	21
22521	Screw, plus size for cloth plate (tap V118) - - - - -	22

LIST OF PARTS

Symbol to Order By	The figures in the last column refer only to the plates illustrating the parts and are not to be used in ordering. Prices furnished on application.	Plate No.
22524	Screw, countersunk head, for oil reservoir top cover on Styles 51200 K, 51200 L, 51200 M, 51200 N, 51200 R, 51200 S, 51200 T, 51400 P, 51400 Q, 51400 R, 51400 S, 51400 T, 51400 U, 51400 V, 51400 W, 51400 X, 51400 Y, 51400 AA, 51400 AB, 51700 J, 51700 K, 51700 L, 51700 M, 51700 N, 51700 P, 51700 Q, 51700 R, 51700 U - - - - -	22
22528	Screw, for feed dogs; also for Nos. 23229 P, 51243 B, 51457 A, 51757 A, 52857 B - - - - -	21
22532	Stripper Blade Adjusting Stud, for body folder on Styles 51700 E, 51700 L - - - - -	24
22539 A	Plug Screw, for looper drive lever shaft hole on Styles 51200 K, 51200 L, 51200 M, 51200 N, 51200 R, 51200 S, 51200 T, 51400 P, 51400 Q, 51400 R, 51400 S, 51400 T, 51400 U, 51400 V, 51400 W, 51400 X, 51400 Y, 51400 AA, 51400 AB, 51700 J, 51700 K, 51700 L, 51700 M, 51700 N, 51700 P, 51700 Q, 51700 R, 51700 U - - - - -	24
22539 C	Plug Screw, for bolt hole in cloth plates - - - - -	24
22542	Screw, for presser roller lifter lever angle plate on Style 51400 G - - - - -	21
22548	Screw, for facing folder on Styles 51200 V, 51400 B, 51400 D, 51400 Q, 51400 S, 51700 D, 51700 E, 51700 K, 51700 L, 51700 R, 51700 T, 51700 U; also for Nos. 23293 N, 23435, 23439 B, 23447 B - - - - -	21
22557	Screw, for collapsible folder lever on Styles 51700 F, 51700 M - - - - -	23
22559 A	Bearing Screw, lower, for Nos. 29105 L, 29105 M, 29105 P, 29105 Q - - - - -	23
22559 B	Bearing Screw, upper, for Nos. 29105 L, 29105 M, 29105 P, 29105 Q - - - - -	23
22559 C	Bearing Screw, for puller driving eccentric connection on Styles 51400 G, 51700 M, 51700 N, 51700 U; also for feed clutch driving eccentric connection on Styles 51200 U, 51200 V - - - - -	23
22560	Screw, for needle lever link pin - - - - -	20
22560 A	Set Screw, for roller feed clutch stationary lever locking pin on Styles 51200 U, 51200 V	20
22560 B	Set Screw, Headless, for feed bar; also for Nos. HA1286, 51462 B, 51751 - - - - -	20
22561	Screw, for upper folder on Style 51600 A; also for Nos. K58111, K60416, K60418 - - - - -	20
22562	Screw, for folder swinging arm latch on Styles 51200 U, 51200 V - - - - -	21
22565 C	Screw, for lower differential feed roll on Styles 51700 E, 51700 L - - - - -	20



LIST OF PARTS

Symbol to Order By	The figures in the last column refer only to the plates illustrating the parts and are not to be used in ordering. Prices furnished on application.	Plate No.
22566 A	Stud, for lifter lever on Styles 51200 K, 51200 L, 51200 M, 51200 N, 51200 R, 51200 S, 51200 T, 51400 P, 51400 Q, 51400 R, 51400 S, 51400 T, 51400 U, 51400 V, 51400 W, 51400 X, 51400 Y, 51400 AA, 51400 AB, 51700 J, 51700 K, 51700 L, 51700 M, 51700 N, 51700 P, 51700 Q, 51700 R, 51700 U - - - - -	24
22566 C	Stud, for lifter lever on Styles 51200 A, 51200 B, 51200 C, 51200 D, 51200 G, 51200 H, 51200 J, 51200 U, 51200 V, 51400 A, 51400 B, 51400 C, 51400 D, 51400 E, 51400 F, 51400 G, 51400 H, 51400 J, 51400 K, 51400 M, 51400 N, 51400 AC, 51600 A, 51700 C, 51700 D, 51700 E, 51700 F, 51700 G, 51700 H, 51700 T - - - - -	24
22567	Screw, for folder support bracket on Style 51200 V - - - - -	21
22569	" for feed crank link; also for No. 51245 - - - - -	23
22569 B	" for main shaft bearing housing - - - - -	21
22570	" fillister head for throat plates; also for Nos. 16527 B-88, K55764 - - - - -	21
22571 A	Plug Screw, for spring pressed felt wick on main shaft bearings; also for oil drain hole in crankshaft chamber - - - - -	20
22574	Screw, 21/32 inch long, for cloth plates; also for No. 52880 - - - - -	22
22580	Set Screw, for shielded disc take-up; also for Nos. 51239 E, 51239 G - - - - -	20
22581	Screw, for differential feed roll yoke support on Styles 51700 E, 51700 L - - - - -	21
22585	Clamp Screw, for tension release rock shaft connection; also for Nos. 23437 B, 52894 J - - - - -	21
22585 A	Screw, fillister head, for oil reservoir top cover on Styles 51200 K, 51200 L, 51200 M, 51200 N, 51200 R, 51200 S, 51200 T, 51400 P, 51400 Q, 51400 R, 51400 S, 51400 T, 51400 U, 51400 V, 51400 W, 51400 X, 51400 Y, 51400 AA, 51400 AB, 51700 J, 51700 K, 51700 L, 51700 M, 51700 N, 51700 P, 51700 Q, 51700 R, 51700 U - - - - -	22
22585 B	Screw, for needle rear guard - - - - -	22
22586	Plug Screw, for puller eccentric bearing on Styles 51400 G, 51700 M, 51700 N, 51700 U; also for Nos. 29114 A, 29114 B - - - - -	20
22586 B	Plug Screw, for center bearing lug on Style 51200 U - - - - -	20
22587	Screw, for puller drive eccentric bearing on Styles 51700 F, 51700 G, 51700 T - - - - -	23
22591	Set Screw, for thread stand rod; also for No. 21114 T - - - - -	20
22591 A	Set Screw, for thread stand cone seat; also for No. 21114 H - - - - -	20

LIST OF PARTS

Symbol to Order By	The figures in the last column refer only to the plates illustrating the parts and are not to be used in ordering. Prices furnished on application.	Plate No.
22595	Screw, for main feed dog on Styles 51200 V, 51400 AC, 51600 A; also for Nos. 23447 A, 23447 C, 39237 D- - - - -	22
22594	Stud, for tension release rock shaft lever- -	23
22596	Clamp Screw, for tension release rock shaft lever; also for No. 43294 A - - - - -	21
22597	Spot Screw, for pulley; also for Nos. 7490 P, 52835 U, 52835 W- - - - -	20
22597 A	Folder Clamp Screw, for Style 51200 V; also for Nos. 51221, 51242 A, 51242 B, 51321 A, 51321 B - - - - -	20
22622	Set Screw, for knee press interlocking arm on assembly No. 21693 A - - - - -	20
22632 F-24	Set Screw, flat head, cup point, 3/16 inch diameter, 3/8 inch long, 24 threads per inch, for thread stand wires; also for Nos. 21104 K, 21113 A- - - - -	22
22637 A	Screw, 1 1/2 inches long for fastening ma- chine to puller base plate on Styles 51700 F, 51700 G, 51700 M, 51700 N, 51700 T, 51700 U- - - - -	25
22637 B	Screw, 2 1/2 inches long for fastening machine to puller base plate on Styles 51700 F, 51700 G, 51700 M, 51700 N, 51700 T, 51700 U- - - - -	25
22637 D	Screw, 1 3/4 inches long for fastening machine to puller base plate on Styles 51700 F, 51700 G, 51700 M, 51700 N, 51700 T, 51700 U- - - - -	25
22704	Screw, for clutch roller spring on Styles 51200 U, 51200 V, 51400 G - - - - -	20
22711	Screw, for cloth plate end cover spring on Styles 51200 U, 51200 V, 51400 G; also for No. 51291 - - - - -	21
22716	Screw, for looper drive eccentric oil disc on looper drive eccentric assemblies Nos. 29105 L, 29105 M- - - - -	22
22716 A	Screw, for looper drive eccentric oil disc washer on looper drive eccentric assemblies Nos. 29105 L, 29105 M - - - - -	22
22726	Screw, for cloth plate cover spring on Styles 51200 M, 51200 R, 51200 S, 51200 T, 51400 P, 51400 Q, 51400 R, 51400 S, 51400 T, 51400 U, 51400 V, 51400 W, 51400 X, 51400 Y, 51400 AA, 51400 AB, 51700 J, 51700 K, 51700 N, 51700 P, 51700 Q, 51700 R, Nos. 32 and 40 gauge Style 51700 L- - - - -	22

LIST OF PARTS

Symbol to Order By	The figures in the last column refer only to the plates illustrating the parts and are not to be used in ordering. Prices furnished on application.	Plate No.
22726 A	Screw, for cloth plate cover spring on Styles 51200 A, 51200 B, 51200 C, 51200 D, 51200 G, 51200 H, 51200 J, 51200 K, 51200 L, 51200 N, 51400 B, 51400 C, 51400 D, 51400 F, 51400 G, 51400 H, 51400 J, 51400 M, 51400 N, 51600 A, 51700 C, 51700 D, 51700 E, 51700 F, 51700 G, 51700 H, 51700 M, 51700 T, 51700 U; also for Nos. 51777, K52851, K54262- - - - -	20
22730	Screw, for frame needle thread guide; also for Nos. 23406 A, 23406 B - - - - -	21
22733 A	Plug Screw, for needle thread take-up hole on Styles 51200 U, 51200 V - - - - -	21
22735	Pivot Stud, for binder bracket on Styles 51200 B, 51200 L; also for No. 23449 A - - - -	22
22743	Screw, for upper differential feed roll on Styles 51700 E, 51700 L; also for No. 29237 -	20
22747	Screw, for clutch disc on Styles 51200 U, 51200 V, 51400 G - - - - -	21
22752 B	Screw, for adjusting presser foot bottoms on Styles 51400 B, 51400 C, 51400 D, 51400 F, 51400 N, 51400 Q, 51400 R, 51400 S, 51400 U, 51400 AB, 51700 C, 51700 D, 51700 J, 51700 K, 51700 Q, 51700 R - - - - -	21
22753 B	Screw, for lifter lever link on Styles 51200 K, 51200 L, 51200 M, 51200 N, 51200 R, 51200 S, 51200 T, 51400 P, 51400 Q, 51400 R, 51400 S, 51400 T, 51400 U, 51400 V, 51400 W, 51400 X, 51400 Y, 51400 AA, 51400 AB, 51700 J, 51700 K, 51700 L, 51700 M, 51700 N, 51700 P, 51700 Q, 51700 R, 51700 U; also for Nos. 52835 D, 52835 G - - - - -	22
22764 A	Spot Screw, for parallel take-up on Style 51400 G - - - - -	20
22765	Clamp Screw, for presser foot on Style 51400 AC	21
22768	Screw, for needle bar and needle lever thread eyelets, also for Nos. 2603 K, 51236 B, 5235A -	20
22769	Screw, for crank chamber oil tube clamp on Styles 51200 A, 51200 B, 51200 C, 51200 D, 51200 G, 51200 H, 51200 J, 51200 U, 51200 V, 51400 A, 51400 B, 51400 C, 51400 D, 51400 E, 51400 F, 51400 G, 51400 H, 51400 J, 51400 K, 51400 M, 51400 N, 51400 AC, 51600 A, 51700 C, 51700 D, 51700 E, 51700 F, 51700 G, 51700 H, 51700 T - - - - -	22
22772	Screw, for edge guide throw-out lever on Styles 51200 D, 51200 N - - - - -	22
22773	Screw, for folder swinging arm on Styles 51400 B, 51400 C, 51400 Q, 51400 R, 51700 C, 51700 D, 51700 G, 51700 H, 51700 J, 51700 K, 51700 N, 51700 P, 51700 Q - - - - -	22

LIST OF PARTS

Symbol to Order By	The figures in the last column refer only to the plates illustrating the parts and are not to be used in ordering. Prices furnished on application.	Plate No.
22778	Screw, for lifter lever spring on Styles 51200 K, 51200 L, 51200 M, 51200 N, 51200 R, 51200 S, 51200 T, 51400 P, 51400 Q, 51400 R, 51400 S, 51400 T, 51400 U, 51400 V, 51400 W, 51400 X, 51400 Y, 51400 AA, 51400 AB, 51700 J, 51700 K, 51700 L, 51700 M, 51700 N, 51700 P, 51700 Q, 51700 R, 51700 U - - - - -	23
22788	Screw, for puller frame on Style 51400 G - - -	22
22794 B	" for parallel take-up flange on Style 51400 G - - - - -	23
22795	Stitch Regulating Screw - - - - -	24
22797	Stop Screw, for differential feed roll yolk support for Styles 51700 E, 51700 L - - - - -	22
22799	Hinge Screw, length overall 21/32 inch, diameter .177 inch, for presser foot bottom on Styles 51700 F, 51700 M, 51700 T, 51700 U -	23
22799 B	Hinge Screw, length overall 19/32 inch, diameter .088 inch, for presser foot bottoms on Styles 51200 J, 51200 T, 51400 A, 51400 E, 51400 K, 51400 P, 51400 T, 51400 X - - - - -	23
22799 D	Hinge Screw, length overall 49/64 inch, diameter .124 inch, for presser foot bottom on Styles 51400 B, 51400 C, 51400 D, 51400 F, 51400 N, 51400 Q, 51400 R, 51400 S, 51400 U, 51700 C, 51700 D, 51700 J, 51700 K, 51700 Q, 51700 R - - - - -	23
22799 E	Hinge Screw, length overall, 41/64 inch, diameter .088 inch, for presser foot bottom on Style 51400 AC - - - - -	23
22799 G	Hinge Screw, length overall, 25/64 inch, diameter .088 inch, for presser foot bottoms on Styles 51200 P - - - - -	23
22799 N	Screw, for cloth plate slide, rear, on Styles 51200 A, 51200 B, 51200 C, 51200 D, 51200 G, 51200 H, 51200 J, 51200 U, 51200 V, 51400 A, 51400 B, 51400 C, 51400 D, 51400 E, 51400 F, 51400 H, 51400 J, 51400 K, 51400 M, 51400 N, 51400 AC, 51600 A, 51700 C, 51700 D, 51700 E, 51700 F, 51700 G, 51700 H, 51700 T	23
22799 P	Hinge Screw, headless, 29/64 inch long, diameter .088 inch, for presser foot bottom on Style 51200 U - - - - -	23
22801	Stop Screw, for stitch regulating stud, also needle guard pivot screw - - - - -	23
22810	Clamp Screw, for thread stand lead eyelet ball socket on Styles "G" and "H" thread stands -	23
22813	Screw, headless, for lifter treadle pin - - -	20
22819	Needle Bar Set Screw, for Styles 51200 U, 51200 V - - - - -	20
22829	Locking Screw, for looper rocker cone nut; also for Nos. 51293 M, 51293 N - - - - -	21

LIST OF PARTS

Symbol to Order By	The figures in the last column refer only to the plates illustrating the parts and are not to be used in ordering. Prices furnished on application.	Plate No.
22830	Set Screw, for presser feet on Styles 51200 U, 51200 V- - - - -	21
22833	Screw, for parallel take-up cast-off on Style 51400 G- - - - -	24
22834	Stud, for regulating needle rear guard; also for Nos. K57283, K59080- - - - -	24
22835	Stud, for looper rocker link on Class 51700- -	24
22837	Thumbscrew, for face plate- - - - -	24
22839	Screw, fillister head, for throat plate support; also for No. 51401 C - - - - -	21
22840	Adapter Screw, for frame thread eyelet - - - -	24
22840 A	Screw, for regulating presser foot bottom on Styles 51200 B, 51200 C, 51200 L, 51200 M, 51400 E, 51400 T - - - - -	20
22841 B	Cloth Plate Supporting Stud, for Styles 51200 U, 51200 V- - - - -	46
22841 C	Cloth Plate Support Stud, for Styles 51400 G, 51400 AC, 51600 A, 51700 T - - - - -	46
22845 B	Pivot Screw, for cloth plate cover spring on Styles 51200 M, 51200 N, 51200 R, 51200 S, 51200 T, 51400 P, 51400 Q, 51400 R, 51400 S, 51400 T, 51400 U, 51400 V, 51400 W, 51400 X, 51400 Y, 51400 AA, 51400 AB, 51700 J, 51700 K, Nos. 32 and 40 gauge Style 51700 L, Styles 51700 N, 51700 P, 51700 Q, 51700 R - - - - -	23
22848	Screw, for oil reservoir back cover on Styles 51200 K, 51200 L, 51200 M, 51200 N, 51200 R, 51200 S, 51200 T, 51400 P, 51400 Q, 51400 R, 51400 S, 51400 T, 51400 U, 51400 V, 51400 W, 51400 X, 51400 Y, 51400 AA, 51400 AB, 51700 J, 51700 K, 51700 L, 51700 M, 51700 N, 51700 P 51700 Q, 51700 R, 51700 U; also for Nos. 51235 N, 51239 K, 51758, 52835 N, 52885 G, 52885 H- - - - -	21
22849	Screw, right, for upper crank chamber cover, also for No. 51282 J - - - - -	21
22863	Adjusting Screw, for feed dog holder - - - - -	24
22863 A	Folder Base Regulating Screw, for Styles 51400 B, 51400 C, 51400 Q, 51400 R, 51700 C, 51700 D, 51700 J, 51700 K, 51700 Q- - - - -	24
22864	Needle Lever Link Pin Clamp Screw, for styles in Class 51400, 51700, Styles 51200 K, 51200 L, 51200 M, 51200 N, 51200 R, 51200 S, 51200 T, 51600 A- - - - -	22
22868 A	Differential Feed Regulating Stud, for Styles 51200 V, 51400 AC, 51600 A (washer No. 39236 A, nut No. 907)- - - - -	22
22872	Screw for crankshaft chamber cover, upper rear, on Styles 51200 U, 51200 V, 51400 G, 51400 AC, 51600 A, 51700 T - - - - -	23

LIST OF PARTS

Symbol to Order By	The figures in the last column refer only to the plates illustrating the parts and are not to be used in ordering. Prices furnished on application.	Plate No.
22874	Screw, front, for oil reservoir baffle plate on Styles 51700 M, 51700 N, 51700 U; also for Nos. K55310, K58494, K58495, K59002 - - - - -	21
22882 A	Clamp Screw, for looper drive lever No. 51242 N - - - - -	22
23100	Double Edge Folder and Guide, 3/64 inch capacity, for Styles 51200 G, 51200 R, (screw No. 25 C) - - - - -	35
23144 A	Spring Washer, for folder swinging arm on Styles 51200 U, 51200 V - - - - -	26
23168 Q	Hemmer, for 7/8 inch hem on No. 48 gauge Styles 51400 N, 51400 AB (screw No. 25 C)	54
23168 R	Hemmer, for 5/8 inch hem on No. 32 gauge Styles 51400 F, 51400 U (screw No. 25 C) -	54
23215 BC-5/8	Binder, for selvage edge and prefolded binding 5/8 inch wide, 5/32 inch capacity, for body fabric on Styles 51200 B, 51200 L (screw No. 90) - - - - -	36
23215 BC-3/4	Binder, for selvage edge and prefolded binding 3/4 inch wide (screw No. 90) - - -	36
23215 BC-7/8	Binder, for selvage edge and prefolded binding 7/8 inch wide (screw No. 90) - - -	36
23229 M	Folder Swinging Arm Support, for Styles 51400 B, 51400 C, 51400 Q, 51400 R, 51700 C, 51700 D, 51700 G, 51700 H, 51700 J, 51700 K, 51700 N, 51700 P, 51700 Q (screw No. 93) - - - - -	37
23229 N	Folder Swinging Arm (pivot screw No. 22773, thumbscrew No. 25 T) - - - - -	36
23229 P	Folder Bracket, for Styles 51400 B, 51400 C, 51400 Q, 51400 R, 51700 C, 51700 D, 51700 H, 51700 J, 51700 K, 51700 Q (screw No. 22528) - - - - -	37
23229 Q	Folder Clamp, for Styles 51400 B, 51400 C, 51400 Q, 51400 R, 51700 C, 51700 D, 51700 H, 51700 J, 51700 K, 51700 Q (screw No. 25 S, regulating screw No. 22863 A) - - - - -	37
23253 B	Folder, upper, for gathering and stitching flounce to body of petticoats on Nos. 10, 12, and 16 gauge Style 51600 A (screw No. 22561) - - - - -	33
23253 F	Folder, lower, for turning edge of flounce on Nos. 10, 12, and 16 gauge Style 51600 A (screw No. 25 C) - - - - -	33
23279 D	Folder Threader - - - - -	50
23293 N	Lower Folder Support, for Styles 51700 T, 51700 U (screw No. 22548) - - - - -	53

LIST OF PARTS

Symbol to Order By	The figures in the last column refer only to the plates illustrating the parts and are not to be used in ordering. Prices furnished on application.	Plate No.
23293 P-96	Folder, lower, for No. 96 gauge Styles 51700 T, 51700 U, uses strip 2 1/2 inches wide, finished width 1 3/4 inches (screw No. 25 C) - - - - -	55
23300 G	Piping Guide, uses bias cut strip 5/8 inch wide and 3/32 inch diameter cord for Styles 51700 G, 51700 H, 51700 N, 51700 P (screw No. 187 A) - - - - -	35
23322 AB-3/4	Binder, for cut edge binding 3/4 inch wide, finishes 7/32 inch, 1/8 inch capacity for body fabric on Styles 51200 A, 51200 K - - - - -	36
23322 AB-7/8	Binder, for cut edge binding 7/8 inch wide, finishes 1/4 inch, 1/8 inch capacity for body fabric - - - - -	36
23322 AB-1	Binder, for cut edge binding, 1 inch wide, finishes 9/32 inch, 1/8 inch capacity for body fabric - - - - -	36
23322 AB-1 1/8	Binder, for cut edge binding 1 1/8 inches wide, finishes 11/32 inch, 5/32 inch capacity for body fabric - - - - -	36
23322 AB-1 1/4	Binder, for cut edge binding, 1 1/4 inches wide, finishes 13/32 inch, 5/32 inch capacity for body fabric - - - - -	36
23322 AC	Binder Screw No. 90 Binder Support, for Styles 51200 A, 51200 K (screw No. 90) - - - - -	36
23324 G	Collapsible Folder Connection Link, for Styles 51700 F, 51700 M (stud No. 134) -	36
23324 H	Collapsible Folder Operating Lever (stud No. 22557) - - - - -	37
23324 J	Collapsible Folder Operating Lever Stop (screw No. 25 CC) - - - - -	35
23324 R	Collapsible Folder Connection, upper (adjusting screw No. 98 A, pivot stud No. 402) - - - - -	53
23324 U	Scroll Connection Guide, for Styles 51700 F, 51700 M (screw No. 93 A) - - - -	37
23324 V	Scroll Connection Guide Support (screw No. 93 A) - - - - -	37
23325 T-120	Folder, upper, for turning edge of garment on Nos. 96 gauge Styles 51700 T, 51700 U (screw No. 25 C) - - - - -	55
23360 C-1 1/2	Collapsible Folder, for 1 1/2 inch overall bands, uses strip cut 3 3/4 inches wide on No. 88 gauge Styles 51700 F, 51700 M (screw No. 25 C) - - - - -	54
23360 F-1/2	Folder, for 1/2 inch button stay on Styles 51200 J, 51200 T, uses strip cut 1 1/2 inches wide (screw No. 25 C)	54

LIST OF PARTS

Symbol to Order By	The figures in the last column refer only to the plates illustrating the parts and are not to be used in ordering. Prices furnished on application.	Plate No.
23386 E-7/16	Reverse Hemmer, with shiftable elastic, for hemming bloomers with 7/16 inch hem on Style 51400 G- - - - -	55
23386 E-15/32	Reverse Hemmer, for 15/32 inch hem- - - - -	55
23386 E-1/2	" " for 1/2 inch hem- - - - -	55
23386 E-9/16	" " for 9/16 inch hem - - - - -	55
23386 E-19/32	" " for 19/32 inch hem- - - - -	55
23386 E-5/8	" " for 5/8 inch hem- - - - -	55
23401 J-56	Reverse Hemmer Screw No. 25 C. Center Plait Folder, "Tru-Front" type, 1/32 inch capacity, for No. 56 gauge Styles 51700 C, 51700 D, 51700 J, 51700 K, plait extends 5/16 inch beyond the rows of stitches, finish width 1 1/2 inches, uses plait cut 2 5/8 inches and interlining strip cut 1 15/32 inches- - - - -	55
23401 K-48	Center Plait Folder, "Tru-Front" type, 1/32 inch capacity, for No. 48 gauge Styles 51400 B, 51400 C, 51400 Q, 51400 R; plait extends 1/4 inch beyond the rows of stitches, finish width 1 1/4 inches, uses plait cut 2 1/4 inches and interlining strip cut 1 7/32 inches- - - - -	55
23401 K-56	Center Plait Folder, "Tru-Front" type, 1/32 inch capacity, for No. 56 gauge Styles 51700 C, 51700 J, plait extends 1/4 inch beyond the rows of stitches, finish width 1 3/8 inches, uses plait cut 2 3/8 inches and interlining strip cut 1 11/32 inches- - - - -	55
23401 K-64	Center Plait Folder, "Tru-Front" type, 1/32 inch capacity, for No. 64 gauge Styles 51700 C, 51700 D, 51700 J, 51700 K, plait extends 1/2 inch beyond the rows of stitches, finish width 1 1/2 inches, uses plait cut 2 1/2 inches and interlining strip cut 1 15/32 inches - - - - -	55
23402 D	Attaching Screw No. 93 A. Folder Support, for use with No. 23406 A-5/8 on Style 51200 U; also for Styles 51400 M, 51400 AA (screw No. 25 C)- - - - -	37
23403-48	Angular Strip Guide, reversible, for No. 48 gauge, Styles 51400 B, 51400 C, 51400 Q, 51400 R - - - - -	35
23403-56	Angular Strip Guide, reversible, for No. 56 gauge Styles 51700 C, 51700 J - - - - -	35



LIST OF PARTS

Symbol to Order By	The figures in the last column refer only to the plates illustrating the parts and are not to be used in ordering. Prices furnished on application.	Plate No.
23403-64	Angular Strip Guide, reversible, for No. 64 gauge, Styles 51700 C, 51700 D, 51700 J, 51700 K- - - - -	35
23404 B	Angular Strip Guide Screw No. 25 B. Edge Guide, for body of garment on Styles 51700 F, 51700 M (screw No. 25 C) - - - - -	34
23404 E	Edge Guide, for body of garment on Styles 51400 B, 51400 Q, 51700 D, 51700 K (screw No. 25 C)- - - - -	34
23405 F	Folder, for turning body of garment upwardly, 1/32 inch capacity, 5/16 inch fold, on Style 51400 Y (screw No. 25 C) - - - - -	35
23405 J	Folder, for turning body of garment downwardly, 1/32 inch capacity, 5/16 inch fold on Styles 51400 D, 51400 S (screw No. 25 C)- - - - -	33
23405 L	Folder, for turning body of garment upwardly, 1/32 inch capacity, 5/16 inch fold on Styles 51400 C, 51400 R, 51700 C, 51700 J (screw No. 25 C) - -	34
23405 N	Folder, for turning edge of sleeve up- wardly, 1/16 inch capacity, 1/4 inch fold on Styles 51700 G, 51700 H, 51700 N, 51700 P (screw No. 25 C) - -	35
23406 A-5/8	Folder, 1/32 inch capacity, for attach- ing 5/8 inch button stays to garments made from woven fabrics, uses strip cut 1 3/4 inches wide; used with support No. 23402 D for Style 51200 U (folder screw No. 22730)- - - - -	55
23406 B-7/8	Folder, for 7/8 inch button stays, uses 2 1/4 inch strip on Styles 51400 M, 51400 AA (screw No. 22730)- - - - -	54
23420 U-6-1/32	Lap Seam Feller Assembly, 1/32 inch capacity, for No. 6 gauge Styles 51400 A, 51400 P; one each Nos. 23422 U-1/32, 28, 23421 U-6-1/32, 23425 V. Specify component parts in ordering- - - - -	33
23420 U-8-1/32	Lap Seam Feller Assembly, 1/32 inch capacity, for No. 8 gauge Styles 51400 A, 51400 P; one each Nos. 23442 U-1/32, 28, 23421 U-8-1/32, 23425 V. Specify component parts in ordering- - - - -	33

LIST OF PARTS

Symbol to Order By	The figures in the last column refer only to the plates illustrating the parts and are not to be used in ordering. Prices furnished on application.	Plate No.
23420 U-8-1/16	Lap Seam Feller Assembly, 1/16 inch capacity, for No. 8 gauge Styles 51400 A, 51400 P; one each Nos. 23422 U-1/16, 28, 2341 U-8-1/16, 23425 V. Specify component parts in ordering-	
23420 U-10-1/32	Lap Seam Feller Assembly, 1/32 inch capacity, for No. 10 gauge Styles 51400 A, 51400 P; one each Nos. 23422 U-1/32, 28, 23421 U-10-1/32, 23425 V. Specify component parts in ordering - - - - -	33
23420 U-10-1/16	Lap Seam Feller Assembly, 1/16 inch capacity; one each Nos. 23422 U-1/16, 28, 23421 U-10-1/16, 23425 V. Specify component parts in ordering	33
23420 U-12-1/32	Lap Seam Feller Assembly, 1/32 inch capacity, for No. 12 gauge Styles 51400 A, 51400 P; one each Nos. 23442 U-1/32, 28, 23421 U-12-1/32, 23425 V. Specify component parts in ordering - - - - -	33
23420 U-12-1/16	Lap Seam Feller Assembly, 1/16 inch capacity; one each Nos. 23442 U-1/16, 28, 23421 U-12-1/16, 23425 V. Specify component parts in ordering- - - - -	33
23420 U-12-3/32	Lap Seam Feller Assembly, 3/32 inch capacity, one each Nos. 23422 U-3/32, 28, 23421 U-12-3/32, 23425 V. Specify component parts in ordering- - - - -	33
23420 U-16-1/16	Lap Seam Feller Assembly, 1/16 inch capacity, for No. 16 gauge Styles 51400 A, 51400 P; one each Nos. 23422 U-1/16, 28, 23421 U-16-1/16, 23425 V. Specify component parts in ordering - - - - -	33
23420 U-16-3/32	Lap Seam Feller Assembly, 3/32 inch capacity; one each Nos. 23422 U-3/32, 28, 23421 U-16-3/32, 23425 V. Specify component parts in ordering- - - - -	33
23420 U-16-1/8	Lap Seam Feller Assembly, 1/8 inch capacity; one each Nos. 23422 U-1/8, 28, 23421 U-16-1/8, 23425 V. Specify component parts in ordering- - - - -	33
23420 U-18-1/16	Lap Seam Feller Assembly, 1/16 inch capacity, for No. 18 gauge Styles 51400 A, 51400 P; one each Nos. 23442 U-1/16, 28, 23421 U-18-1/16, 23425 V. Specify component parts in ordering - - - - -	33

LIST OF PARTS

Symbol to Order By	The figures in the last column refer only to the plates illustrating the parts and are not to be used in ordering. Prices furnished on application.	Plate No.
23420 U-18-3/32	Lap Seam Feller Assembly, 3/32 inch capacity; one each Nos. 23422 U-3/32, 28, 23421 U-18-3/32, 23425 V. Specify component parts in ordering - - - -	33
23420 U-18-1/8	Lap Seam Feller Assembly, 1/8 inch capacity; one each Nos. 23422 U-1/8, 28, 23421 U-18-1/8, 23425 V. Specify component parts in ordering - - - -	33
23420 U-26-1/16	Lap Seam Feller Assembly, 1/16 inch capacity, for No. 26 gauge Styles 51400 J, 51400 W; one each Nos. 23422 U-1/16, 28, 23421 U-26-1/16, 23425 V. Specify component parts in ordering - - - -	33
23420 V-8-1/32	Lap Seam Feller Assembly, 1/32 inch capacity, for No. 8 gauge Styles 51400 E, 51400 T; one each Nos. 23422 V-1/32, 28, 23421 V-8-1/32, 23425 V. Specify component parts in ordering - - - -	33
23420 V-10-1/32	Lap Seam Feller Assembly, 1/32 inch capacity, for No. 10 gauge; one each Nos. 23422 V-1/32, 28, 23421 V-10-1/32, 23425 V. Specify component parts in ordering - - - -	33
23420 V-12-1/32	Lap Seam Feller Assembly, 1/32 inch capacity, for No. 12 gauge; one each Nos. 23422 V-1/32, 28, 23421 V-12-1/32, 23425 V. Specify component parts in ordering - - - -	33
23420 V-16-1/32	Lap Seam Feller Assembly, 1/32 inch capacity, for No. 16 gauge; one each Nos. 23422 V-1/32, 28, 23421 V-16-1/32, 23425 V. Speciy component parts in ordering - - - -	33
23421 U-6-1/32	Upper Scroll, for lap seam feller, 1/32 inch capacity, for No. 6 gauge Styles 51400 A, 51400 P - - - -	33
23421 U-8-1/32	Upper Scroll, 1/32 inch capacity, for No. 8 gauge - - - -	33
23421 U-8-1/16	Upper Scroll, 1/16 inch capacity - - - -	33
23421 U-10-1/32	" " 1/32 inch capacity, for	33
23421 U-10-1/16	" " No. 10 gauge - - - -	33
23421 U-12-1/32	" " 1/32 inch capacity, for	33
23421 U-12-1/16	" " No. 12 gauge - - - -	33
23421 U-12-3/32	" " 1/16 inch capacity - - - -	33
23421 U-16-1/16	" " 3/32 inch capacity - - - -	33
23421 U-16-3/32	" " 1/16 inch capacity, for No. 16 gauge - - - -	33
23421 U-16-3/32	" " 3/32 inch capacity - - - -	33

LIST OF PARTS

Symbol to Order By	The figures in the last column refer only to the plates illustrating the parts and are not to be used in ordering. Prices furnished on application.	Plate No.
23421 U-16-1/8	Upper Scroll 1/8 inch capacity- - - - -	33
23421 U-18-1/16	" " 1/16 inch capacity, for No. 18 gauge - - - - -	33
23421 U-18-3/32	" " 3/32 inch capacity - - - - -	33
23421 U-18-1/8	" " 1/8 inch capacity- - - - -	33
23421 U-26-1/16	Upper Scroll, 1/16 inch capacity, for No. 26 gauge Styles 51400 J, 51400 W-	33
23421 V-8-1/32	Upper Scroll, 1/32 inch capacity, for No. 8 gauge Style 51400 E, 51400 T- -	33
23421 V-10-1/32	Upper Scroll, 1/32 inch capacity, for No. 10 gauge- - - - -	33
23421 V-12-1/32	Upper Scroll, 1/32 inch capacity, for No. 12 gauge- - - - -	33
23421 V-16-1/32	" " 1/32 inch capacity, for No. 16 gauge- - - - -	33
23422 U-1/32	Upper Scroll Screw No. 28 Lower Scroll and Base, for lap seam feller, 1/32 inch capacity, for Nos. 6, 8, and 10 gauge Styles 51400 A, 51400 P - - - - -	34
23422 U-1/16	Lower Scroll and Base, 1/16 inch capacity, for Nos. 12, 16 and 18 gauge Styles 51400 A, 51400 P; also for No. 26 gauge Styles 51400 J, 51400 W - - - - -	34
23422 V-1/32	Lower Scroll and Base, 1/32 inch capacity, for Styles 51400 E, 51400 T - - - - -	34
23425 T	Lower Scroll and Base Screw No. 25 C. Washer Plate, for binder on Styles 51200 A, 51200 B, 51200 K, 51200 L- -	31
23425 U	Washer Plate, .025 inch thick, for cloth plate attachments- - - - -	34
23425 V	Washer Plate, .050 inch thick - - - - -	34
23432	Folder Clamp, for upper folder on Style 51200 V (screw No. 25 CC) - - -	37
23432 A	Folder Clamp, for upper folder on Styles 51700 G, 51700 H, 51700 N, 51700 P (screw No. 25 CC) - - - - -	37
23435-32	Facing Strip Folder, 1/32 inch capacity, uses 1 inch strip, finishes 5/8 inch, for No. 32 gauge Styles 51400 D, 51400 S - - - - -	54
23435-48	Facing Strip Folder, 1/32 inch capacity, uses 1 1/4 inch strip, finishes 7/8 inch for No. 48 gauge Styles 51400 B, 51400 D, 51400 Q, 51400 S- -	54
23435-64	Facing Strip Folder, 1/32 inch capacity, uses 1 1/2 inch strip, finishes 1 1/8 inches, for No. 64 gauge Styles 51700 D, 51700 K- - - - -	54
	Facing Strip Folder Washer No. 9255 Facing Strip Folder Screw No. 22548	

LIST OF PARTS

Symbol to Order By	The figures in the last column refer only to the plates illustrating the parts and are not to be used in ordering. Prices furnished on application.	Plate No.
23436	Facing Strip Folder Bracket, for Styles 51400 B, 51400 D, 51400 Q, 51400 S, 51700 D, 51700 K, 51700 R, (washer No. 9255, screw No. 136) - - - - -	37
23437 A	Binder Bracket, for Styles 51200 B, 51200 L (washer No. 12957 E, screw No. 22735) - - -	36
23437 B	Binder Bracket Support (screw No. 22585) - - -	36
23438 A	Supplemental Guide Plate, for Styles 51200 A, 51200 K (screw No. 25 C) - - - - -	35
23438 B	Supplemental Guide Platform, for Styles 51200 B, 51200 L (screw No. 90) - - - - -	35
23439 A	Pin Tension for Styles 51200 A, 51200 B, 51200 K, 51200 L (screw No. 90) - - - - -	35
23439 B	Pin Tension Assembly, for Style 51200 V (attaching screw No. 22548) - - - - -	53
23439 C	Pin Tension Adjustable Pin, for Style 51200 V, (thumb screw No. 188 D) - - - - -	53
23447-64	Strip Folder, for No. 64 gauge Styles 51700 E, 51700 L - - - - -	36
23447-72	Strip Folder, for No. 72 gauge - - - - -	36
23447-80	Strip Folder, for No. 80 gauge - - - - -	36
23447 A	Strip Folder Guide (screw No. 22593) - - - - -	35
23447 B	Strip Folder Bracket (screw No. 22548) - - - - -	37
23447 C	Strip Folder Sliding Base Spring (screw No. 22593) - - - - -	31
23448-64	Guide, for leading strip to feed dog on No. 64 gauge Styles 51700 E, 51700 L - - - - -	38
23448-72	Guide, for No. 72 gauge - - - - -	38
23448-80	Guide, for No. 80 gauge - - - - -	38
	Guide screw No. 22504	
	Guide Spring No. 51785	
	Guide Washer No. 8372 A	
23449	Body Folder, complete, 1/16 inch capacity, for Nos. 64, 72, and 80 gauge Styles 51700 E, 51700 L; (sliding base No. 23449 A, sliding base guide No. 23449 B, spring No. 23449 C, spring attaching screw No. 187 A, pivot stud No. 22735, pivot stud washer No. 12957 E, stripper blade adjusting stud No. 22532, stripper blade set screw No. 88, body folder attaching screw No. 25 C) - - - - -	34
23449 A	Body Folder Sliding Base, for Styles 51700 E, 51700 L (pivot screw No. 22735, pivot screw washer No. 12957 E) - - - - -	37
23449 B	Body Folder Sliding Base Guide (screw No. 605 A) - - - - -	35
23449 C	Body Folder Spring (screw No. 187 A) - - - - -	31
28577	Washer, for rear knee press shaft bracket on assembly No. 21693 A - - - - -	26
28604 G	Straight Mineral Oil, SAE-10 "W", put up in 10 fluid ounces to can, which is the capac- ity of machine - - - - -	--

LIST OF PARTS

Symbol to Order By	The figures in the last column refer only to the plates illustrating the parts and are not to be used in ordering. Prices furnished on application.	Plate No.
28606-1/2	Powdered Oil Stone, 1/2 lb. package- - - - -	--
28606-1	" " " 1 lb. package- - - - -	--
28619	Puller Presser Roller Axle Spring Ball, also for plugging hole in main oil reser- voir on Styles 51700 F, 51700 G, 51700 T- -	19
29066 F	Needle Lever Connecting Rod Upper Bearing Assembly; one each Nos. 51216 A, 51243 B -	40
*29105 A	Looper Drive Eccentric Assembly, external oiling, includes eccentric No. 51443, for Styles 51200 A, 51200 G, 51200 H, 51400 G (set screw No. 98, spot screw No. 96, bearing screw, upper, No. 75 A, bearing screw, lower, No. 97 A)- - - - -	40
*29105 B	Looper Drive Eccentric Assembly, external oiling, includes eccentric No. 51343, for Styles 51200 B, 51200 C, 51200 J (set screw No. 98, spot screw No. 96, bearing screw, upper, No. 75 A, bearing screw, lower, No. 97 A) - - - - -	40
*29105 L	Looper Drive Eccentric Assembly, internal and external oiling, includes eccentric No. 51243 P, for Styles 51200 A, 51200 D, 51200 G, 51200 H, 51200 U, 51200 V, 51400 A, 51400 B, 51400 C, 51400 D, 51400 E, 51400 F, 51400 H, 51400 J, 51400 K, 51400 M, 51400 N, 51400 AC, 51600 A, 51700 C, 51700 D, 51700 E, 51700 F, 51700 G, 51700 H, 51700 T (set screw No. 98, spot screw No. 96, bearing screw, upper, No. 22559 B, bearing screw, lower, No. 22559 A)- - - - -	40
*29105 M	Looper Drive Eccentric Assembly, internal and external oiling, includes eccentric No. 51243 Q, for Styles 51200 B, 51200 C, 51200 J (set screw No. 98, spot screw No. 96, bearing screw, upper, No. 22559 B, bearing screw, lower, No. 22559 A) - - - -	40
*29105 P	Looper Drive Eccentric Assembly, includes eccentric No. 51443, for Styles 51200 K, 51200 N, 51200 R, 51200 S, 51400 P, 51400 Q, 51400 R, 51400 S, 51400 T, 51400 U, 51400 V, 51400 W, 51400 X, 51400 Y, 51400 AA, 51400 AB, 51700 J, 51700 K, 51700 L, 51700 M, 51700 N, 51700 P, 51700 Q, 51700 R, 51700 U (set screw No. 98, spot screw No. 96, bearing screw, upper No. 22559 B, bearing screw, lower, No. 22559 A) - - - - -	40

\*See Page 21

LIST OF PARTS

Symbol to Order By	The figures in the last column refer only to the plates illustrating the parts and are not to be used in ordering. Prices furnished on application.	Plate No.
*29105 Q	Looper Drive Eccentric Assembly, includes eccentric No. 51343, for Styles 51200 L, 51200 M, 51200 T, (set screw No. 98, spot screw No. 96, bearing screw, upper No. 22559 B, bearing screw, lower, No.22559 A)-	40
*29114 A	Feed Clutch Driving Eccentric Assembly, includes eccentric No. 53551, for Style 51200 V (spot Screw No. 81, set screw No. 95, bearing screw No. 22559 C, plug screw No. 22586)-	40
*29114 B	Feed Clutch Driving Eccentric Assembly, for Style 51200 U, includes eccentric No. 53551 A, spot Screw No. 81, set screw No. 95, bearing screw No. 22559 C, plug screw No. 22586)-	40
*29138 H	Puller Driving Eccentric Assembly, .203 inch throw, stitch range 7 to 13 per inch, includes eccentric No. 21703 H, for Style 51700 F (spot screw No. 81, set screw No. 95, bearing screw No. 22587)-	40
*29138 J	Puller Driving Eccentric Assembly, .156 inch throw, stitch range 11 to 16 per inch, includes eccentric No. 21703 J, for Style 51700 T (spot screw No. 81, set screw No. 95, bearing screw No. 22587)-	40
*29138 K	Puller driving Eccentric Assembly, .116 inch throw, stitch range 15 to 26 per inch, includes eccentric No. 21703 K, for Style 51700 G (spot screw No. 81, set screw No. 95, bearing screw No. 22587) -	40
*29138 M	Puller Driving Eccentric Assembly, .160 inch throw, stitch range 7 to 12 per inch, includes eccentric No. 53551 A, for Style 51400 G (spot screw No. 81, set screw No. 95, bearing screw No. 22559 C, plug screw No. 22586)-	40
*29138 Q	Puller Driving Eccentric Assembly, .203 inch throw, stitch range 7 to 13 per inch, includes eccentric No. 21703 N, for Style 51700 M (spot screw No. 81, set screw No. 95, bearing screw No. 22559 C, plug screw No. 22586 -	40
*29138 R	Puller Driving Eccentric Assembly, .156 inch throw, stitch range 11 to 16 per inch, includes eccentric No. 21703 P, for Style 51700 U (spot screw No. 81, set screw No. 95, bearing screw No. 22559 C, plug screw No. 22586)-	40

\*See Page 21

LIST OF PARTS

Symbol to Order By	The figures in the last column refer only to the plates illustrating the parts and are not to be used in ordering. Prices furnished on application.	Plate No.
*29138 S	Puller Driving Eccentric Assembly, .116 inch throw, stitch range 15 to 26 per inch, includes eccentric No. 21703 M, for Style 51700 N (spot screw No. 81, set screw No. 95, bearing screw No. 22559 C, plug screw No. 22586) - - - - -	40
29192	Looper Rocker Assembly, for styles in Class 51200; one each Nos. 51213, 15465 F, 51745 lapper together, Nos. 258A, 22829; two No. 88 - - - - -	40
29192 A	Looper Rocker Assembly, for Styles 51400 A, 51400 B, 51400 C, 51400 D, 51400 E, 51400 F, 51400 K, 51400 M, 51400 N, 51400 P, 51400 Q, 51400 R, 51400 S, 51400 T, 51400 U, 51400 X, 51400 Y, 51400 AA, 51400 AB, 51400 AC, 51600 A; Nos. 32 and 40 gauge Style 51700 L; one each Nos. 51413, 15465 F, 51745 lapper together, Nos. 258 A, 22829; two No. 88 - - - - -	40
29192 C	Looper Rocker Assembly, for Styles 51700 C, 51700 D, 51700 E, 51700 F, 51700 G, 51700 H, 51700 J, 51700 K, Nos. 64, 72, and 80 gauge Style 51700 L, Styles 51700 M, 51700 N, 51700 P, 51700 Q, 51700 R, 51700 T, 51700 U; one each Nos. 51713, 15465 F, 51745 lapped together, Nos. 258 A, 22829; two No. 88 - - - - -	40
29192 D	Looper Rocker Assembly, for Styles 51400 G, 51400 H, 51400 J, 51400 V, 51400 W; one each Nos. 51513, 15465 F, 51745 lapped together, Nos. 258 A, 22829; two No. 88 - - - - -	40
29348	Needle Lever Assembly, for Styles 51200 A, 51200 B, 51200 C, 51200 D, 51200 G, 51200 H, 51200 J, 51200 U, 51200 V; one each Nos. 51215 A, 51250 lapped together; Nos. 54, 77, 78, 35759; two each Nos. 88 A, 1286, 22519 - - - - -	58
29348 B	Needle Lever Assembly, for styles in classes 51400, 51700, Styles 51200 K, 51200 L, 51200 M, 51200 N, 51200 R, 51200 S, 51200 T, 51600 A; one each Nos. 51215 C, 51250 lapped together, Nos. 54, 78, 22864, 35759, 51250 C; two each Nos. 88 A, 1286, 22528 - - - - -	58
29402	Lifter Treadle Assembly; one each Nos. 22813, 424, 423, 422 - - - - -	53



LIST OF PARTS

Symbol to Order By	The figures in the last column refer only to the plates illustrating the parts and are not to be used in ordering. Prices furnished on application.	Plate No.
*29476 AD	Crankshaft Assembly for Styles 51200 A, 51200 D, 51200 G, 51200 H, 51200 U, 51200 V, 51400 A, 51400 B, 51400 C, 51400 D, 51400 E, 51400 F, 51400 G, 51400 H, 51400 J, 51400 K, 51400 M, 51400 N, 51400 AC, 51600 A, 51700 C, 51700 D, 51700 E, 51700 G, 51700 H; includes crankshaft No. 51422 A (bearing screw No. 75 A) - - - - -	57
*29476 AE	Crankshaft Assembly, for Styles 51700 F, 51700 T; includes crankshaft No. 51322 A (bearing screw No. 75 A) - - - - -	57
*29476 AF	Crankshaft Assembly, for Styles 51200 B, 51200 C, 51200 J; includes crankshaft No. 51222 A (bearing screw No. 75 A) - - - - -	57
*29476 AJ	Crankshaft Assembly, for Styles 51200 K, 51200 N, 51200 R, 51200 S, 51400 P, 51400Q, 51400 R, 51400 S, 51400 T, 51400 U, 51400 V, 51400 W, 51400 X, 51400 Y, 51400 AA, 51400 AB, 51700 J, 51700K, 51700 L, 51700 N, 51700 P, 51700 Q, 51700 R; includes crankshaft No. 51422 A (bearing screw No. 75 A)	57
*29476 AK	Crankshaft Assembly, for Styles 51700 M, 51700 U; includes crankshaft No. 51322 A (bearing screw No. 75 A) - - - - -	57
*29476 AY	Crankshaft Assembly, for Styles 51200 L, 51200 M, 51200 T includes crankshaft No. 51222 A (bearing screw No. 75 A) - - - - -	57
29730 A	Parallel Take-up Assembly, for Style 51400 G; one each Nos. 51423, 89, 22764 A, 22833, 51404, 51461, 51461 A, 51461 B, 51461 C; three No. 22794 B- - - - -	
35167 B	Dowel Pin, for top roller feed clutch bracket, on Styles 51200 U, 51200 V- - - - -	29
35731 A	Presser Bar Connection Guide Plate (screw No. 22513) - - - - -	31
35733 B	Presser Spring Regulating Screw Lock Nut - - - - -	25
35759	Needle Bar Connection (needle bar set screw No. 88 A, link pin set screw No. 78) - - - - -	28
35768 A	Screw, left, for upper crank chamber cover - - - - -	24
35788 B	Crank Chamber Reservoir Cover, for Styles 51200 A, 51200 B, 51200 C, 51200 D, 51200G, 51200 H, 51200 J, 51200 U, 51200 V, 51400 A, 51400 B, 51400 C, 51400 D, 51400 E, 51400 F, 51400 G, 51400 H, 51400 J, 51400 K, 51400 M, 51400 N, 51400 AC, 51600 A, 51700 C, 51700 D, 51700 E, 51700 F, 51700 G, 51700 H, 51700 T (screw No. 605)- - - - -	47
35833 C	Presser Spring plate - - - - -	39

\*See Page 21

LIST OF PARTS

Symbol to Order By	The figures in the last column refer only to the plates illustrating the parts and are not to be used in ordering. Prices furnished on application.	Plate No.
39132 V	End Cover Spring Pin, for Styles 51200 U, 51200 V, 51400 G, 51400 AC, 51600 A, 51700 T, also for Nos. 52885 G, 52885 H- - - - -	29
39135	Feed Bar Shaft, 2 inches long for Styles 51200 A, 51200 B, 51200 C, 51200 D, 51200 G, 51200 H, 51200 J, 51200 U, 51200 V, 51400 A, 51400 B, 51400 C, 51400 D, 51400 E, 51400 F, 51400 G, 51400 H, 51400 J, 51400 K, 51400 M, 51400 N, 51400 AC, 51600 A, 51700 C, 51700 D, 51700 E, 51700 F, 51700 G, 51700 H, 51700 T (set screw No. 22560 B) - - - - -	45
39141 G	Nut, for feed clutch connecting rod ball joint on Styles 51200 U, 51200 V, also for puller connecting rod ball joint on Style 51400 G -	25
39175	Feed Clutch Drive Lever Connecting Rod (nut, right thread, No. 18, left thread, No. 269)	46
39193	Crank Chamber Oil Reservoir Sight Gauge Assembly, for Styles 51200 A, 51200 B, 51200 C, 51200 D, 51200 G, 51200 H, 51200 J, 51200 U, 51200 V, 51400 A, 51400 B, 51400 C, 51400 D, 51400 E, 51400 F, 51400 G, 51400 H, 51400 J, 51400 K, 51400 M, 51400 N, 51400 AC, 51600 A, 51700 C, 51700 D, 51700 E, 51700 F, 51700 G, 51700 H, 51700 T; one each Nos. 39193 A, 39193 B, 660-92, 660-93, 666-49 - -	19
39193 A	Crank Chamber Oil Reservoir Sight Gauge Glass Tube Cover - - - - -	19
39193 B	Crank Chamber Oil Reservoir Sight Gauge Base -	19
39236	Differential Feed Driving Link Sliding Block, for Styles 51200 V, 51400 AC, 51600 A - - - -	30
39236 A	Needle Rear Guard Washer, also for No. 22868 A	26
39236 T	Differential Feed Driving Link, for Styles 51200 V, 51400 AC, 51600 A - - - - -	42
39237	Differential Feed Bar Guide, for Styles 51200 V, 51400 AC, 51600 A (screw No. 22743)	30
39237 D	Differential Feed Bar Guide Plate, for Styles 51200 V, 51400 AC, 51600 A (screw No. 22593)	30
39237 G	Differential Feed Bar Bushing, for Styles 51200 V, 51400 AC, 51600 A - - - - -	26
K40881	Folder, for 3/4 inch button stay, on Styles 51200 J, 51200 T, 51200 U, capacity 1/32 inch, uses 2 1/8 inch strip (screw No. 25 C, washer plate No. 23425 V) - - - - -	54
41047	Looper Connecting Rod, 2 3/8 inches long, for No. 96 and narrower gauge styles in Class 51700 (nut, right thread, No. 18, nut, left thread, No. 269) - - - - -	30

LIST OF PARTS

Symbol to Order By	The figures in the last column refer only to the plates illustrating the parts and are not to be used in ordering. Prices furnished on application.	Plate No.
41071 G	Nut, for oil tube brace, on Styles 51200 A, 51200 B, 51200 C, 51200 D, 51200 G, 51200 H, 51200 J, 51200 U, 51200 V, 51400 A, 51400 B, 51400 C, 51400 D, 51400 E, 51400 F, 51400 H, 51400 J, 51400 K, 51400 M, 51400 N, 51400 AC, 51600 A-	25
41258	Feed Clutch Roller, for Styles 51200 U, 51200 V, also for puller clutch on Style 51400 G-	26
41258 A	Clutch Roller Spring (screw No. 22704) - - - -	32
41258 B	Clutch Disc, left (screw No. 22747) - - - -	29
41258 D	Clutch Housing (spot screw No. 81, set screw No. 95) - - - -	42
41258 E	Clutch Disc, right (screw No. 22747) - - - -	29
41258 CG	Puller Clutch Lever, for Style 51400 G - - - -	43
41358	Clutch Spring Washer, for Styles 51200 U, 51200 V, 51400 G (screw No. 87 U) - - - -	26
43134 D	Feed Bar Shaft, for Styles 51200 K, 51200 L, 51200 M, 51200 N, 51200 R, 51200 S, 51200 T, 51400 P, 51400 Q, 51400 R, 51400 S, 51400 T, 51400 U, 51400 V, 51400 W, 51400 X, 51400 Y, 51400 AA, 51400 AB, 51700 J, 51700 K, 51700 L, 51700 M, 51700 N, 51700 P, 51700 Q, 51700 R, 51700 U (screw No. 22560 B) - - - -	45
43266	Tension Post Nut, for styles in Class 51700, Styles 51400 A, 51400 B, 51400 C, 51400 D, 51400 E, 51400 F, 51400 H, 51400 J, 51400 K, 51400 M, 51400 N, 51400 P, 51400 Q, 51400 R, 51400 S, 51400 T, 51400 U, 51400 V, 51400 W, 51400 X, 51400 Y, 51400 AA, 51400 AB, 51400 AC, 51600 A-	25
43281 K	Folder Swinging Arm Spring, for Styles 51200 U, 51200 V (screw No. 90) - - - -	31
43281 L	Folder Swinging Arm Latch, for Styles 51200 U, 51200 V (screw No. 22562) - - - -	29
43294 A	Oil Drain Support (screw No. 22596) - - - -	53
43294 D	Oil Drain Pipe, 3 inches long - - - -	49
43443 Q	Nut, for differential feed intermediate gear stud, on Styles 51700 E, 51700 L - - - -	25
K49640	Folder, for 7/8 inch button stay, on Styles 51200 J, 51200 T, 51200 U, 1/32 inch capacity, uses 2 3/8 inch strip (screw No. 25 C, washer plate No. 23425 V) - - - -	54
K49746	Folder, for 1 inch button stays, on Styles 51200 J, 51200 T, 51200 U, capacity 1/32 inch, uses 2 5/8 inch strip (screw No. 25 C, washer plate No. 23425 V) - - - -	54
K49995	Needle Rear Guard, for Styles 51700 G, 51700 H, 51700 N, 51700 P (pivot screw No. 22801, attaching screw No. 22585 B, washer No. 39236 A) - - - -	17

LIST OF PARTS

Symbol to Order By	The figures in the last column refer only to the plates illustrating the parts and are not to be used in ordering. Prices furnished on application.	Plate No.
K50410	Presser Foot, for No. 128 gauge Styles 51700 G, 51700 H, 51700 N, 51700 P (clamp screw No. 91, yielding section spring, left, No. 16194, yielding section spring, right, No. 8040, yielding section spring attaching screw No. 605, yielding section spring adjusting screw No. 605 A, strip guide No. 16194 B, strip guide screw No. 73 A) - - - -	12
51134	Feed Bar, including tiltable feed dog holder, for Styles in Class 51700, Styles 51200 A, 51200 B, 51200 C, 51200 D, 51200 G, 51200 H, 51200 J, 51200 K, 51200 L, 51200 M, 51200 N, 51200 R, 51200 S, 51200 T, 51400 A, 51400 B, 51400 C, 51400 D, 51400 E, 51400 F, 51400 H, 51400 J, 51400 K, 51400 M, 51400 N, 51400 P, 51400 Q, 51400 R, 51400 S, 51400 T, 51400 U, 51400 V, 51400 W, 51400 X, 51400 Y, 51400 AA, 51400 AB, (set screw No. 22560 B, feed dog supporting screw No. 538, feed dog holder adjusting screw No. 22863, link pin screw No. 77) - - - -	42
51134 A	Feed Bar, including tiltable feed dog holder, for Styles 51200 U, 51400 G (set screw No. 166, feed dog supporting screw No. 538, feed dog holder adjusting screw No. 22863, link pin screw No. 77) - - - -	42
51134 G	Feed Dog Holder, tiltable, nut No. 258 A, washer No. 6042 A - - - -	17
51135	Feed Rocker, for Styles 51700 M, 51700 U (screw No. 98) - - - -	42
51145	Looper Avoid Eccentric Link. also feed lift eccentric link, for Styles 51200 K, 51200 L, 51200 M, 51200 N, 51200 R, 51200 S, 51200 T, 51400 P, 51400 Q, 51400 R, 51400 S, 51400 T, 51400 U, 51400 V, 51400 W, 51400 X, 51400 Y, 51400 AA, 51400 AB, 51700 J, 51700 K, 51700 L, 51700 M, 51700 N, 51700 P, 51700 Q, 51700 R, 51700 U - - - -	28
51147	Main Shaft Collar (screw No. 95) - - - -	26
K51165	Folder Bracket, for use with folder swinging arm on Styles 51700 G, 51700 H, 51700 N, 51700 P (screw No. 94) - - - -	37
51170 C	Needle Thread Take-up Post - - - -	24
51170 D	" " " " Lock Nut - - - -	25
51170 F	" " " Wire, for Style 51400 G (screw No. 90) - - - -	39

LIST OF PARTS

Symbol to Order By	The figures in the last column refer only to the plates illustrating the parts and are not to be used in ordering. Prices furnished on application.	Plate No.
51190 D	Main Shaft Bearing Housing Gasket, for Styles 51200 K, 51200 L, 51200 M, 51200 N, 51200 R, 51200 S, 51200 T, 51400 P, 51400 Q, 51400 R, 51400 S, 51400 T, 51400 U, 51400 V, 51400 W, 51400 X, 51400 Y, 51400 AA, 51400 AB, 51700 J, 51700 K, 51700 L, 51700 M, 51700 N, 51700 P, 51700 Q, 51700 R, 51700 U- - - - -	57
51201 B	Cloth Plate, for Styles 51200 A, 51200 B, 51200 D, No. 32 gauge Style 51400 D, Style 51400 F, using throat plates 3 1/8 inches long (screw No. 80) - - - - -	60
51201 C	Cloth Plate, for Styles 51400 P, 51400 T, 51400 U, 51400 X, 51400 Y, using throat plates 3 1/8 inches long (screw, 33/64 inch long, No. 80, screw, 21/32 inch long, No. 22574) - - - - -	60
51201 E	Cloth Plate, for Styles 51200 U, 51200 V (screw No. 80) - - - - -	60
51202	Cloth Plate Slide, rear 1 1/2 inches long, for Styles 51200 A, 51200 B, 51200 C, 51200 D, 51200 G, 51200 H, 51200 J, 51400 A, 51400 B, 51400 C, 51400 D, 51400 E, 51400 F, 51400 H, 51400 J, 51400 K, 51400 M, 51400 N, 51400 AC, 51600 A, 51700 C, 51700 D, 51700 E, 51700 F, 51700 G, 51700 H, 51700 T (stop screw No. 22799 N) - - - - -	49
51202 A	Cloth Plate Sliding Cover, for Styles 51200 U, 51200 V - - - - -	49
51205 A	Feed Dog, for Styles 51200 A, 51200 K - - - - -	8
51205 D	Feed Dog, for Styles 51200 D, 51200 N - - - - -	8
51208	Feed Dog Screw No. 22528	
51208 D	Looper, for Styles 51200 C, 51200 M - - - - - Looper for Styles 51200 D, 51200 H, 51200 J, 51200 N, 51200 P, 51200 S, 51200 T, 51200 U, 51200 V, also back looper for Styles 51400 H, 51400 V - - - - -	16
51213	Looper Set Screw No. 73	
+51215 A	Looper Rocker, for styles in Class 51200- - - - - Needle Lever, steel, includes bushing No. 51250 A for Styles 51200 A, 51200 B, 51200 C, 51200 D, 51200 G, 51200 H, 51200 J, 51200 U, 51200 V - - - - -	41
+51215 C	Needle Lever, lynite, includes bushing No. 51250 A for styles in Class 51400, 51700, Styles 51200 K, 51200 L, 51200 M, 51200 N, 51200 R, 51200 S, 51200 T, 51600 A- - - - -	58

LIST OF PARTS

Symbol to Order By	The figures in the last column refer only to the plates illustrating the parts and are not to be used in ordering. Prices furnished on application.	Plate No.
51216	Needle Lever Connecting Rod Tube (nut, left thread, No. 15430 C, nut right thread, No. 15430 D) - - - - -	46
51216 A	Needle Lever Connecting Rod Upper Bearing (screw No. 97 A) - - - - -	41
51217	Needle Bar, for Styles 51200 A, 51200 B, 51200 C, 51200 D, 51200 G, 51200 H, 51200 J, 51200 K, 51200 L, 51200 M, 51200 N, 51200 R, 51200 S, 51200 T (set screw No. 88 A) - - - - -	44
51217 A	Needle Bar, for Styles 51200 U, 51200 V, needle set screw No. 22819) - - - - -	44
51220 A	Presser Foot, for Styles 51200 A, 51200 K (clamp screw No. 91) - - - - -	10
51220 J	Presser Foot, for Styles 51200 J, 51200 T (clamp screw No. 91, yielding side spring No. 11534, yielding side spring attaching screw No. 605, yielding side spring support screw No. 187 A) - - - - -	10
51221	Pulley, grooved for round belt, working diameter 2 1/2 inches, for styles in Class 51400, Styles 51200 A, 51200 D, 51200 G, 51200 H, 51200 K, 51200 L, 51200 M, 51200 N, 51200 R, 51200 S, 51200 T, 51700 C, 51700 D, 51700 E, 51700 G, 51700 H, 51700 J, 51700 K, 51700 L, 51700 N, 51700 P, 51700 Q, 51700 R (spot screw No. 22597, set screw No. 22597 A) - - - - -	43
51222	Main Shaft, left section, for Classes 51200, 51400 - - - - -	57
51224 A	Throat Plate, for Styles 51200 A, 51200 K - - - - -	3
51244 B	Throat Plate, for Styles 51200 B, 51200 L - - - - -	3
51244 D	Throat Plate, for Styles 51200 D, 51200 N - - - - -	3
51225	Throat Plate Screws No. 22570 Needle Rear Guard, for Styles 51200 A, 51200 B, 51200 C, 51200 D, 51200 G, 51200 H, 51200 J, 51200 K, 51200 L, 51200 M, 51200 N, 51200 R, 51200 S, 51200 T, 51200 U (screw No. 22858 B, washer No. 39236 A) - - - - -	16
51235	Feed Rocker, for Styles 51200 A, 51200 B, 51200 C, 51200 D, 51200 G, 51200 H, 51200 J, 51200 K, 51200 L, 51200 M, 51200 N, 51200 R, 51200 S, 51200 T, 51200 U, 51400 A, 51400 B, 51400 C, 51400 D, 51400 E, 51400 F, 51400 G, 51400 H, 51400 J, 51400 K, 51400 M, 51400 N, 51400 P, 51400 Q, 51400 R, 51400 S, 51400 T, 51400 U, 51400 V, 51400 W, 51400 X, 51400 Y, 51400 AA, 51400 AB, 51700 C, 51700 D, 51700 E, 51700 F, 51700 G, 51700 H, 51700 J, 51700 K, 51700 L, 51700 N, 51700 P, 51700 Q, 51700 R, 51700 T (screw No. 98) - - - - -	42

LIST OF PARTS

Symbol to Order By	The figures in the last column refer only to the plates illustrating the parts and are not to be used in ordering. Prices furnished on application.	Plate No.
51235 A	Feed Rocker Arm, for Class 51700, Styles 51200 A, 51200 B, 51200 C, 51200 D, 51200 G, 51200 H, 51200 J, 51200 K, 51200 L, 51200 M, 51200 N, 51200 R, 51200 S, 51200 T, 51200 U, 51400 A, 51400 B, 51400 C, 51400 D, 51400 E, 51400 F, 51400 G, 51400 H, 51400 J, 51400 K, 51400 M, 51400 N, 51400 P, 51400 Q, 51400 R, 51400 S, 51400 T, 51400 U, 51400 V, 51400 W, 51400 X, 51400 Y, 51400 AA, 51400 AB (clamp screw No. 22519 C, washer No. 51235 G) - - - -	41
51235 B	Feed Rocker Shaft, 4 7/16 inches long, for Class 51700, Styles 51200 A, 51200 B, 51200 C, 51200 D, 51200 G, 51200 H, 51200 J, 51200 K, 51200 L, 51200 M, 51200 N, 51200 R, 51200 S, 51200 T, 51400 A, 51400 B, 51400 C, 51400 D, 51400 E, 51400 F, 51400 G, 51400 H, 51400 J, 51400 K, 51400 M, 51400 N, 51400 P, 51400 Q, 51400 R, 51400 S, 51400 T, 51400 U, 51400 V, 51400 W, 51400 X, 51400 Y, 51400 AA, 51400 AB - - - - -	45
51235 G	Feed Rocker Arm Clamp Screw Washer - - - - -	26
51235 M	Differential Feed Regulating Lever - - - - -	31
51235 N	Differential Feed Regulating Segment Plate, for Style 51200 V (screw No. 22848, nut No. 9937)	31
51235 P	Differential Feed Regulating Thumb Screw - - - - -	43
51235 Q	Differential Feed Regulating Screw Support Bracket (attaching screw No. 9663) - - - - -	31
51235 R	Ratchet Nut, for differential feed regulating screw (lock nut No. 258) - - - - -	25
51235 S	Differential Feed Regulating Ratchet Spring (screw No. 28) - - - - -	32
51236	Feed Crank Link (oil wick No. 666-19, shim No. 1248, screw No. 22569, nut No. 7947) - - - - -	28
51236 A	Feed Lift Link Pin; also looper avoid link pin, (screw No. 77) - - - - -	29
51236 B	Stitch Regulating Stud Cap (screw No. 22768) - -	31
51236 C	Feed Crank Stud (nut No. 269) - - - - -	30
51239 A	Roller Feed Clutch Stationary Lever, for Styles 51200 U, 51200 V - - - - -	43
51239 B	Roller Feed Clutch Stationary Lever Locking Pin (screw No. 22560 A) - - - - -	29
51239 C	Roller Feed Clutch Shaft, for Styles 51200 U, 51200 V - - - - -	30
51239 D	Roller Feed Driving Gear, for Styles 51200 U, 51200 V, (set screw No. 95) - - - - -	28
51239 E	Roller Feed Driven Gear, for Styles 51200 U, 51200 V (set screw No. 22580) - - - - -	28
51239 F	Roller Feed Driving Shaft, for Style 51200 U, 51200 V - - - - -	30
51239 G	Roller Feed Universal Joint, for Styles 51200 U, 51200 V (set screw No. 22580) - - - - -	28

LIST OF PARTS

Symbol to Order By	The figures in the last column refer only to the plates illustrating the parts and are not to be used in ordering. Prices furnished on application.	Plate No.
51239 H	Roller Feed Intermediate Driving Shaft, for Styles 51200 U, 51200 V- - - - -	30
51239 J	Roller Feed Clutch Bracket, for Styles 51200 U, 51200 V (attaching screw No. 318)	57
51239 K	Roller Feed Clutch Gear Cover, for Styles 51200 U, 51200 V (screw No. 22848) - - - -	61
*51239 L	Roller Feed Clutch Driving Lever Ball Joint Assembly, for Styles 51200 U, 51200 V (washer No. 9255, nut No. 39141 G) - - - -	29
51240 A	Looper Connecting Rod, adjusting section, for styles in Classes 51200, 51400, Nos. 32 and 40 gauge Style 51700 L (nut, right thread, No. 18, nut, left thread, No. 269)	30
51240 B	Looper Connecting Rod Jointed Section Sleeve, for styles in Classes 51200, 51400, Nos. 32 and 40 gauge Style 51700 L - - - - -	26
51240 C	Looper Connecting Rod Jointed Section Sleeve Spring, for styles in Classes 51200, 51400, Nos. 32 and 40 gauge Style 51700 L - - - -	32
*51241	Looper Connecting Rod, jointed section and ball joint assembly, right, for styles in Classes 51200, 51400, Nos. 32 and 40 gauge Style 51700 L, equipped with looper drive levers Nos. 51242 E, 51242 J, 51242 T, 51242 V (ball stud washer No. 36 G, bearing screw No. 97 A, jointed section sleeve No. 51240 B, sleeve spring No. 51240 C)- - - -	41
*51241 D	Looper Connecting Rod Ball Joint Assembly, left, for Styles in Classes 51200, 51400, Nos. 32 and 40 gauge Style 51700 L, equipped with looper drive levers Nos. 51242 E, 51242 J, 51242 T, 51242 V (bearing screw No. 97 A, nut No. 18)- - - - -	29
*51241 G	Looper Connecting Rod, jointed section and ball joint assembly, right, .232 inch diameter shoulder on ball stud, for styles in Classes 51200, 51400, Nos. 32 and 40 gauge Style 51700 L, equipped with looper drive levers Nos. 51242 N, 51242 U (ball stud washer No. 51741 E, bearing screw No. 97 A, jointed section sleeve No. 51240 B, sleeve spring No. 51240 C)- - - - -	41
*51242 A	Looper Drive Lever Shaft, 4 9/16 inches long, with bushing, for Styles 51200 A, 51200 B, 51200 C, 51200 D, 51200 G, 51200 H, 51200 J, 51200 U, 51200 V, 51400 A, 51400 B, 51400 C, 51400 D, 51400 E, 51400 F, 51400 G, 51400 H, 51400 J, 51400 K, 51400 M, 51400 N, 51400 AC, 51600 A, 51700 C, 51700 D, 51700 E, 51700 F, 51700 G, 51700 H, 51700 T (screw No. 22597 A) - - - - -	45



LIST OF PARTS

Symbol to Order By	The figures in the last column refer only to the plates illustrating the parts and are not to be used in ordering. Prices furnished on application.	Plate No.
51242 B	Looper Drive Lever Shaft Bushing, rear, for Styles 51200 A, 51200 B, 51200 C, 51200 D, 51200 G, 51200 H, 51200 J, 51200 U, 51200 V, 51400 A, 51400 B, 51400 C, 51400 D, 51400 E, 51400 F, 51400 G, 51400 H, 51400 J, 51400 K, 51400 M, 51400 N, 51400 AC, 51600 A, 51700 C, 51700 D, 51700 E, 51700 F, 51700 G, 51700 H, 51700 T (screw No. 22597 A) - - -	26
51242 H	Looper Drive Lever Shaft, for Styles 51200 K, 51200 L, 51200 M, 51200 N, 51200 R, 51200 S, 51200 T, 51400 P, 51400 Q, 51400 R, 51400 S, 51400 T, 51400 U, 51400 V, 51400 W, 51400 X, 51400 Y, 51400 AA, 51400 AB, 51700 J, 51700 K, 51700 L, 51700 M, 51700 N, 51700 P, 51700 Q, 51700 R, 51700 U - - - -	45
51242 K	Looper Drive Lever Rocker, for Styles 51200 K, 51200 L, 51200 M, 51200 N, 51200 R, 51200 S, 51200 T, 51400 P, 51400 Q, 51400 R, 51400 S, 51400 T, 51400 U, 51400 V, 51400 W, 51400 X, 51400 Y, 51400 AA, 51400 AB, 51700 J, 51700 K, 51700 L, 51700 M, 51700 N, 51700 P, 51700 Q, 51700 R, 51700 U (set screw No. 81, clamp screw No. 627) - -	41
51242 L-595	Looper Drive Lever Rocker Thrust Washer, .0595 inch thick, for Styles 51200 K, 51200 L, 51200 M, 51200 N, 51200 R, 51200 S, 51200 T, 51400 P, 51400 Q, 51400 R, 51400 S, 51400 T, 51400 U, 51400 V, 51400 W, 51400 X, 51400 Y, 51400 AA, 51400 AB, 51700 J, 51700 K, 51700 L, 51700 M, 51700 N, 51700 P, 51700 Q, 51700 R, 51700 U - - - - -	26
51242 L-600	Looper Drive Lever Rocker Thrust Washer, .0600 inch thick - - - - -	26
51242 L-605	Looper Drive Lever Rocker Thrust Washer, .0605 inch thick - - - - -	26
51242 L-610	Looper Drive Lever Rocker Thrust Washer, .0610 inch thick - - - - -	26
51242 L-615	Looper Drive Lever Rocker Thrust Washer, .0615 inch thick - - - - -	26
51242 L-620	Looper Drive Lever Rocker Thrust Washer, .0620 inch thick - - - - -	26

LIST OF PARTS

Symbol to Order By	The figures in the last column refer only to the plates illustrating the parts and are not to be used in ordering. Prices furnished on application.	Plate No.
51242 M	Looper Drive Lever Clamp Screw Washer, for Styles 51200 K, 51200 L, 51200 M, 51200 N, 51200 R, 51200 S, 51200 T, 51400 P, 51400 Q, 51400 R, 51400 S, 51400 T, 51400 U, 51400 V, 51400 W, 51400 X, 51400 Y, 51400 AA, 51400 AB, 51700 J, 51700 K, 51700 L, 51700 M, 51700 N, 51700 P, 51700 Q, 51700 R, 51700 U - - - - -	26
51242 N	Looper Drive Lever, steel, with .232 inch diameter reamed hole, for ball stud, clamping lug on left, for Styles 51200 K, 51200 L, 51200 M, 51200 N, 51200 R, 51200 S, 51200 T, 51400 P, 51400 Q, 51400 R, 51400 S, 51400 T, 51400 U, 51400 V, 51400 W, 51400 X, 51400 Y, 51400 AA, 51400 AB, 51700 J, 51700 K, 51700 L, 51700 M, 51700 N, 51700 P, 51700 Q, 51700 R, 51700 U (spot screw No. 81, clamping screw No. 22882 A, washer No. 51242 M) - - - - -	41
51242 Q	Looper Drive Lever Shaft Bushing, front; for Styles 51200 K, 51200 L, 51200 M, 51200 N, 51200 R, 51200 S, 51200 T, 51400 P, 51400 Q, 51400 R, 51400 S, 51400 T, 51400 U, 51400 V, 51400 W, 51400 X, 51400 Y, 51400 AA, 51400 AB, 51700 J, 51700 K, 51700 L, 51700 M, 51700 N, 51700 P, 51700 Q, 51700 R, 51700 U - - - - -	21
51242 R	Looper Drive Lever Shaft Bushing, middle, for Styles 51200 K, 51200 L, 51200 M, 51200 N, 51200 R, 51200 S, 51200 T, 51400 P, 51400 Q, 51400 R, 51400 S, 51400 T, 51400 U, 51400 V, 51400 W, 51400 X, 51400 Y, 51400 AA, 51400 AB, 51700 J, 51700 K, 51700 L, 51700 M, 51700 N, 51700 P, 51700 Q, 51700 R, 51700 U - - - - -	26
51242 S	Looper Drive Lever Shaft Bushing, rear for Styles 51200 K, 51200 L, 51200 M, 51200 N, 51200 R, 51200 S, 51200 T, 51400 P, 51400 Q, 51400 R, 51400 S, 51400 T, 51400 U, 51400 V, 51400 W, 51400 X, 51400 Y, 51400 AA, 51400 AB, 51700 J, 51700 K, 51700 L, 51700 M, 51700 N, 51700 P, 51700 Q, 51700 R, 51700 U - - - - -	26
51242 T	Looper Drive Lever, steel, with threaded hole for ball stud, for Styles 51200 A, 51200 B, 51200 C, 51200 D, 51200 G, 51200 H, 51200 J, 51200 U, 51200 V, 51400 A, 51400 B, 51400 C, 51400 D, 51400 E, 51400 F, 51400 G, 51400 H, 51400 J, 51400 K, 51400 M, 51400 N, 51400 AC, 51600 A, 51700 C, 51700 D, 51700 E, 51700 F, 51700 G, 51700 H, 51700 T - - - - -	41

LIST OF PARTS

Symbol to Order By	The figures in the last column refer only to the plates illustrating the parts and are not to be used in ordering. Prices furnished on application.	Plate No.
51242 U	Looper Drive Lever, steel, with .232 inch diameter reamed hole for ball stud, for Styles 51200 A, 51200 B, 51200 C, 51200 D, 51200 G, 51200 H, 51200 J, 51200 U, 51200 V, 51400 A, 51400 B, 51400 C, 51400 D, 51400 E, 51400 F, 51400 G, 51400 H, 51400 J, 51400 K, 51400 M, 51400 N, 51400 AC, 51600 A, 51700 C, 51700 D, 51700 E, 51700 F, 51700 G, 51700 H, 51700 T- - - - -	41
51242 V	Looper Drive Lever, steel, with threaded hole for ball stud, for Styles 51200 K, 51200 L, 51200 M, 51200 N, 51200 R, 51200 S, 51200 T, 51400 P, 51400 Q, 51400 R, 51400 S, 51400 T, 51400 U, 51400 V, 51400 W, 51400 X, 51400 Y, 51400 AA, 51400 AB, 51700 J, 51700 K, 51700 L, 51700 M, 51700 N, 51700 P, 51700 Q, 51700 R, 51700 U (spot screw No. 81, clamp screw No. 74, washer No. 51242 M)- - - - -	41
51243 B	Looper Drive Lever Rocker Ball Stud, also needle lever ball stud (clamp screw, fillister head, No. 22528, clamp screw, hexagonal head, No. 22519) - - - - -	30
51243 C	Looper Drive Lever Ball Stud Guide Fork; also for No. 51216 A (screw No. 97) - - - - -	28
51243 E	Looper Drive Lever Connection Felt Retainer, for Looper Drive eccentric assemblies Nos. 29105 A, 29105 B - - - - -	19
51243 K	Looper Drive Eccentric Oil Disc, for looper drive eccentric assemblies Nos. 29105 L, 29105 M (screw No. 22716)- - - - -	41
51243 L	Looper Drive Eccentric Oil Disc Gasket, for looper drive eccentric assemblies Nos. 29105 L, 29105 M - - - - -	41
51243 N	Looper Drive Eccentric Oil Disc Washer, steel, for looper drive eccentric assemblies Nos. 29105 L, 29105 M (screw No. 22716 A) - - - - -	41
51243 R	Looper Drive Eccentric Felt Retainer, for looper drive eccentric assemblies Nos. 29105 L, 29105 M- - - - -	19
51244	Looper Rocker Frame, for styles in Classes 51200, 51400, (spot screw No. 96, set screw No. 98)- - - - -	41
51244 A	Looper Rock Shaft- - - - -	45
51244 B	Looper Rock Shaft Arm (clamp screw No. 93) - - -	28
51244 C	Looper Rock Shaft Sleeve, for styles in Class 51200, Styles 51400 A, 51400 B, 51400 C, 51400 D, 51400 E, 51400 F, 51400 H, 51400 J, 51400 K, 51400 M, 51400 N, 51400 P, 51400 Q, 51400 R, 51400 S, 51400 T, 51400 U, 51400 V, 51400 W, 51400 X, 51400 Y, 51400 AA, 51400 AB, 51400 AC, 51600 A (screw No. 88 B) - - - - -	27

LIST OF PARTS

Symbol to Order By	The figures in the last column refer only to the plates illustrating the parts and are not to be used in ordering. Prices furnished on application.	Plate No.
51244 E	Looper Rock Shaft Bushing, also feed rocker shaft bushing- - - - -	26
51245	Looper Avoid Eccentric Link and Feed Lift Eccentric Link, for Styles 51200 A, 51200 B, 51200 C, 51200 D, 51200 G, 51200 H, 51200 J, 51200 U, 51200 V, 51400 A, 51400 B, 51400 C, 51400 D, 51400 E, 51400 F, 51400 G, 51400 H, 51400 J, 51400 K, 51400 M, 51400 N, 51400 AC, 51600 A, 51700 C, 51700 D, 51700 E, 51700 F, 51700 G, 51700 H, 51700 T (oil retaining pad No. 51245 A, screw No. 22569, nut No. 7947)- - - - -	28
51245 A	Looper Avoid Eccentric Link Oil Retaining Pad-	19
51246	Looper Rocker Stud Nut, for styles in Classes 51200, 51400, Style 51600 A- - - - -	25
51250	Needle Lever Stud (screw No. 719)- - - - -	45
51250 A	" " " Bushing - - - - -	27
51250 B	" " Thrust Collar (screw No. 719) - -	27
51250 C	" " Link Pin Clamp Screw Nut, for styles in Classes 51400, 51700, Styles 51200K, 51200 L, 51200 M, 51200 N, 51200 R, 51200 S, 51200 T, 51600 A - - - - -	25
51254	Needle Bar Bushing, upper- - - - -	27
51254 A	Needle Bar Bushing, lower- - - - -	27
51257 A	Presser Bar Bushing, upper, for Styles 51200 A, 51200 B, 51200 C, 51200 D, 51200 G, 51200 H, 51200 J, 51200 U, 51200 V, 51400 A, 51400 B, 51400 C, 51400 D, 51400 E, 51400 F, 51400 G, 51400 H, 51400 J, 51400 K, 51400 M, 51400 N, 51400 AC, 51600 A, 51700 C, 51700 D, 51700 E, 51700 F, 51700 G, 51700 H, 51700 T - - - - -	27
51257 C	Presser Bar Bushing, lower, length overall 1 3/4 inches, for Styles 51200 A, 51200 B, 51200 C, 51200 D, 51200 G, 51200 H, 51200 J, 51400 A, 51400 B, 51400 C, 51400 D, 51400 E, 51400 F, 51400 H, 51400 J, 51400 K, 51400 M, 51400 N, 51700 C, 51700 D, 51700 E, 51700 F, 51700 G, 51700 H - - - - -	27
51257 D	Presser Bar Bushing, lower, for Styles 51200 K, 51200 L, 51200 M, 51200 N, 51200 R, 51200 S, 51200 T, 51400 P, 51400 Q, 51400 R, 51400 S, 51400 T, 51400 U, 51400 V, 51400 W, 51400 X, 51400 Y, 51400 AA, 51400 AB, 51700 J, 51700 K, 51700 L, 51700 M, 51700 N, 51700 P, 51700 Q, 51700 R, 51700 U- - - - -	27
51258	Needle Lever Thread Eyelet, for styles in Class 51200 (screw No. 22768)- - - - -	18
51258 A	Needle Bar Thread Eyelet, for styles in Class 51200 (screw No. 22768)- - - - -	18
51264	Cloth Plate Swinging Arm, for Styles 51200 U, 51200 V (pivot screw No. 236)- - - - -	61

LIST OF PARTS

Symbol to Order By	The figures in the last column refer only to the plates illustrating the parts and are not to be used in ordering. Prices furnished on application.	Plate No.
51270 B	Needle Thread Take-up, for styles in Classes 51200, 51700, Styles 51400 A, 51400 B, 51400 C, 51400 D, 51400 E, 51400 F, 51400 H, 51400 J, 51400 K, 51400 M, 51400 N, 51400 P, 51400 Q, 51400 R, 51400 S, 51400 T, 51400 U, 51400 V, 51400 W, 51400 X, 51400 Y, 51400 AA, 51400 AB, 51400 AC, 51600 A (clamping screw No. 90) - - - - -	39
51280 A	Throat Plate Support, for Styles 51200 C, 51200 G, 51200 H, 51200 J, 51200 M, 51200 R, 51200 S, 51200 T, 51400 H, 51400 J, 51400 V, 51400 W, 51700 M, (screw No. 80) - - - - -	55
51280 B	Throat Plate Support for Styles 51700 E, 51700 L (screw No. 22839) - - - - -	56
51280 G	Throat Plate Support, for Style 51400 G (screw No. 80) - - - - -	55
51281-199	Cloth Plate Cover, 6 7/32 inches long, for Styles 51700 G, 51700 H - - - - -	56
51281-204	Cloth Plate Cover, 6 17/64 inches long, for Styles 51700 E, 51700 F, Nos. 64, 72, 80 gauge Style 51700 L, 51700 M - - - - -	56
51281-206	Cloth Plate Cover, 6 27/64 inches long, for Styles 51700 T, 51700 U - - - - -	56
51281-216	Cloth Plate Cover, 6 3/4 inches long, for Styles 51200 J, 51400 B, 51400 C, No. 48 gauge Style 51400 D, Styles 51400 M, 51400 N, 51700 C, 51700 D - - - - -	56
51281-226	Cloth Plate Cover, 7 1/16 inches long, for No. 32 gauge Styles 51400 D, 51400 F - - - - -	56
51281-228	Cloth Plate Cover, 7 1/8 inches long, for Style 51200 C, No. 18 gauge Styles 51400 G, 51400 H - - - - -	56
51281-230	Cloth Plate Cover, 7 3/16 inches long for No. 24 gauge Style 51400 G - - - - -	56
51281-232	Cloth Plate Cover, 7 1/4 inches long, for No. 16 gauge, Style 51400 G - - - - -	56
51281-233	Cloth Plate Cover, 7 9/32 inches long, for Styles 51200 G, 51400 H, 51400 J, 51600 A -	56
51281 C-226	Cloth Plate Cover, 7 1/16 inches long, for Styles 51200 A, 51200 B, 51200 K, 51200 L -	56
51281 E-226	Cloth Plate Cover, 7 1/16 inches long, for Styles 51200 D, 51200 N - - - - -	56
51281 F	Cloth Plate Cover Spring, for Styles 51200 A, 51200 B, 51200 C, 51200 D, 51200 G, 51200 H, 51200 J, 51400 B, 51400 C, 51400 D, 51400 F, 51400 G, 51400 H, 51400 J, 51400 M, 51400 N, 51600 A, 51700 C, 51700 D, 51700 E, 51700 F, 51700 G, 51700 H, 51700 T, (screw No. 22726 A) - - - - -	49

LIST OF PARTS

Symbol to Order By	The figures in the last column refer only to the plates illustrating the parts and are not to be used in ordering. Prices furnished on application.	Plate No.
51281 G	Cloth Plate Cover Spring, for Styles 51200 M, 51200 R, 51200 S, 51200 T, 51400 P, 51400 Q, 51400 R, 51400 S, 51400 T, 51400 U, 51400 V, 51400 W, 51400 X, 51400 Y, 51400 AA, 51400 AB, 51700 J, 51700 K, Nos. 32 and 40 gauge Style L, Styles 51700 N, 51700 P, 51700 Q, 51700 R, (attaching screw No. 22726, attaching screw washer No. 6042 A, pivot screw No. 22845 B) - - - - -	49
51281 H-187	Cloth Plate Cover, for Styles 51400 Q, 51400 R, No. 48 gauge Style 51400 S, Styles 51400 AA, 51400 AB, 51700 J, 51700 K, 51700 Q, 51700 R - - - - -	48
51281 H-207	Cloth Plate Cover, for Style 51400 P, No. 32 gauge Style 51400 S, Styles 51400 T, 51400 U, 51400 X, 51400 Y - - - - -	48
51281 J-190	Cloth Plate Cover, for Style 51200 T - - -	48
51281 J-212	Cloth Plate Cover, for Style 51200 M, No. 18 gauge Style 51400 V - - - - -	48
51281 J-219	Cloth Plate Cover, for No. 16 gauge Style 51400 V - - - - -	48
51281 J-222	Cloth Plate Cover, for Styles 51200 R, 51400 W - - - - -	48
51281 J-227	Cloth Plate Cover, for Style 51200 S - - -	48
51281 M-155	Cloth Plate Cover, for Styles 51700 N, 51700 P - - - - -	48
51282	Louver Cover, for Style 51200 A, 51200 B, 51200 C, 51200 D, 51200 G, 51200 H, 51200 J, 51200 U, 51200 V, 51400 A, 51400 B, 51400 C, 51400 D, 51400 E, 51400 F, 51400 G, 51400 H, 51400 J, 51400 K, 51400 M, 51400 N, 51400 AC, 51600 A, 51700 C, 51700 D, 51700 E, 51700 F, 51700 G, 51700 H, 51700 T, (screw No. 90) - - - - -	49
51282 B	Face Plate, for styles in Classes 51400, 51700, Styles 51200 A, 51200 B, 51200 C, 51200 D, 51200 G, 51200 H, 51200 J, 51200 K, 51200 L, 51200 M, 51200 N, 51200 R, 51200 S, 51200 T (thumbscrew No. 22837) - - - - -	48
51282 E	Crankshaft Chamber Cover, upper, for Styles 51200 K, 51200 L, 51200 M, 51200 N, 51200 R, 51200 S, 51200 T, 51400 P, 51400 Q, 51400 R, 51400 S, 51400 T, 51400 U, 51400 V, 51400 W, 51400 X, 51400 Y, 51400 AA, 51400 AB, 51700 J, 51700 K, 51700 L, 51700 M, 51700 N, 51700 P, 51700 Q, 51700 R, 51700 U (attaching screw, right, No. 22849, attaching screw, left, No. 35768 A) - - -	56

LIST OF PARTS

Symbol to Order By	The figures in the last column refer only to the plates illustrating the parts and are not to be used in ordering. Prices furnished on application.	Plate No.
51282 F	Crankshaft Cover Oil Drip Plate, for Styles 51200 K, 51200 L, 51200 M, 51200 N, 51200 R, 51200 S, 51200 T, 51400 P, 51400 Q, 51400 R, 51400 S, 51400 T, 51400 U, 51400 V, 51400 W, 51400 X, 51400 Y, 51400 AA, 51400 AB, 51700 J, 51700 K, 51700 L, 51700 M, 51700 N, 51700 P, 51700 Q, 51700 R, 51700 U (screw No. 187 A) - -	47
51282 H	Crank Chamber Cover Gasket, for Styles 51200 A, 51200 B, 51200 C, 51200 D, 51200 G, 51200 H, 51200 J, 51200 U, 51200 V, 51400 A, 51400 B, 51400 C, 51400 D, 51400 E, 51400 F, 51400 G, 51400 H, 51400 J, 51400 K, 51400 M, 51400 N, 51400 AC, 51600 A, 51700 C, 51700 D, 51700 E, 51700 F, 51700 G, 51700 H, 51700 T - - - -	49
51282 J	Crank Chamber Oil Reservoir, for Styles 51200 A, 51200 B, 51200 C, 51200 D, 51200 G, 51200 H, 51200 J, 51200 U, 51200 V, 51400 A, 51400 B, 51400 C, 51400 D, 51400 E, 51400 F, 51400 G, 51400 H, 51400 J, 51400 K, 51400 M, 51400 N, 51400 AC, 51600 A, 51700 C, 51700 D, 51700 E, 51700 F, 51700 G, 51700 H, 51700 T (attaching screw, right, No. 22849, attaching screw, left No. 35768 A) - - - -	56
51282 L	Oil Reservoir Top Cover, for Styles 51200 K, 51200 L, 51200 M, 51200 N, 51200 R, 51200 S, 51200 T, 51400 P, 51400 Q, 51400 R, 51400 S, 51400 T, 51400 U, 51400 V, 51400 W, 51400 X, 51400 Y, 51400 AA, 51400 AB, 51700 J, 51700 K, 51700 L, 51700 M, 51700 N, 51700 P, 51700 Q, 51700 R, 51700 U (screw countersunk head, No. 22524, screw, fillister head, No. 22585 A) - -	57
51282 M	Oil Reservoir Top Cover Gasket - - - -	57
51282 N	Oil Reservoir Top Cover Oil Drip Plate (screw No. 187 A) - - - -	46
51282 Q	Oil Reservoir Back Cover, for Styles 51700 M, 51700 N, 51700 U (screw No. 22848) - - - -	56
51282 R	Oil Reservoir Back Cover, for Styles 51200 K, 51200 L, 51200 M, 51200 N, 51200 R, 51200 S, 51200 T, 51400 P, 51400 Q, 51400 R, 51400 S, 51400 T, 51400 U, 51400 V, 51400 W, 51400 X, 51400 Y, 51400 AA, 51400 AB, 51700 J, 51700 K, 51700 L, 51700 P, 51700 Q, 51700 R (screw No. 22848) - - - -	56
51282 S	Oil Reservoir Back Cover Gasket, for Styles 51200 K, 51200 L, 51200 M, 51200 N, 51200 R, 51200 S, 51200 T, 51400 P, 51400 Q, 51400 R, 51400 S, 51400 T, 51400 U, 51400 V, 51400 W, 51400 X, 51400 Y, 51400 AA, 51400 AB, 51700 J, 51700 K, 51700 L, 51700 M, 51700 N, 51700 P, 51700 Q, 51700 R, 51700 U - - - -	57

LIST OF PARTS

Symbol to Order By	The figures in the last column refer only to the plates illustrating the parts and are not to be used in ordering. Prices furnished on application.	Plate No.
51282 T	Crankshaft Chamber Cover, for Styles 51200 K, 51200 L, 51200 M, 51200 N, 51200 R, 51200 S, 51200 T, 51400 P, 51400 Q, 51400 R, 51400 S, 51400 T, 51400 U, 51400 V, 51400 W, 51400 X, 51400 Y, 51400 AA, 51400 AB, 51700 J, 51700 K, 51700 L, 51700 M, 51700 N, 51700 P, 51700 Q, 51700 R, 51700 U (screw No. 90) - - -	48
51282 U	Crankshaft Chamber Cover Gasket, for Styles 51200 K, 51200 L, 51200 M, 51200 N, 51200 R, 51200 S, 51200 T, 51400 P, 51400 Q, 51400 R, 51400 S, 51400 T, 51400 U, 51400 V, 51400 W, 51400 X, 51400 Y, 51400 AA, 51400 AB, 51700 J, 51700 K, 51700 L, 51700 M, 51700 N, 51700 P, 51700 Q, 51700 R, 51700 U - - - - -	49
51282 V	Oil Reservoir Baffle Plate, for Styles 51700 M, 51700 N, 51700 U (screw, front, No. 22874, screw, rear, No. 94) - - - - -	47
51283	Lifter Lever, for Styles 51200 A, 51200 B, 51200 C, 51200 D, 51200 G, 51200 H, 51200 J, 51400 A, 51400 B, 51400 C, 51400 D, 51400 E, 51400 F, 51400 H, 51400 J, 51400 K, 51400 M, 51400 N, 51700 C, 51700 D, 51700 E, 51700 F, 51700 G, 51700 H, (stud No. 22566 C) - - - - -	61
51283 A	Lifter Lever Spring, for Styles 51200 A, 51200 B, 51200 C, 51200 D, 51200 G, 51200 H, 51200 J, 51400 A, 51400 B, 51400 C, 51400 D, 51400 E, 51400 F, 51400 H, 51400 J, 51400 K, 51400 M, 51400 N, 51700 C, 51700 D, 51700 E, 51700 F, 51700 G, 51700 H - - - - -	32
51283 B	Lifter Lever Spring Pin, for Styles 51200 A, 51200 B, 51200 C, 51200 D, 51200 G, 51200 H, 51200 J, 51400 A, 51400 B, 51400 C, 51400 D, 51400 E, 51400 F, 51400 G, 51400 H, 51400 J, 51400 K, 51400 M, 51400 N, 51700 C, 51700 D, 51700 E, 51700 F, 51700 G, 51700 H - - - - -	29
51283 E	Lifter Lever, for Styles 51200 K, 51200 L, 51200 M, 51200 N, 51200 R, 51200 S, 51200 T, 51400 P, 51400 Q, 51400 R, 51400 S, 51400 T, 51400 U, 51400 V, 51400 W, 51400 X, 51400 Y, 51400 AA, 51400 AB, 51700 J, 51700 K, 51700 L, 51700 M, 51700 N, 51700 P, 51700 Q, 51700 R, 51700 U (stud No. 22566 A) - - - - -	61
51283 F	Lifter Lever Link, for Styles 51200 K, 51200 L, 51200 M, 51200 N, 51200 R, 51200 S, 51200 T, 51400 P, 51400 Q, 51400 R, 51400 S, 51400 T, 51400 U, 51400 V, 51400 W, 51400 X, 51400 Y, 51400 AA, 51400 AB, 51700 J, 51700 K, 51700 L, 51700 M, 51700 N, 51700 P, 51700 Q, 51700 R, 51700 U (screw No. 22758 B, stud No. 402) - - - - -	28



LIST OF PARTS

Symbol to Order By	The figures in the last column refer only to the plates illustrating the parts and are not to be used in ordering. Prices furnished on application.	Plate No.
51285 51290	Cloth Plate End Cover, for Style 51200 V - - - Main Shaft Bushing, inner right, for Styles 51200 A, 51200 B, 51200 C, 51200 D, 51200 G, 51200 H, 51200 J, 51200 U, 51200 V, 51400 A, 51400 B, 51400 C, 51400 D, 51400 E, 51400 F, 51400 G, 51400 H, 51400 J, 51400 K, 51400 M, 51400 N, 51400 AC, 51600 A, 51700 C, 51700 D, 51700 E, 51700 F, 51700 G, 51700 H, 51700 T, also main shaft bushing, inner left, for Style 51400 G - - - - -	61 27
51290 A	Main Shaft Bushing, outer right, for Styles 51200 A, 51200 B, 51200 C, 51200 D, 51200 G, 51200 H, 51200 J, 51200 U, 51200 V, 51400 A, 51400 B, 51400 C, 51400 D, 51400 E, 51400 F, 51400 G, 51400 H, 51400 J, 51400 K, 51400 M, 51400 N, 51400 AC, 51600 A, 51700 C, 51700 D, 51700 E, 51700 F, 51700 G, 51700 H, 51700 T - - - - -	27
51290 D	Main Shaft Bushing, outer left, for Styles 51200 A, 51200 B, 51200 C, 51200 D, 51200 G, 51200 H, 51200 J, 51200 U, 51200 V, 51400 A, 51400 B, 51400 C, 51400 D, 51400 E, 51400 F, 51400 G, 51400 H, 51400 J, 51400 K, 51400 M, 51400 N, 51400 AC, 51600 A, 51700 C, 51700 D, 51700 E, 51700 F, 51700 G, 51700 H, 51700 T - - - - -	27
51290 E	Main Shaft Bushing, inner left, for Styles 51200 A, 51200 B, 51200 C, 51200 D, 51200 G, 51200 H, 51200 J, 51200 U, 51200 V, 51400 A, 51400 B, 51400 C, 51400 D, 51400 E, 51400 F, 51400 H, 51400 J, 51400 K, 51400 M, 51400 N, 51400 AC, 51600 A, 51700 C, 51700 D, 51700 E, 51700 F, 51700 G, 51700 H, 51700 T - - - - -	27
51290 J	Main Shaft Bushing, inner left, for Styles 51200 K, 51200 L, 51200 M, 51200 N, 51200 R, 51200 S, 51200 T, 51400 P, 51400 Q, 51400 R, 51400 S, 51400 T, 51400 U, 51400 V, 51400 W, 51400 X, 51400 Y, 51400 AA, 51400 AB, 51700 J, 51700 K, 51700 L, 51700 M, 51700 N, 51700 P, 51700 Q, 51700 R, 51700 U - - - - -	27
51290 K	Main Shaft Bushing, outer left, for Styles 51200 K, 51200 L, 51200 M, 51200 N, 51200 R, 51200 S, 51200 T, 51400 P, 51400 Q, 51400 R, 51400 S, 51400 T, 51400 U, 51400 V, 51400 W, 51400 X, 51400 Y, 51400 AA, 51400 AB, 51700 J, 51700 K, 51700 L, 51700 M, 51700 N, 51700 P, 51700 Q, 51700 R, 51700 U; also inner right, for Styles 51200 K, 51200 L, 51200 M, 51200 N, 51200 R, 51200 S, 51200 T, 51400 P, 51400 Q, 51400 R, 51400 S, 51400 T, 51400 U, 51400 V, 51400 W, 51400 X, 51400 Y, 51400 AA, 51400 AB, 51700 J, 51700 K, 51700 L, 51700 P, 51700 Q, 51700 R - - - - -	27

LIST OF PARTS

Symbol to Order By	The figures in the last column refer only to the plates illustrating the parts and are not to be used in ordering. Prices furnished on application.	Plate No.
51290 L	Main Shaft Bushing, outer right, for Styles 51200 K, 51200 L, 51200 M, 51200 N, 51200 R, 51200 S, 51200 T, 51400 P, 51400 Q, 51400 R, 51400 S, 51400 T, 51400 U, 51400 V, 51400 W, 51400 X, 51400 Y, 51400 AA, 51400 AB, 51700 J, 51700 K, 51700 L, 51700 M, 51700 N, 51700 P, 51700 Q, 51700 R, 51700 U - - - -	27
51290 M	Main Shaft Bushing, inner, right, for Styles 51700 M, 51700 N, 51700 U - - - -	27
*51290 N	Main Shaft Bushing Housing, includes bushing, for Styles 51200 A, 51200 B, 51200 C, 51200 D, 51200 G, 51200 H, 51200 J, 51200 U, 51200 V, 51400 A, 51400 B, 51400 C, 51400 D, 51400 E, 51400 F, 51400 G, 51400 H, 51400 J, 51400 K, 51400 M, 51400 N, 51400 AC, 51600 A, 51700 C, 51700 D, 51700 E, 51700 F, 51700 G, 51700 H, 51700 T - - - -	56
*51290 P	Main Shaft Bushing Housing, includes bushing, for Styles 51200 K, 51200 L, 51200 M, 51200 N, 51200 R, 51200 S, 51200 T, 51400 P, 51400 Q, 51400 R, 51400 S, 51400 T, 51400 U, 51400 V, 51400 W, 51400 X, 51400 Y, 51400 AA, 51400 AB, 51700 J, 51700 K, 51700 L, 51700 M, 51700 N, 51700 P, 51700 Q, 51700 R, 51700 U - - - -	56
51291	Main Shaft Bushing Housing Screws No. 22569 B Looper Thread Guard, for Style 51400 G (screw No. 22711) - - - -	48
51292	Tension Post - - - -	18
51292 A	Tension Post Ferrule - - - -	18
51292 C	Tension Post Regulating Nut - - - -	25
51292 D	Thread Tension Eyelet (insert, No. 668-7, insert ferrule No. 668-12) - - - -	18
51292 E	Looper Thread Tension Eyelet, for Style 51400 G (insert No. 668-7, insert Ferrule No. 668-12) - - - -	18
51292 F-1	Tension Spring, .016 inch diameter wire, for looper threads - - - -	32
51292 F-2	Tension Spring, .022 inch diameter wire, for looper threads - - - -	32
51292 F-4	Tension Spring, .026 inch diameter wire, for needle threads - - - -	32
51292 F-5	Tension Spring, .031 inch diameter wire, for needle threads - - - -	32
51292 F-8	Tension Spring, .037 inch diameter wire, for needle threads - - - -	32

LIST OF PARTS

Symbol to Order By	The figures in the last column refer only to the plates illustrating the parts and are not to be used in ordering. Prices furnished on application.	Plate No.
51293 A	Crank Chamber Oil Tube, for outer right main shaft bearing on Styles 51200 A, 51200 B, 51200 C, 51200 D, 51200 G, 51200 H, 51200 J, 51200 U, 51200 V, 51400 A, 51400 B, 51400 C, 51400 D, 51400 E, 51400 F, 51400 G, 51400 H, 51400 J, 51400 K, 51400 M, 51400 N, 51400 AC, 51600 A, 51700 C, 51700 D, 51700 E, 51700 F, 51700 G, 51700 H, 51700 T - - - - -	47
51293 B	Crank Chamber Oil Tube Clamp, for Styles 51200 A, 51200 B, 51200 C, 51200 D, 51200 G, 51200 H, 51200 J, 51200 U, 51200 V, 51400 A, 51400 B, 51400 C, 51400 D, 51400 E, 51400 F, 51400 G, 51400 H, 51400 J, 51400 K, 51400 M, 51400 N, 51400 AC, 51600 A, 51700 C, 51700 D, 51700 E, 51700 F, 51700 G, 51700 H, 51700 T (screw No. 22769) - - - - -	31
51293 K	Crank Chamber Oil Tube, for inner left main shaft bearing on Styles 51700 C, 51700 D, 51700 E, 51700 G, 51700 H - - - - -	46
51293 L	Main Shaft Bearing Oil Tube, for Style 51400 G - - - - -	46
51293 M	Looper Rocker Stud Oil Tube, for Styles 51200 K, 51200 L, 51200 M, 51200 N, 51200 R, 51200 S, 51200 T, 51400 P, 51400 Q, 51400 R, 51400 S, 51400 T, 51400 U, 51400 V, 51400 W, 51400 X, 51400 Y, 51400 AA, 51400 AB (screw No. 22829, coupling No. 61294 X) - - - - -	46
51293 N	Looper Rocker Stud Oil Tube, for Styles 51700 J, 51700 K, 51700 L, 51700 M, 51700 N, 51700 P, 51700 Q, 51700 R, 51700 U (screw No. 22829, coupling No. 61294 X) - - - - -	47
51293 P	Feed Rocker, Feed Lift Eccentric and Looper Avoid Eccentric Oil Tube, for Styles 51200 K, 51200 L, 51200 M, 51200 N, 51200 R, 51200 S, 51200 T, 51400 P, 51400 Q, 51400 R, 51400 S, 51400 T, 51400 U, 51400 V, 51400 W, 51400 X, 51400 Y, 51400 AA, 51400 AB (plug screw No. 88 A, coupling No. 61294 X) - - - - -	46
51293 Q	Left Main Shaft Bearing Oil Tube for Styles 51200 K, 51200 L, 51200 M, 51200 N, 51200 R, 51200 S, 51200 T, 51400 P, 51400 Q, 51400 R, 51400 S, 51400 T, 51400 U, 51400 V, 51400 W, 51400 X, 51400 Y, 51400 AA, 51400 AB, 51700 J, 51700 K, 51700 L, 51700 M, 51700 N, 51700 P, 51700 Q, 51700 R, 51700 U (plug screw No. 88 A, coupling No. 61294 X) - - - - -	46
51293 R	Feed Rocker, Feed Lift Eccentric and Looper Avoid Eccentric Oil Tube, for Styles 51700 J, 51700 K, 51700 L, 51700 M, 51700 N, 51700 P, 51700 Q, 51700 R, 51700 U (plug screw No. 88 A, coupling No. 61294 X) - - - - -	47

LIST OF PARTS

Symbol to Order By	The figures in the last column refer only to the plates illustrating the parts and are not to be used in ordering. Prices furnished on application.	Plate No.
51294 A	Oil Drain Clamp Spring- - - - -	53
51294 F	Oil Tube Coupling, for attaching oil tubes to oil reservoir on Styles 51200 K, 51200 L, 51200 M, 51200 N, 51200 R, 51200 S, 51200 T, 51400 P, 51400 Q, 51400 R, 51400 S, 51400 T, 51400 U, 51400 V, 51400 W, 51400 X, 51400 Y, 51400 AA, 51400 AB, 51700 J, 51700 K, 51700 L, 51700 M, 51700 N, 51700 P, 51700 Q, 51700 R, 51700 U- - - - -	19
51294 G	Main Oil Reservoir, for Styles 51200 U, 51200 V (screw No. 93)- - - - -	61
51295	Isolated Insulators, for "II" installation- - - - -	29
51296	Machine Base Dowel Pin, front and rear left - - - - -	29
51296 A	" " " " rear right- - - - -	29
51301 A	Cloth Plate, for Styles 51200 C, 51200 G, 51200 H, 51200 J, 51400 H, 51400 J, 51600 A (screw No. 80) - - - - -	60
51301 B	Cloth Plate, for Styles 51200 M, 51200 R, 51200 S, 51200 T, 51400 V, 51400 W (screw, 33/64 inch long, No. 80, screw, 21/32 inch long, No. 22574)- - - - -	60
51321 A	Pulley, grooved for round belt, working diameter 2 1/2 inches, for Styles 51200 B, 51200 C, 51200 J, 51200 U, 51200 V, 51400 A, 51400 B, 51400 C, 51400 D, 51400 E, 51400 F, 51400 G, 51400 H, 51400 J, 51400 K, 51400 M, 51400 N, 51400 AC, 51600 A, 51700 C, 51700 D, 51700 E, 51700 F, 51700 G, 51700 H, 51700 M, 51700 T, 51700 U (spot screw No. 22597, set screw No. 22597 A) - - - - -	43
51321 B	Pulley, grooved for No. 2 "V" Belt (spot screw No. 22597, set screw No. 22597 A) - - - - -	43
51401 C	Puller Cloth Plate, for Style 51400 G (screw No. 22839)- - - - -	56
51401 D	Cloth Plate, for Styles 51400 A, 51400 E, 51400 K (screw No. 80)- - - - -	60
51401 H	Cloth Plate, for Style 51400 G (screw No. 80) - - - - -	60
51402	Cloth Plate Slide, front, for Styles 51400 A, 51400 E, 51400 K (cloth plate slide spring No. 380, cloth plate slide spring screw No. 357) - - - - -	56
51404	Parallel Take-up Cast-off, for Style 51400 G (screw No. 22833) - - - - -	19
51405-16	Feed Dog, for Nos. 16 and 18 gauge Styles 51400 A, 51400 P- - - - -	8
51405 A-8	Feed Dog, for Nos. 6 and 8 gauge Styles 51400 A, 51400 P- - - - -	7
51405 A-10	Feed Dog, for Nos. 10 and 12 gauge Styles 51400 A, 51400 P- - - - -	7
51405B-32	Feed Dog, for No. 32 gauge Styles 51400 D, 51400 S - - - - -	8

LIST OF PARTS

Symbol to Order By	The figures in the last column refer only to the plates illustrating the parts and are not to be used in ordering. Prices furnished on application.	Plate No.
51405 B-48	Feed Dog, for No. 48 gauge Styles 51400 B, 51400 Q, 51400 S- - - - -	9
51405 C-48	Feed Dog, for No. 48 gauge Styles 51400 C, 51400 M, 51400 N, 51400 R, 51400 AA, 51400 AB- - - - -	9
51405 E-8	Feed Dog, for Nos. 8, 10 and 12 gauge Styles 51400 E, 51400 T- - - - -	8
51405 E-16	Feed Dog, for No. 16 gauge Styles 51400 E, 51400 T- - - - -	8
51405 F-32	Feed Dog, for No. 32 gauge Styles 51400 F, 51400 U, 51400 Y- - - - -	8
51405 K-26	Feed Dog, for Nos. 24 and 26 gauge Styles 51400 K, 51400 X- - - - -	8
51408-6	Feed Dog Screw No. 22528 Looper, front, for No. 6 gauge Styles 51400 A, 51400 P- - - - -	16
51408-8	Looper front, for Nos. 8 gauge Styles 51400 A, 51400 E, 51400 P, 51400 T- - - - -	16
51408-10	Looper, front, for Nos. 10 gauge Styles 51400 A, 51400 E, 51400 P, 51400 T- - - - -	16
51408-12	Looper, front, for No. 12 gauge Styles 51400 A, 51400 E, 51400 P, 51400 T, 51400 AC- - - - -	16
51408-16	Looper, front, for No. 16 gauge Styles 51400 A, 51400 E, 51400 G, 51400 P, 51400 T, 51400 AC- - - - -	16
51408-18	Looper, front, for No. 18 gauge Styles 51400 A, 51400 G, 51400 P- - - - -	16
51408-24	Looper, front, for No. 24 gauge Styles 51400 G, 51400 K, 51400 X- - - - -	16
51408-26	Looper, front, for No. 26 gauge Styles 51400 J, 51400 K, 51400 W, 51400 X- - - - -	16
51408-32	Looper, front, for No. 32 gauge Styles 51400 D, 51400 F, 51400 S, 51400 U, 51400 Y, 51700 L- - - - -	16
51408-40	Looper, front, for No. 40 gauge, Style 51700 L- - - - -	16
51408-48	Looper, front, for No. 48 gauge Styles 51400 B, 51400 C, 51400 D, 51400 M, 51400 N, 51400 Q, 51400 R, 51400 S, 51400 AA, 51400 AB- - - - -	16
51408 A-16	Looper, front, for No. 16 gauge Styles 51400 H, 51400 V- - - - -	16
51409	Looper, for Styles 51200 A, 51200 G, 51200 K, 51200 R; also back looper for Styles 51400 A, 51400 E, 51400 G, 51400 J, 51400 K, 51400 P, 51400 T, 51400 W, 51400 X, 51400 AC- - - - -	16

LIST OF PARTS

Symbol to Order By	The figures in the last column refer only to the plates illustrating the parts and are not to be used in ordering. Prices furnished on application.	Plate No.
51409 B	Looper, back for Styles 51400 B, 51400 C, 51400 D, 51400 F, 51400 M, 51400 N, 51400 Q, 51400 R, 51400 S, 51400 U, 51400 Y, 51400 AA, 51400 AB; also Nos. 32 and 40 gauge Style 51700 L- - - - -	16
51413	Looper Set Screw No. 73 Looper Rocker, marked "C", for Styles 51400 A, 51400 B, 51400 C, 51400 D, 51400 E, 51400 F, 51400 K, 51400 M, 51400 N, 51400 P, 51400 Q, 51400 R, 51400 S, 51400 T, 51400 U, 51400 X, 51400 Y, 51400 AA, 51400 AB, 51400 AC, 51600 A, Nos. 32 and 40 gauge Style 51700 L- - - - -	41
51417-6	Needle Bar, marked "AR-6", for No. 6 gauge Styles 51400 A, 51400 P- - - - -	44
51417-8	Needle Bar, marked "AR-8", for No. 8 gauge Style 51400 A, 51400 E, 51400 P, 51400 T - - -	44
51417-10	Needle Bar, marked "AR-10", for No. 10 gauge Styles 51400 A, 51400 E, 51400 P, 51400 T- - -	44
51417-12	Needle Bar, marked "AR-12", for No. 12 gauge Styles 51400 A, 51400 E, 51400 P, 51400 T, 51400 AC - - - - -	44
51417-16	Needle Bar, marked "AR-16", for No. 16 gauge Styles 51400 A, 51400 E, 51400 P, 51400 T, 51400 AC - - - - -	44
51417-18	Needle Bar, marked "AR-18", for No. 18 gauge Styles 51400 A, 51400 P- - - - -	44
51417 B	Needle Bar, marked "AR-24", for Styles 51400 B, 51400 C, 51400 D, 51400 F, 51400 J, 51400 K, 51400 M, 51400 N, 51400 Q, 51400 R, 51400 S, 51400 U, 51400 W, 51400 X, 51400 Y, 51400 AA, 51400 AB; also for No. 24 gauge Style 51400 G, Nos. 32 and 40 gauge Style 51700 L- - - - -	44
51418-16	Needle Holder, marked "D-16", for Styles 51400 A, 51400 E, 51400 P, 51400 T, 51400 AC, 51600 A; also for No. 16 gauge Styles 51400 G, 51400 H, 51400 V - - - - -	17
51418 B-32	Needle Holder, marked "D-32", for No. 32 gauge Styles 51400 D, 51400 F, 51400 S, 51400 U, 51400 Y, 51700 L- - - - -	17
51418 B-40	Needle Holder, marked "D-40", for No. 40 gauge Style 51700 L- - - - -	17
51418 B-48	Needle Holder, marked "D-48", for No. 48 gauge Styles 51400 B, 51400 C, 51400 D, 51400 M, 51400 N, 51400 Q, 51400 R, 51400 S, 51400 AA, 51400 AB- - - - -	17
51418 K-24	Needle Holder, marked "L-24", for No. 24 gauge Styles 51400 K, 51400 X- - - - -	17

LIST OF PARTS

Symbol to Order By	The figures in the last column refer only to the plates illustrating the parts and are not to be used in ordering. Prices furnished on application.	Plate No.
51418 K-26	Needle Holder, marked "L-26", for No. 26 gauge Style 51400 K, 51400 X- - - - - Needle Holder Spot Screw No. 89 Needle Set Screw No. 98	17
51420-6	Presser Foot Assembly, for No. 6 gauge Styles 51400 A, 51400 P; one each Nos. 51400 A-6, 91, 22799 B, 51430 B - - - - -	11
51420-8	Presser Foot Assembly, for No. 8 gauge Styles 51400 A, 51400 P; one each Nos. 51430 A-8, 91, 22799 B, 51430 B - - - - -	11
51420-10	Presser Foot Assembly, for No. 10 gauge Styles 51400 A, 51400 P; one each Nos. 51430 A-10, 91, 22799 B, 51430 B- - - - -	11
51420-12	Presser Foot Assembly, for No. 12 gauge Styles 51400 A, 51400 P; one each Nos. 51430 A-12, 91, 22799 B, 51430 B- - - - -	11
51420-16	Presser Foot Assembly, for No. 16 gauge Styles 51400 A, 51400 P; one each Nos. 51430 A-16, 91, 22799 B, 51430 B - - - - -	11
51420-18	Presser Foot Assembly, for No. 18 gauge Styles 51400 A, 51400 P; one each nos. 51430 A-18, 91, 22799 B, 51430 B- - - - -	11
51420 C-32	Presser Foot Assembly, for No. 32 gauge Styles 51400 D, 51400 F, 51400 S, 51400 U; one each Nos. 51430 C-32, 77, 91, 22752 B, 22799 D, 51430- - - - -	11
51420 C-48	Presser Foot Assembly, for No. 48 gauge Styles 51400 B, 51400 C, 51400 D, 51400 N, 51400 Q, 51400 R, 51400 S, 51400 AB; one each Nos. 51430 C-48, 77, 91, 22752 B, 22799 D, 51430- - - - -	11
51420 E-8	Presser Foot Assembly, for No. 8 gauge Styles 51400 E, 51400 T; one each Nos. 51430 E-8, 91, 22799 B, 22840 A, 51430 D, 51430 F - - - - -	11
51420 E-10	Presser Foot Assembly, for No. 10 gauge Styles 51400 E, 51400 T; one each Nos. 51430 E-10, 91, 22799 B, 22840 A, 51430 D, 51430 F - - - - -	11
51420 E-12	Presser Foot Assembly, for No. 12 gauge Styles 51400 E, 51400 T; one each Nos. 51430 E-12, 91, 22799 B, 22840 A, 51430 D, 51430 F - - - - -	11
51420 E-16	Presser Foot Assembly, for No. 16 gauge Styles 51400 E, 51400 T; one each Nos. 51430 E-16, 91, 22799 B, 22840 A, 51430 D, 51430 F - - - - -	11
51420 K-26	Presser Foot Assembly, for No. 26 gauge Styles 51400 K, 51400 X; one each Nos. 51430 K-26, 91, 22799 B, 51430 B- - - - -	11
51420 L-32	Presser Foot, for No. 32 gauge Style 51400 Y (set screw No. 88)- - - - -	36

LIST OF PARTS

Symbol to Order By	The figures in the last column refer only to the plates illustrating the parts and are not to be used in ordering. Prices furnished on application.	Plate No.
51420 M-48	Presser Foot Assembly, for No. 48 gauge Styles 51400 M, 51400 AA; one each Nos. 51430 M-48, 97, 605 A, 16194, 51430 G, 51430 N-48; two each Nos. 88, 91 A; three No. 605- - - - -	12
51423	Parallel Take-up, for Style 51400 G- - - - -	39
51423 B	Shielded Disc Take-up, for Styles in Class 51200, Styles 51400 A, 51400 B, 51400 C, 51400 D, 51400 E, 51400 F, 51400 H, 51400 J, 51400 K, 51400 M, 51400 N, 51400 P, 51400 Q, 51400 R, 51400 S, 51400 T, 51400 U, 51400 V, 51400 W, 51400 X, 51400 Y, 51400 AA, 51400 AB, 51400 AC, 51600 A (spot screw No. 22580) -	39
51424-16	Throat Plate, for No. 16 gauge Styles 51400 A, 51400 P - - - - -	3
51424-18	Throat Plate, for No. 18 gauge Styles 51400 A, 51400 P - - - - -	3
51424 A-6	Throat Plate, for No. 6 gauge Styles 51400 A, 51400 P - - - - -	3
51424 A-8	Throat Plate, for No. 8 gauge Styles 51400 A, 51400 P - - - - -	3
51424 A-10	Throat Plate, for No. 10 gauge Styles 51400 A, 51400 P - - - - -	3
51424 A-12	Throat Plate, for Nos. 12 gauge Styles 51400 A, 51400 P - - - - -	3
51424 B-32	Throat Plate, for No. 32 gauge Styles 51400 D, 51400 S - - - - -	5
51424 B-48	Throat Plate, for No. 48 gauge Styles 51400 B, 51400 D, 51400 Q, 51400 S - - - - -	5
51424 C-48	Throat Plate, for No. 48 gauge Styles 51400 C, 51400 M, 51400 N, 51400 R, 51400 AA, 51400 AB - - - - -	4
51424 E-8	Throat Plate, for No. 8 gauge Styles 51400 E, 51400 T- - - - -	4
51424 E-10	Throat Plate, for No. 10 gauge Styles 51400 E, 51400 T - - - - -	4
51424 E-12	Throat Plate, for No. 12 gauge Styles 51400 E, 51400 T - - - - -	4
51424 E-16	Throat Plate, for No. 16 gauge Styles 51400 E, 51400 T - - - - -	4
51424 F-32	Throat Plate, for No. 32 gauge Styles 51400 F, 51400 U, 51400 Y- - - - -	4
51424 K-24	Throat Plate, for No. 24 gauge Styles 51400 K, 51400 X - - - - -	3
51424 K-26	Throat Plate, for No. 26 gauge Styles 51400 K, 51400 X - - - - -	3
	Throat Plate Screw No. 22570	



## LIST OF PARTS

Symbol to Order By	The figures in the last column refer only to the plates illustrating the parts and are not to be used in ordering. Prices furnished on application.	Plate No.
51425	Needle Rear Guard, for Styles 51400 A, 51400 B, 51400 C, 51400 D, 51400 E, 51400 F, 51400 K, 51400 M, 51400 N, 51400 P, 51400 Q, 51400 R, 51400 S, 51400 T, 51400 U, 51400 X, 51400 Y, 51400 AA, 51400 AB, Nos. 32 and 40 gauge Styles 51700 L (screw No. 22585 B, washer No. 39236 A) - - - - -	16
51430	Presser Foot Shank, for Styles 51400 B, 51400 C, 51400 D, 51400 F, 51400 N, 51400 Q, 51400 R, 51400 S, 51400 U, 51400 AB, 51700 C, 51700 D, 51700 J, 51700 K, 51700 Q, 51700 R, (clamp screw No. 91) - - - - -	14
51430 A-6	Presser Foot Bottom, for No. 6 gauge Styles 51400 A, 51400 P - - - - -	13
51430 A-8	Presser Foot Bottom, for No. 8 gauge Styles 51400 A, 51400 P - - - - -	13
51430 A-10	Presser Foot Bottom, for No. 10 gauge Styles 51400 A, 51400 P - - - - -	13
51430 A-12	Presser Foot Bottom, for No. 12 gauge Styles 51400 A, 51400 P - - - - -	13
51430 A-16	Presser Foot Bottom, for No. 16 gauge Styles 51400 A, 51400 P - - - - -	13
51430 A-18	Presser Foot Bottom, for No. 18 gauge Styles 51400 A, 51400 P - - - - -	13
51430 B	Presser Foot Bottom Hinge Screw No. 22799 B Presser Foot Shank, for Styles 51400 A, 51400 K, 51400 P, 51400 X, (clamp screw No. 91) - - - - -	14
51430 C-32	Presser Foot Bottom, for No. 32 gauge Styles 51400 D, 51400 F, 51400 S, 51400 U - - - - -	13
51430 C-48	Presser Foot Bottom, for No. 48 gauge Styles 51400 B, 51400 C, 51400 D, 51400 N, 51400 Q, 51400 R, 51400 S, 51400 AB - - - - - Presser Bottom Hinge Screw No. 22799 D	13
51430 D	Presser Foot Shank, for Styles 51400 E, 51400 T (clamp screw No. 91) - - - - -	14
51430 E-8	Presser Foot Bottom, for No. 8 gauge Styles 51400 E, 51400 T - - - - -	13
51430 E-10	Presser Foot Bottom, for No. 10 gauge Styles 51400 E, 51400 T - - - - -	13
51430 E-12	Presser Foot Bottom, for No. 12 gauge Styles 51400 E, 51400 T - - - - -	13
51430 E-16	Presser Foot Bottom, for No. 16 gauge Styles 51400 E, 51400 T - - - - -	13
51430 F	Presser Foot Bottom Hinge Screw No. 22799 B Presser Foot Regulating Screw Lock Nut, for Styles 51200 B, 51200 C, 51200 L, 51200 M, 51400 E, 51400 T - - - - -	25
51430 G	Presser Foot Shank, for Style 51400 M, 51400 AA (set screw No. 88) - - - - -	14

LIST OF PARTS

Symbol to Order By	The figures in the last column refer only to the plates illustrating the parts and are not to be used in ordering. Prices furnished on application.	Plate No.
51430 K-26	Presser Foot Bottom, for No. 26 gauge Styles 51400 K, 51400 X, (Hinge Screw No. 22799 B) - - - - -	13
51430 M-48	Presser Foot Bottom, for No. 48 gauge Styles 51400 M, 51400 AA- - - - -	13
51430 N-48	Presser Foot Yielding Section, for No. 48 gauge Styles 51400 M, 51400 AA- - - - -	13
*51443 G	Looper Drive Eccentric Guard, for Style 51400 G (screw No. 94)- - - - -	56
51457 A	Cast-off Plate Support, for styles in Class 51400, Nos. 32 and 40 gauge Style 51700 L (screw No. 22528, washer No. 21657 E) - - -	39
51458	Needle Lever Thread Eyelet, for styles in Classes 51400, 51700 (screw No. 22768)- - -	18
51458 A	Needle Bar Thread Eyelet, for styles in Classes 51400, 51700, Style 51600 A (screw No. 22768)- - - - -	18
51459 A	Looper Thread Tension Post Thread Guide, for styles in Class 51700, Styles 51400 A, 51400 B, 51400 C, 51400 D, 51400 E, 51400 F, 51400 H, 51400 J, 51400 K, 51400 M, 51400 N, 51400 P, 51400 Q, 51400 R, 51400 S, 51400 T, 51400 U, 51400 V, 51400 W, 51400 X, 51400 Y, 51400 AA, 51400 AB, 51400 AC, 51600 A - - -	19
51460	Parallel Take-up Thread Eyelet, front, for Style 51400 G (screw No. 87 U)- - - - -	18
51460 A	Parallel Take-up Thread Eyelet, rear, for Style 51400 G (screw No. 87 U)- - - - -	18
51461	Parallel Take-up Flange, left, for Style 51400 G (screw No. 22794 B) - - - - -	42
51461 A	Parallel Take-up Flange right, for Style 51400 G (set screw No. 89, spot screw No. 22764 A)- - - - -	43
51461 B	Parallel Take-up Block, for Style 51400 G - -	31
51461 C	Parallel Take-up Sleeve, for Style 51400 G- -	29
51462	Parallel Take-up Eyelet Stand, for Style 51400 G (screw No. 79)- - - - -	42
51462 A	Parallel Take-up Eyelet Stud, for Style 51400 G - - - - -	24
51462 B	Parallel Take-up Eyelet Support, for Style 51400 G (screw No. 22560 B) - - - - -	19
51462 C	Parallel Take-up Eyelet Stand Pin, for Style 51400 G - - - - -	45
51477	Puller Frame, for Style 51400 G (screw No. 22788)- - - - -	-

LIST OF PARTS

Symbol to Order By	The figures in the last column refer only to the plates illustrating the parts and are not to be used in ordering. Prices furnished on application.	Plate No.
51480	Throat Plate Support, for Styles 51200 A, 51200 B, 51200 D, 51200 K, 51200 L, 51200 N, 51400 A, 51400 B, 51400 C, 51400 D, 51400 E, 51400 F, 51400 K, 51400 M, 51400 N, 51400 P, 51400 Q, 51400 R, 51400 S, 51400 T, 51400 U, 51400 X, 51400 Y, 51400 AA, 51400 AB, 51700 C, 51700 D, 51700 J, 51700 K, 51700 Q, 51700 R, using throat plates 3 1/8 inches long (screw No. 22839)	55
51482 A	Looper Mechanism Guard, for Style 51400 G (screw No. 25 S)	56
51482 B	Cloth Plate End Cover, for Style 51400 G	61
51491	Looper Thread Guide Wire, for Styles 51400 A, 51400 B, 51400 C, 51400 D, 51400 E, 51400 F, 51400 H, 51400 J, 51400 K, 51400 M, 51400 N, 51700 C, 51700 D, 51700 E, 51700 F, 51700 G, 51700 H (screw No. 87 U)	43
51491 B-4	Thread Lead-in Guide, for Styles 51400 A, 51400 B, 51400 C, 51400 D, 51400 E, 51400 F, 51400 H, 51400 J, 51400 M, 51400 N (screw No. 94)	53
51491 C	Lead-in Thread Eyelet, for Styles 51200 K, 51200 L, 51200 M, 51200 N, 51200 R, 51200 S, 51200 T, 51200 U, 51200 V, 51400 P, 51400 Q, 51400 R, 51400 S, 51400 T, 51400 U, 51400 V, 51400 W, 51400 X, 51400 Y, 51400 AA, 51400 AB, 51400 AC, 51600 A, 51700 J, 51700 K, 51700 L, 51700 M, 51700 N, 51700 P, 51700 Q, 51700 R, 51700 T, 51700 U	18
51492	Looper Thread Tension Post, for styles in Classes 51400, 51700	30
51494	Main Oil Reservoir, for Styles 51200 A, 51200 B, 51200 C, 51200 D, 51200 G, 51200 H, 51200 J, 51400 A, 51400 B, 51400 C, 51400 D, 51400 E, 51400 F, 51400 H, 51400 J, 51400 K, 51400 M, 51400 N, 51400 AC, 51600 A (screw No. 93)	61
51513	Looper Rocker, marked "D", for Styles 51400 G, 51400 H, 51400 J, 51400 V, 51400 W	41
51517-16	Needle Bar, marked "AW-16", for No. 16 gauge Styles 51400 G, 51400 H, 51400 V	44
51517 A	Needle Bar, marked "AV", for No. 18 gauge Styles 51400 G, 51400 H, 51400 V Needle Bar Set Screw No. 88 A	44
51525	Needle Rear Guard, for Styles 51400 G, 51400 H, 51400 J, 51400 V, 51400 W (screw No. 22585 B, washer No. 39236 A)	16
51582	Oil Deflector Disc, for Styles 51700 M, 51700 N, 51700 U (set screw No. 98)	28

LIST OF PARTS

Symbol to Order By	The figures in the last column refer only to the plates illustrating the parts and are not to be used in ordering. Prices furnished on application.	Plate No.
51701 C	Cloth Plate, for Styles 51400 B, 51400 C, No. 48 gauge Style 51400 D, Styles 51400 M, 51400 N, 51700 C, 51700 D (screw No. 80) - - - - -	60
51701 F	Cloth Plate, for Style 51700 E (screw No. 80) - - - - -	60
51701 G	Cloth Plate, for Styles 51400 Q, 51400 S, 51400 AA, 51400 AB, 51700 J, 51700 K, 51700 Q, 51700 R (screw 33/64 inch long, No. 80, screw 21/32 inch long, No. 22574) - - - - -	60
51701 P	Cloth Plate, for Styles 51700 N, 51700 P, (screw 33/64 inch long, No. 80, screw 21/32 inch long, No. 22574) - - - - -	60
51704	Cast-off Plate, for Styles in Class 51700 (screw No. 28) - - - - -	39
51705-56	Feed Dog, for No. 56 gauge Styles 51700 C, 51700 J - - - - -	9
51700-64	Feed Dog, for No. 64 gauge Styles 51700 C, 51700 J, 51700 Q - - - - -	9
51705-72	Feed Dog, for No. 72 gauge Styles 51700 C, 51700 J - - - - -	9
51705-80	Feed Dog, for No. 80 gauge - - - - -	9
51705-96	Feed Dog, for No. 96 gauge - - - - -	9
51705-112	Feed Dog, for No. 112 gauge - - - - -	9
51705 D-56	Feed Dog, for No. 56 gauge Styles 51700 D, 51700 K, 51700 R - - - - -	9
51705 D-64	Feed Dog, for No. 64 gauge - - - - -	9
51705 D-72	Feed Dog, for No. 72 gauge - - - - -	9
51705 D-80	Feed Dog, for No. 80 gauge - - - - -	9
51705 D-96	Feed Dog, for No. 96 gauge - - - - -	9
51705 D-112	Feed Dog, for No. 112 gauge - - - - -	9
51705 E-64	Feed Dog, for No. 64 gauge Styles 51700 E, 51700 L - - - - -	9
51705 E-72	Feed Dog, for No. 72 gauge - - - - -	9
51705 E-80	Feed Dog, for No. 80 gauge - - - - -	9
51705 G-128	Feed Dog, for No. 128 gauge Styles 51700 G, 51700 H, 51700 N, 51700 P - - - - -	9
51708	Looper, right, for Styles 51700 C, 51700 D, 51700 E, 51700 F, 51700 G, 51700 H, 51700 J, 51700 K, Nos. 64, 72 and 80 gauge Style 51700 L, Style 51700 M, 51700 N, 51700 P, 51700 Q, 51700 R, 51700 T, 51700 U - - - - -	15
51709	Looper, left, for Styles 51700 C, 51700 D, 51700 E, 51700 F, 51700 G, 51700 H, 51700 J, 51700 K, Nos. 64, 72, and 80 gauge Style 51700 L, Styles 51700 M, 51700 N, 51700 P, 51700 Q, 51700 R, 51700 T, 51700 U - - - - -	16
	Looper Set Screw No. 73	

LIST OF PARTS

Symbol to Order By	The figures in the last column refer only to the plates illustrating the parts and are not to be used in ordering. Prices furnished on application.	Plate No.
51713	Looper Rocker, marked "E", for Styles 51700 C, 51700 D, 51700 E, 51700 F, 51700 G, 51700 H, 51700 J, 51700 K, Nos. 64, 72, and 80 gauge Style 51700 L, Styles 51700 M, 51700 N, 51700 P, 51700 Q, 51700 R, 51700 T, 51700 U- - - -	41
51717	Needle Bar, marked "AU", for Styles 51700 C, 51700 D, 51700 E, 51700 F, 51700 G, 51700 H, 51700 J, 51700 K, Nos. 64, 72, and 80 gauge Style 51700 L, Styles 51700 M, 51700 N, 51700 P, 51700 Q, 51700 R, 51700 T, 51700 U- - - - (set screw No. 88 A)- - - - -	44
51720-56	Presser Foot Assembly, for No. 56 gauge Styles 51700 C, 51700 J; one each Nos. 51730-56, 77, 91, 22752 B, 22799 D, 51430, 51730 A-56; two No. 91 A- - - - -	12
51720-64	Presser Foot Assembly, for No. 64 gauge Styles 51700 C, 51700 J, 51700 Q; one each Nos. 51730-64, 77, 91, 22752 B, 22799 D, 51430, 51730 A-64; two No. 91 A- - - - -	12
51720-72	Presser Foot Assembly, for No. 72 gauge Styles 51700 C, 51700 J; one each Nos. 51730-72, 77, 91, 22752 B, 22799 D, 51430, 51730 A-72; two No. 91 A- - - - -	12
51720-80	Presser Foot Assembly, for No. 80 gauge; one each Nos. 51730-80, 77, 91, 22752 B, 22799 D, 51430, 51730 A-80; two No. 91 A- - - - -	12
51720-96	Presser Foot Assembly, for No. 96 gauge; one each Nos. 51730-96, 77, 91, 22752 B, 22799 D, 51430, 51730 A-96; two No. 91 A- - - - -	12
51720-112	Presser Foot Assembly, for No. 112 gauge; one each Nos. 51730-112, 77, 91, 22752 B, 22799 D, 51430, 51730 A-112; two No. 91 A- - - - -	12
51720 D-56	Presser Foot Assembly, for No. 56 gauge Styles 51700 D, 51700 K, 51700 R; one each Nos. 51730 D-56, 77, 91, 22752 B, 22799 D, 51430- - - - -	11
51720 D-64	Presser Foot Assembly, for No. 64 gauge Styles 51700 D, 51700 K; one each Nos. 51730 D-64, 77, 91, 22752 B, 22799 D, 51430 - - - - -	11
51720 D-72	Presser Foot Assembly, for No. 72 gauge; one each Nos. 51730 D-72, 77, 91, 22752 B, 22799 D, 51430 - - - - -	11
51720 D-80	Presser Foot Assembly, for No. 80 gauge; one each Nos. 51730 D-80, 77, 91 22752 B, 22799 D, 51430 - - - - -	11

LIST OF PARTS

Symbol to Order By	The figures in the last column refer only to the plates illustrating the parts and are not to be used in ordering. Prices furnished on application.	Plate No.
51720 D-96	Presser Foot Assembly, for No. 96 gauge; one each Nos. 51730 D-96, 77, 91, 22752 B, 22799 D, 51430- - - - -	11
51720 D-112	Presser Foot Assembly, for No. 112 gauge; one each Nos. 51730 D-112, 77, 91, 22752 B, 22799 D, 51430- - - - -	11
51720 E-64	Presser Foot Assembly, for No. 64 gauge Styles 51700 E, 51700 L; one each Nos. 51730 E-64, 605, 1740, 8040, 51730 F-64; two No. 88; three No. 605 A- - - - -	13
51720 E-72	Presser Foot Assembly, for No. 72 gauge; one each Nos. 51730 E-72, 605, 1740, 8040, 51730 F-72; two No. 88; three No. 605 A- - - - -	13
51720 E-80	Presser Foot Assembly, for No. 80 gauge; one each Nos. 51730 E-80, 605, 1740, 8040, 51730 F-80; two No. 88; three No. 605 A- - - - -	13
51722	Main Shaft, left section, for Styles 51700 C, 51700 D, 51700 E, 51700 F, 51700 G, 51700 H, 51700 J, 51700 K, Nos. 64, 72, and 80 gauge Style 51700 L, Styles 51700 M, 51700 N, 51700 P, 51700 Q, 51700 R, 51700 T, 51700 U- - - - -	57
51723 A	Shielded Disc Take-up, for Styles 51700 C, 51700 D, 51700 E, 51700 F, 51700 G, 51700 H, 51700 J, 51700 K, Nos. 64, 72, and 80 gauge Style 51700 L; Styles 51700 M, 51700 N, 51700 P, 51700 Q, 51700 R, 51700 T, 51700 U (set screw No. 22580, spot screw No. 96)- - - - -	39
51724-56	Throat Plate, for No. 56 gauge Styles 51700 C, 51700 J - - - - -	5
51724-64	" " for No. 64 gauge Styles 51700 C, 51700 J 51700 Q- - -	5
51724-72	" " for No. 72 gauge Styles 51700 C, 51700 J - - - - -	5
51724-80	" " for No. 80 gauge - - - - -	5
51724-96	" " for No. 96 gauge - - - - -	5
51724-112	" " for No. 112 gauge- - - - -	5
51724 D-56	" " for No. 56 gauge Styles 51700 D, 51700 K - - - - -	5
51724 D-64	" " for No. 64 gauge - - - - -	5
51724 D-72	" " for No. 72 gauge - - - - -	5
51724 D-80	" " for No. 80 gauge - - - - -	5
51724 D-96	" " for No. 96 gauge - - - - -	5
51724 D-112	" " for No. 112 gauge- - - - -	5
51724 E-64	" " for No. 64 gauge Styles 51700 E, 51700 L - - - - -	6
51724 E-72	" " for No. 72 gauge - - - - -	6
51724 E-80	" " for No. 80 gauge - - - - -	6
	Throat Plate Screw No. 22570	

LIST OF PARTS

Symbol to Order By	The figures in the last column refer only to the plates illustrating the parts and are not to be used in ordering. Prices furnished on application.	Plate No.
51724 G-128	Throat Plate, for No. 128 gauge Styles 51700 G, 51700 H, 51700 N, 51700 P (screw No. 87) - - - - -	2
51725	Needle Rear Guard, for Nos. 56 to 96 gauge Styles 51700 C, 51700 D, 51700 F, 51700 J, 51700 K, 51700 M, 51700 Q, 51700 R - - - - -	17
51725 A	Needle Rear Guard, for Nos. 96 to 112 gauge Styles 51700 C, 51700 D, 51700 J, 51700 K, 51700 T, 51700 U - - - - -	17
51725 E	Needle Rear Guard, for Styles 51700 E, 51700 L - - - - -	16
51730-56	Needle Rear Guard Screw No. 22585 B Needle Rear Guard Washer No. 39236 A Presser Foot Bottom, for No. 56 gauge Styles 51700 C, 51700 J - - - - -	14
51730-64	Presser Foot Bottom, for No. 64 gauge Styles 51700 C, 51700 J, 51700 Q - - - - -	14
51730-72	Presser Foot Bottom, for No. 72 gauge Styles 51700 C, 51700 J - - - - -	14
51730-80	Presser Foot Bottom, for No. 80 gauge - - - - -	14
51730-96	Presser Foot Bottom, for No. 96 gauge - - - - -	14
51730-112	Presser Foot Bottom, for No. 112 gauge - - - - -	14
51730 A-56	Presser Foot Bottom Hinge Screw No. 22799 D Presser Foot Flexible Toe, for No. 56 gauge Styles 51700 C, 51700 J - - - - -	15
51730 A-64	Presser Foot Flexible Toe, for No. 64 gauge Styles 51700 C, 51700 J, 51700 Q - - - - -	15
51730 A-72	Presser Foot Flexible Toe, for No. 72 gauge Styles 51700 C, 51700 J - - - - -	15
51730 A-80	Presser Foot Flexible Toe, for No. 80 gauge - - - - -	15
51730 A-96	Presser Foot Flexible Toe, for No. 96 gauge	15
51730 A-112	Presser Foot Flexible Toe for No. 112 gauge	15
51730 D-56	Presser Foot Flexible Toe Screw No. 91 A Presser Foot Bottom, for No. 56 gauge Styles 51700 D, 51700 K, 51700 R - - - - -	13
51730 D-64	Presser Foot Bottom, for No. 64 gauge - - - - -	13
51730 D-72	" " " for No. 72 gauge - - - - -	13
51730 D-80	" " " for No. 80 gauge - - - - -	13
51730 D-96	" " " for No. 96 gauge - - - - -	13
51730 D-112	" " " for No. 112 gauge - - - - -	13
51730 E-64	Presser Foot Bottom Hinge Screw No. 22799 D Presser Foot Bottom, for No. 64 gauge Styles 51700 E, 51700 L - - - - -	14
51730 E-72	" " " for No. 72 gauge - - - - -	14
51730 E-80	" " " for No. 80 gauge - - - - -	14
51730 F-72	" " Yielding Section, for No. 72 gauge Styles 51700 E, 51700 L - - - - -	13
51730 F-80	Presser Foot Yielding Section, for Nos. 64 and 80 gauge Styles 51700 E, 51700 L - - - - -	13

LIST OF PARTS

Symbol to Order By	The figures in the last column refer only to the plates illustrating the parts and are not to be used in ordering. Prices furnished on application.	Plate No.
51741	Looper Connecting Rod Ball Joint, left, for Styles 51700 C, 51700 D, 51700 E, 51700 F, 51700 G, 51700 H, 51700 J, 51700 K, Nos. 64, 72, and 80 gauge Style 51700 L, Style 51700 M, 51700 N, 51700 P, 51700 Q, 51700 R, 51700 T, 51700 U, equipped with looper drive levers Nos. 51242 E, 51242 J, 51242 T, 51242 V (bearing screw No. 97 A) - - - - -	29
51741 B	Looper Connecting Rod Ball Joint, right, for Styles 51700 C, 51700 D, 51700 E, 51700 F, 51700 G, 51700 H, 51700 J, 51700 K, Nos. 64, 72 and 80 gauge Style 51700 L, Style 51700 M, 51700 N, 51700 P, 51700 Q, 51700 R, 51700 T, 51700 U, equipped with Looper drive levers Nos. 51242 E, 51242 J, 51242 T, 51242 V (ball stud washer No. 36 G, bearing screw No. 97 A) - - - - -	29
51741 C	Looper Connecting Rod Ball Joint, right, with .232 inch diameter shoulder on ball stud, for Styles 51700 C, 51700 D, 51700 E, 51700 F, 51700 G, 51700 H, 51700 J, 51700 K, Nos. 64, 72, and 80 gauge Style 51700 L, Styles 51700 M, 51700 N, 51700 P, 51700 Q, 51700 R, 51700 T, 51700 U equip- ped with looper drive levers Nos. 51242 N, 51242 U (ball stud washer No. 51741 E, bearing screw No. 97 A) - - - - -	29
51741 E	Looper Connecting Rod Ball Stud Washer, for machines equipped with looper drive levers Nos. 51242 N, 51242 U - - - - -	26
51743 B	Main Oil Reservoir, for Styles 51700 C, 51700 D, 51700 E, 51700 H (screw No. 93) - - - - -	61
51743 F	Main Oil Reservoir, for Styles 51700 F, 51700 G, 51700 T (screw No. 93) - - - - -	61
51743 G	Oil Line "L" Coupling, for inner right main shaft bearing on Styles 51700 F, 51700 G, 51700 T - - - - -	47
51744 A	Looper Rocker Frame, for Styles 51700 C, 51700 D, 51700 E, 51700 F, 51700 G, 51700 H, 51700 J, 51700 K, Nos. 64, 72, 80 gauge Styles 51700 L, Styles 51700 M, 51700 N, 51700 P, 51700 R, 51700 T, 51700 U (spot screw No. 96, set screw No. 98) - - - - -	41
51745	Looper Rocker Cone Stud - - - - -	30



LIST OF PARTS

Symbol to Order By	The figures in the last column refer only to the plates illustrating the parts and are not to be used in ordering. Prices furnished on application.	Plate No.
51751	Presser Bar Guide, for Styles 51200 K, 51200 L, 51200 M, 51200 N, 51200 R, 51200 S, 51200 T, 51400 P, 51400 Q, 51400 R, 51400 S, 51400 T, 51400 U, 51400 V, 51400 W, 51400 X, 51400 Y, 51400 AA, 51400 AB, 51700 J, 51700 K, 51700 L, 51700 M, 51700 N, 51700 P, 51700 Q, 51700 R, 51700 U (screw No. 22560 B) - - - -	28
51757 A	Cast-off Plate Support, for Styles 51700 C, 51700 D, 51700 E, 51700 F, 51700 G, 51700 H, 51700 J, 51700 K, Nos. 64, 72, 80 gauge Style 51700 L, Style 51700 M, 51700 N, 51700 P, 51700 Q, 51700 R, 51700 T, 51700 U (screw No. 22528, washer No. 21657 E) - - - -	39
51758	Frame Needle Thread Eyelet, intermediate, (attaching screw No. 22848, adapter screw No. 22840, washer No. 20) - - - -	18
51758 A	Frame Needle Thread Guide, for Styles in Class 51700; Styles 51200 A, 51200 D, 51200 G, 51200 H, 51200 K, 51200 L, 51200 M, 51200 N, 51200 R, 51200 S, 51200 T, 51400 A, 51400 B, 51400 C, 51400 D, 51400 E, 51400 F, 51400 H, 51400 J, 51400 K, 51400 M, 51400 N, 51400 P, 51400 Q, 51400 R, 51400 S, 51400 T, 51400 U, 51400 V, 51400 W, 51400 X, 51400 Y, 51400 AA, 51400 AB (screw No. 22730) - - - -	17
51759 A	Feed Bar Thread Eyelet, for Nos. 72, 80 gauge Styles 51700 L, Styles 51700 P, 51700 T, 51700 U (screw No. 90) - - - -	17
51770-56	Looper Rocker Link, for No. 56 gauge styles in Class 51700 - - - -	28
51770-64	Looper Rocker Link, for No. 64 gauge - - - -	28
51770-72	" " " for No. 72 gauge - - - -	28
51770-80	" " " for No. 80 gauge - - - -	28
51770-88	" " " for No. 88 gauge - - - -	28
51770-96	" " " for No. 96 gauge - - - -	28
51770-112	" " " for No. 112 gauge - - - -	28
51770-128	" " " for No. 128 gauge - - - -	28
51771	Looper Rocker Link Screw No. 22835 Looper Rocker Link Bushing, for Styles 51700 C, 51700 D, 51700 E, 51700 F, 51700 G, 51700 H, 51700 J, 51700 K, Nos. 64, 72, 80 gauge Styles 51700 L, 51700 M, 51700 N, 51700 P, 51700 Q, 51700 R, 51700 T, 51700 U - - - -	26
51772-56	Looper Rocker Spacing Plate, for Nos. 56 and 96 gauge styles in Class 51700 - - - -	41
51772-64	Looper Rocker Spacing Plate, for Nos. 64 and 104 gauges - - - -	41

LIST OF PARTS

Symbol to Order By	The figures in the last column refer only to the plates illustrating the parts and are not to be used in ordering. Prices furnished on application.	Plate No.
51772-72	Looper Rocker Spacing Plate, for Nos. 72 and 112 gauge- - - - -	41
51772-80	Looper Rocker Spacing Plate, for No. 80 gauge-	41
51772-88	Looper Rocker Spacing Plate, for Nos. 88 and 128 gauge- - - - -	41
51773	Looper Rocker Frame Spacing Collar, for Styles 51700 C, 51700 D, 51700 E, 51700 F, 51700 G, 51700 H, 51700 J, 51700 K, Nos. 64, 72, 80 gauge Style 51700 L, Style 51700 M, 51700 N, 51700 P, 51700 Q, 51700 R, 51700 T, 51700 U (screw No. 88 B)- - - - -	26
51774-64	Differential Feed Roll, upper, for No. 64 gauge Styles 51700 E, 51700 L- - - - -	38
51774-72	Differential Feed Roll, upper, for No. 72 gauge- - - - -	38
51774-80	Differential Feed Roll, upper, for No. 80 gauge- - - - -	38
51774 D	Differential Feed Roll Screw No. 22743 Differential Feed Roll Shaft, for Nos. 64, 72, and 80 gauge Styles 51700 E, 51700 L- - - - -	15
51774 H	Differential Feed Roll Link, for Styles 51700 E, 51700 L- - - - -	28
51774 L	Differential Feed Roll Yoke for Nos. 64, 72, and 80 gauge Styles 51700 E, 51700 L (screw No. 88)- - - - -	38
51774 N	Differential Feed Roll Yoke Support for Styles 51700 E, 51700 L (attaching screw No. 22581, stop screw No. 22797)- - - - -	38
51774 P	Differential Feed Roll Yoke Support Bracket for Nos. 64, 72, and 80 gauge Styles 51700 E, 51700 L (attaching screw No. 93)- - - - -	37
51774 T	Differential Feed Roll Yoke Spring for Styles 51700 E, 51700 L (attaching screw No. 605 A)- - - - -	32
51775	Differential Feed Intermediate Gear, for Styles 51700 E, 51700 L- - - - -	28
51775 A	Differential Feed Intermediate Gear Guard for Styles 51700 E, 51700 L (screw No. 604)- - - - -	49
51776	Differential Feed Roll, lower, for Nos. 64, 72, and 80 gauge Styles 51700 E, 51700 L (screw No. 22565 C)- - - - -	38
51777-72	Stripper Blade, for Nos. 64 and 72 gauge Styles 51700 E, 51700 L (screw No. 22726 A)- - - - -	37
51777-80	Stripper Blade, for No. 80 gauge (screw No. 22726 A)- - - - -	37
51777 D	Lower Roll Shaft and Driving Pinion, Nos. 64, 72, and 80 gauge Styles 51700 E, 51700 L- - - - -	15
51777 H	Lower Roll Link, for Styles 51700 E, 51700 L- - - - -	28
51777 L	Lower Roll Bracket for Nos. 64, 72, and 80 gauge Styles 51700 E, 51700 L (attaching screw No. 87)- - - - -	38

LIST OF PARTS

Symbol to Order By	The figures in the last column refer only to the plates illustrating the parts and are not to be used in ordering. Prices furnished on application.	Plate No.
51780 A	Throat Plate Support, for Styles 51700 F, 51700 G, 51700 H, 51700 J, 51700 K, Nos. 64, 72, and 80 gauge Style 51700 L, Styles 51700 N, 51700 P, 51700 Q, 51700 R, 51700 T, 51700 U (screw No. 80) - - - - -	55
51782	Oil Wicking Guard, for Styles 51700 J, 51700 K, Nos. 64, 72, and 80 gauge Styles 51700 L, Styles 51700 M, 51700 N, 51700 P, 51700 Q, 51700 R (screw No. 25 S) - - - - -	47
51785	Spring, .024 inch diameter wire, for guide leading strip to feed dog on Styles 51700 E, 51700 L (screw No. 22504, washer No. 8372 A - - - - -	32
51909 B	Looper, for Styles 51200 B, 51200 L (set screw No. 73) - - - - -	16
51959	Looper Thread Nipper Support, for Style 51400 G (screw No. 93 A) - - - - -	19
51959 B	Looper Thread Nipper Disc - - - - -	18
51959 C	Looper Thread Nipper Spring, for Styles in Class 51200, Style 51400 G - - - - -	32
51959 D	Looper Thread Nipper Nut - - - - -	25
51959 E	Looper Thread Nipper Stud Spacing Collar, for styles in Class 51200, Styles 51400 G, 51400 AC, 51600 A - - - - -	26
51991	Looper Thread Guard, for styles in Classes 51200, 51700, Styles 51400 A, 51400 B, 51400 C, 51400 D, 51400 E, 51400 F, 51400 H, 51400 J, 51400 K, 51400 M, 51400 N, 51400 P, 51400 Q, 51400 R, 51400 S, 51400 T, 51400 U, 51400 V, 51400 W, 51400 X, 51400 Y, 51400 AA, 51400 AB, 51400 AC, 51600 A (screw No. 93 A) - - - - -	48
K52033	Presser Foot, for No. 24 gauge Styles 51400 K, 51400 X (presser foot shank No. 51430 B, hinge screw No. 22799 B, clamp screw No. 91) - - - - -	11
52782 H	Crank Shaft Chamber Cover Oil Catch Plate, for Styles 51200 U, 51200 V, 51400 G, 51400 AC, 51600 A, 51700 T (screw No. 187 A) - - - - -	47
52795	Main Shaft Oil Gauge Assembly, for Styles 51200 A, 51200 B, 51200 C, 51200 D, 51200 G, 51200 H, 51200 J, 51200 U, 51200 V, 51400 A, 51400 B, 51400 C, 51400 D, 51400 E, 51400 F, 51400 G, 51400 H, 51400 J, 51400 K, 51400 M, 51400 N, 51400 AC, 51600 A, 51700 C, 51700 D, 51700 E, 51700 F, 51700 G, 51700 H, 51700 T; one each Nos. 52895 G, 660-92, 660-93, 660-94, 660-95 - - - - -	47

LIST OF PARTS

Symbol to Order By	The figures in the last column refer only to the plates illustrating the parts and are not to be used in ordering. Prices furnished on application.	Plate No.
52802 A	Cloth Plate Slide, rear, 1 3/4 inches long, for Styles 51200 U, 51200 V (stop screw No. 22799 N) - - - - -	49
52804	Cast-off Plate, for Styles 51200 U, 51200 V (screw No. 28) - - - - -	39
52804 A	Cast-off Plate, for Styles 51200 A, 51200 B, 51200 C, 51200 D, 51200 G, 51200 H, 51200 J, 51200 K, 51200 L, 51200 M, 51200 N, 51200 R, 51200 S, 51200 T, 51400 A, 51400 B, 51400 C, 51400 D, 51400 E, 51400 F, 51400 H, 51400 J, 51400 K, 51400 M, 51400 N, 51400 P, 51400 Q, 51400 R, 51400 S, 51400 T, 51400 U, 51400 V, 51400 W, 51400 X, 51400 Y, 51400 AA, 51400 AB (screw No. 28) - - - - -	39
52834	Main Feed Bar, for Styles 51200 V, 51400 AC, 51600 A (set screw No. 22560 B) - - - - -	42
52834 G	Differential Feed Bar, for Styles 51200 V, 51400 AC, 51600 A - - - - -	45
52834 N	Looper Drive Ball Joint Locking Stud Nut - - - - -	25
52835	Differential Feed Control Lever, front, for Styles 51400 AC, 51600 A (lock nut No. 9937) -	42
52835 D	Differential Feed Control Lever, rear, for Styles 51200 V, 51400 AC, 51600 A (screw No. 22758 B, nut No. 12934 A) - - - - -	42
52835 G	Differential Feed Control Link, for Styles 51200 V, 51400 AC, 51600 A (screw No. 22758 B, nut No. 12934 A) - - - - -	28
52835 K	Differential Feed Control Lever Spring, for Styles 51200 V, 51400 AC 51600 A - - - - -	32
52835 N	Differential Feed Regulating Segment Plate, for Styles 51400 AC, 51600 A (screw No. 22848)	42
52835 Q	Differential Feed Fork, for Styles 51200 V, 51400 AC, 51600 A - - - - -	31
52835 S	Differential Feed Fork Block, for Styles 51200 V, 51400 AC, 51600 A (stud No. 22868 A)	30
52835 U	Differential Feed Control Link Pivot Stud Insert, for Styles 51200 V, 51400 AC, 51600 A (set screw No. 22597, plug screw No. 719) - - - - -	26
52835 W	Differential Feed Control Lever Bushing, for Styles 51200 V, 51400 AC, 51600 A (set screw No. 22597) - - - - -	27
52836	Feed Rocker, for Styles 51200 V, 51400 AC, 51600 A (screw No. 89) - - - - -	42
52836 C	Feed Rocker Arm, for Styles 51200 V, 51400 AC, 51600 A (clamp screw No. 22519 C) - - - - -	41
52836 H	Feed Rocker Segment Slot Plate, for Styles 51200 V, 51400 AC, 51600 A (screw No. 22516)	42
52841	Looper Drive Ball Joint Locking Stud (washer No. 8372 A, lock nut No. 52834 N) - - - - -	29
52857 B	Cast-off Wire Support, for styles in Class 51200 (screw No. 22528, washer 21657 E) - - -	39

LIST OF PARTS

Symbol to Order By	The figures in the last column refer only to the plates illustrating the parts and are not to be used in ordering. Prices furnished on application.	Plate No.
52864 B	Cloth Plate Swinging Arm Platform, for Style 51200 U (screw No. 94) - - - - -	56
52864 E	Cloth Plate Swinging Arm Platform, for Style 51200 V (screw No. 90) - - - - -	49
52864 G	Cloth Plate Swinging Arm Base, for Styles 51200 U, 51200 V (screw No. 79) - - - - -	42
52864 N	Folder Support Bracket, for Style 51200 V (screw No. 22567) - - - - -	36
52880	Throat Plate Support, for Styles 51200 U, 51200 V (screw No. 22574) - - - - -	55
52882 B	Crank Chamber Cover, rear, for Styles 51200 A, 51200 B, 51200 C, 51200 D, 51200 G, 51200 H, 51200 J, 51200 U, 51200 V, 51400 A, 51400 B, 51400 C, 51400 D, 51400 E, 51400 F, 51400 G, 51400 H, 51400 J, 51400 K, 51400 M, 51400 N, 51400 AC, 51600 A, 51700 C, 51700 D, 51700 E, 51700 F, 51700 G, 51700 H, 51700 T (screw No. 90) - - - - -	49
52882 D	Crank Chamber Oil Reservoir Cover Assembly, for Styles 51200 A, 51200 B, 51200 C, 51200 D, 51200 G, 51200 H, 51200 J, 51200 U, 51200 V, 51400 A, 51400 B, 51400 C, 51400 D, 51400 E, 51400 F, 51400 G, 51400 H, 51400 J, 51400 K, 51400 M, 51400 N, 51400 AC, 51600 A, 51700 C, 51700 D, 51700 E, 51700 F, 51700 G, 51700 H, 51700 T; one each Nos. 666-50, 35788 B (screw No. 605) - - - - -	47
52882 E	Crank Chamber Oil Reservoir Gasket, for Styles 51200 A, 51200 B, 51200 C, 51200 D, 51200 G, 51200 H, 51200 J, 51200 U, 51200 V, 51400 A, 51400 B, 51400 C, 51400 D, 51400 E, 51400 F, 51400 G, 51400 H, 51400 J, 51400 K, 51400 M, 51400 N, 51400 AC, 51600 A, 51700 C, 51700 D, 51700 E, 51700 F, 51700 G, 51700 H, 51700 T -	56
52883	Lifter Lever, for Styles 51200 U, 51200 V, 51400 G, 51400 AC, 51600 A, 51700 T (stud No. 22566 C) - - - - -	61
52883 G	Presser Bar Lifter Bracket and Guide, for Styles 51200 A, 51200 B, 51200 C, 51200 D, 51200 G, 51200 H, 51200 J, 51200 U, 51200 V, 51400 A, 51400 B, 51400 C, 51400 D, 51400 E, 51400 F, 51400 G, 51400 H, 51400 J, 51400 K, 51400 M, 51400 N, 51400 AC, 51600 A, 51700 C, 51700 D, 51700 E, 51700 F, 51700 G, 51700 H, 51700 T (screw No. 89) - - - - -	39
52885 A	Cloth Plate End Cover, for Style 51200 U - - -	61
52885 G	Cloth Plate End Cover Hinge, front, including pin, for Styles 51200 U, 51200 V, 51400 G (screw No. 22848) - - - - -	30
52885 H	Cloth Plate End Cover Hinge, rear, including pin, for Styles 51200 U, 51200 V, 51400 G, (screw No. 22848) - - - - -	30

LIST OF PARTS

Symbol to Order By	The figures in the last column refer only to the plates illustrating the parts and are not to be used in ordering. Prices furnished on application.	Plate No.
52887	Presser Spring (locating screw No. 35768 A) - -	39
52887 G	Presser Spring Rest - - - - -	31
52887 N	Presser Spring Regulating Stud (nut No. 258 A)	30
52888	Presser Bar - - - - -	44
52889	Presser Bar Bushing, upper - - - - -	27
52894 G	Main Oil Reservoir Cover, for Styles 51200 A, 51200 B, 51200 C, 51200 D, 51200 G, 51200 H, 51200 J, 51200 U, 51200 V, 51400 A, 51400 B, 51400 C, 51400 D, 51400 E, 51400 F, 51400 H, 51400 J, 51400 K, 51400 M, 51400 N, 51400 AC, 51600 A, 51700 C, 51700 D, 51700 E, 51700 F, 51700 G, 51700 H, 51700 T (screw No. 87 A) - - - - -	56
52894 J	Oil Tube Brace, for Styles 51200 A, 51200 B, 51200 C, 51200 D, 51200 G, 51200 H, 51200 J, 51200 U, 51200 V, 51400 A, 51400 B, 51400 C, 51400 D, 51400 E, 51400 F, 51400 G, 51400 H, 51400 J, 51400 K, 51400 M, 51400 N, 51400 AC, 51600 A (screw No. 22585, nut No. 41071 G) -	47
52894 Y	Oil Line "T" Coupling, for inner right main shaft bearing on Styles 51200 A, 51200 B, 51200 C, 51200 D, 51200 G, 51200 H, 51200 J, 51200 U, 51200 V, 51400 A, 51400 B, 51400 C, 51400 D, 51400 E, 51400 F, 51400 G, 51400 H, 51400 J, 51400 K, 51400 M, 51400 N, 51400 AC, 51600 A, 51700 C, 51700 D, 51700 E, 51700 G, 51700 H, 51700 T - - - - -	46
52894 Z	Oil Tube, leading from oil gauge to inner right main shaft bearing "T" coupling on Styles 51200 A, 51200 B, 51200 C, 51200 D, 51200 G, 51200 H, 51200 J, 51200 U, 51200 V, 51400 A, 51400 B, 51400 C, 51400 D, 51400 E, 51400 F, 51400 G, 51400 H, 51400 J, 51400 K, 51400 M, 51400 N, 51400 AC, 51600 A, 51700 C, 51700 D, 51700 E, 51700 F, 51700 G, 51700 H, 51700 T (coupling No. 61294 X) - - - - -	19
52895 G	Main Shaft Oil Gauge Frame for Styles 51200 A, 51200 B, 51200 C, 51200 D, 51200 G, 51200 H, 51200 J, 51200 U, 51200 V, 51400 A, 51400 B, 51400 C, 51400 D, 51400 E, 51400 F, 51400 G, 51400 H, 51400 J, 51400 K, 51400 M, 51400 N, 51400 AC, 51600 A, 51700 C, 51700 D, 51700 E, 51700 F, 51700 G, 51700 H, 51700 T - - - - -	47
52944 G	Looper Rock Shaft Sleeve, for Style 51400 G (screw No. 88 B) - - - - -	41
52958	Looper Thread Cast-off Support Thread Eyelet, for Styles 51400 Q, 51400 R, 51400 S, 51400 U, 51400 Y, 51400 AA, 51400 AB, 51700 J, 51700 K, No. 64 gauge Style 51700 L, Styles 51700 Q, 51700 R (screw No. 22768) - - - - -	18

## LIST OF PARTS

Symbol to Order By	The figures in the last column refer only to the plates illustrating the parts and are not to be used in ordering. Prices furnished on application.	Plate No.
K53133	Folder, upper, for attaching cuffs, to pajamas on Styles 51700 H, 51700 P, using strip 2 5/8 inches wide, 3/64 inch capacity (screw No. 94) - - - - -	55
K53135	Folder, upper, for attaching cuffs to pajamas on Styles 51700 G, 51700 N, using strip 2 5/8 inches wide, 1/32 inch capacity (screw No. 94) - - - - -	55
53556 C	Presser Bar Bushing, lower, for Styles 51200 U, 51200 V, 51400 G, 51400 AC, 51600 A, 51700 T	27
K53581	Folder, 3/64 inch capacity, for attaching one piece extension button stays on Styles 51200 V, 5/8 inch finish, strip cut 1 3/4 inch wide; similar in design to No. K 53941 (folder clamp screw No. 22597 A) - - - - -	-
53582 H	Face Plate, for Styles 51200 U, 51200 V (thumbscrew No. 22837) - - - - -	48
53582 N	Crank Shaft Chamber Cover, upper, rear, includes oil catch plate No. 52782 H for Styles 51200 U, 51200 V, 51400 G, 51400 AC, 51600 A, 51700 T (screw No. 22872) - - - - -	46
53592	Tension Post Support, for styles in Class 51700, Styles 51400 A, 51400 B, 51400 C, 51400 D, 51400 E, 51400 F, 51400 H, 51400 J, 51400 K, 51400 M, 51400 N, 51400 P, 51400 Q, 51400 R, 51400 S, 51400 T, 51400 U, 51400 V, 51400 W, 51400 X, 51400 Y, 51400 AA, 51400 AB - - - - -	38
K53842	Presser Foot, for No. 32 gauge Style 51700 L (Yielding section spring No. 16194, yielding section spring attaching screw No. 605, yielding section spring adjusting screw No. 605 A, yielding section spring clamp screw No. 605, presser bar set screw No. 88) - - -	12
K53843	Throat Plate, for No. 32 gauge Style 51700 L (screw No. 22570) - - - - -	6
K53844	Feed Dog, for No. 32 gauge Style 51700 L (screw No. 22528) - - - - -	9
K53845	Differential Feed Roll, upper, for No. 32 gauge Style 51700 L (set screw No. 22743) - - - - -	15
K53846	Differential Feed Roll Shaft, for Nos. 32 and 40 gauge Style 51700 L - - - - -	15
K53847	Differential Feed Roll Yoke, for Nos. 32 and 40 gauge Style 51700 L (screw No. 88) - - - - -	38
K53848	Differential Feed Roll, lower for Nos. 32 and 40 gauge Style 51700 L (screw No. 22565 C) -	15
K53849	Lower Roll Bracket, for Nos. 32 and 40 gauge Style 51700 L (attaching screw No. 87) - - -	38
K53850	Lower Roll Shaft and Driving Pinion, for Nos. 32 and 40 gauge Styles 51700 L - - - - -	15

LIST OF PARTS

Symbol to Order By	The figures in the last column refer only to the plates illustrating the parts and are not to be used in ordering. Prices furnished on application.	Plate No.
K53851	Stripper Blade, for No. 32 gauge Style 51700 L (screw No. 22726 A) - - - - -	37
K53852	Body Folder, complete, 1/16 inch capacity, for Nos. 32 and 40 gauge Style 51700 L (sliding base No. 23449 A, sliding base guide No. 23449 B, spring No. 23449 C, spring attach- ing screw No. 187 A, pivot stud No. 22735, pivot stud spring washer No. 12957 E, stripper blade adjusting stud No. 22532, stripper blade set screw No. 88, body folder attaching screw No. 25 C) - - - - -	34
K53853	Strip Folder, for No. 32 gauge Style 51700 L -	36
K53854	Guide, for leading strip to feed dog on No. 32 gauge Style 51700 L (guide screw No. 22504, guide spring, No. 51785, guide washer No. 8372 A) - - - - -	38
K53855	Differential Feed Roll Yoke Support Bracket, for Nos. 32 and 40 gauge Style 51700 L (attaching screw No. 93) - - - - -	37
K53889	Needle Bar, for No. 12 gauge Style 51600 A - -	44
K53890	Looper, front, for No. 12 gauge Style 51600 A (set screw No. 73) - - - - -	15
K53891	Looper, back, for Nos. 8, 10, and 12 gauge Style 51600 A (set screw No. 73) - - - - -	16
K53941	Folder, 3/64 inch capacity for attaching one piece extension button stays on Style 51200 V, 3/8 inch finish, strip cut 1/8 inches wide (folder clamp screw No. 22597) -	36
K54258	Presser Foot, for No. 40 gauge Style 51700 L (yielding section spring No. 16194, yielding section spring screw No. 605, yielding sec- tion spring adjusting screw No. 605 A, yielding section spring clamp screw No. 605, set screw No. 88) - - - - -	13
K54259	Throat Plate, for No. 40 gauge Style 51700 L (screw No. 22570) - - - - -	6
K54260	Feed Dog, for No. 40 gauge Style 51700 L (screw No. 22528) - - - - -	9
K54261	Differential Feed Roll, upper for No. 40 gauge Style 51700 L (set screw No. 22743) - - - - -	15
K54262	Stripper Blade, for No. 40 gauge Style 51700 L (screw No. 22726 A) - - - - -	37
K54264	Guide, for leading strip to feed dog on No. 40 gauge Style 51700 L (guide screw No. 22504, guide spring No. 51785, guide washer No. 8372 A) - - - - -	38
K54654	Cloth Plate Cover, 7 13/32 inches long, for Style 51200 H - - - - -	56
K55001	Looper, front, for No. 18 gauge Styles 51400 H, 51400 V (set screw No. 73) - - - - -	15



## LIST OF PARTS

Symbol to Order By	The figures in the last column refer only to the plates illustrating the parts and are not to be used in ordering. Prices furnished on application.	Plate No.
55241 N	Looper Connecting Rod Ball Joint Assembly, left, for Styles in Classes 51200, 51400, Nos. 32 and 40 gauge Style 51700 L, equipped with looper drive levers Nos. 51242 N, 51242 U (bearing screw No. 97 A, nut No.18 ) -	29
K55310	Folder Swinging Arm Block, 1/4 inch thick for Styles 51700 G, 51700 H, 51700 N, 51700 P (screw No. 22874) - - - - -	37
K55601	Cloth Plate, for Styles 51700 G, 51700 H (screw No. 80) - - - - -	60
K55603	Cloth Plate, for Style 51700 F (screw No. 80) -	60
*55641	Looper Connecting Rod Ball Joint left, for Styles 51700 C, 51700 D, 51700 E, 51700 F, 51700 G, 51700 H, 51700 J, 51700 K, Nos. 64, 72 and 80 gauge Style 51700 L, Styles 51700 M, 51700 N, 51700 P, 51700 Q, 51700 R, 51700 T, 51700 U equipped with looper drive levers No. 51242 N, 51242 U (bearing screw No. 97 A) - - - - -	29
K55764	Presser Foot, for Styles 51700 T, 51700 U (set screw No. 22570, yielding section spring No. 16194, yielding section spring attaching screw No. 605, yielding section spring adjusting screw No. 605 A, yielding section spring support screw No. 87 U, right section tilting spring No. 16241, right section tilting spring screw No. 604, left section tilting spring No. 16241 A, left section tilting spring screw No. 605) - - - - -	12
K55765	Cloth Plate, for Style 51700 T (screw No. 80) -	60
K56034	Strip Folder, for No. 40 gauge Style 51700 L -	36
K56823	Looper, front, for No. 10 gauge Style 51600 A (set screw No. 73) - - - - -	15
K56824	Needle Bar, for No. 10 gauge Style 51600 A - -	44
K57253	Upper Feed Roll, for Style 51200 U - - - - -	15
K57257	Roller Feed Clutch Driving Lever, for Styles 51200 U, 51200 V - - - - -	43
K57269	Feed Dog, for Style 51200 V (screw No. 22593) -	6
K57270	Upper Feed Roll, for Style 51200 V - - - - -	15
K57272	Attachment Locking Lever, for Style 51200 V (nut No. 12982) - - - - -	30
K57279	Presser Foot and top Roller Feed Assembly, for Style 51200 U; one each Nos. K57282, 90, 15872 D, 22799 P, 22834, K57253, K57283; two No. 22830 - - - - -	10
K57282	Presser Foot Bottom. for Style 51200 U (hinge screw No. 22799 P, screw for toe guide No. 605) - - - - -	13
K57283	Presser Foot Shank, for Style 51200 U (clamp screw No. 22830, feed roller support adjusting screw No. 22834) - - - - -	14

LIST OF PARTS

Symbol to Order By	The figures in the last column refer only to the plates illustrating the parts and are not to be used in ordering. Prices furnished on application.	Plate No.
K57284	Feed Roller Support, for Styles 51200 U, 51200 V (pivot stud No. 15872 D, locking screw No.90)-	14
K57341	Presser Foot Yielding Section Spring, for Style 51200 V (screw No. 57 WD)- - - - -	32
K57342	Presser Foot Yielding Section, for Style 51200 V (hinge screw No. 223 C)- - - - -	14
K57666	Needle Bar, for No. 16 gauge, Style 51600 A- - -	44
K57667	Looper, front, for No. 16 gauge Style 51600 A- -	15
K57668	Looper, back, for No. 16 gauge Style 51600 A - -	16
K57818	Looper, front, for No. 8 gauge Style 51600 A - -	15
	Looper Set Screw No. 73	
K57819	Needle Bar, for No. 16 gauge Style 51600 A - - -	44
K58001	Folder, 3/64 inch capacity for attaching one piece extension button stays on Style 51200 V, 3/4 inch finish, strip cut 2 inch wide (folder clamp screw No. 22597 A) - - - - -	36
K58111	Edge Guide, for Style 51200 V (screw No. 22561)-	33
K58131	Folder, 3/64 inch strip capacity for attaching one piece extension button stays on Style 51200 V, 9/16 inch finish, strip cut 1 5/8 inches wide; similar in design to No. K 58001 (folder clamp screw No. 22597 A) - - - - -	-
K58146	Folder, 3/64 inch capacity for attaching one piece extension button stays on Style 51200 V, 7/8 inch finish, strip cut 2 1/8 inches wide; similar in design to No. K58001 (folder clamp screw No. 22597 A) - - - - -	--
K58357	Center Plate Folder, 1/16 inch capacity for No. 64 gauge Style 51700 Q, 1 1/2 inch finish, strip cut 2 1/2 inches wide (folder clamp screw No. 25 S)- - - - -	55
K58494	Needle Rear Guard, for Style 51600 A (screw No. 22874) - - - - -	16
K58495	Needle Guard Holder, for Styles 51400 AC, 51600 A (screw No. 22874)- - - - -	17
K59002	Needle Rear Guard, for Style 51400 AC (screw No. 22874) - - - - -	16
K59080	Presser Foot Shank, for Style 51200 V (clamp screw No. 22830, feed roller support adjusting screw No. 22834) - - - - -	14
K59088	Presser Foot and Top Roller Feed Assembly, with left yielding section, for Style 51200 V; one each Nos. K59080, 57 WD, 90, 223 C, 15872 D, 22834, K57270, K57284, K57341, K57342; two No. 22830- - - - -	10
K59286	Folder, 3/64 inch strip capacity, for attaching one piece extension button stays on Style 51200 V, 1 inch finish, strip cut 2 3/8 inches wide; similar in design to K58001 (folder clamp screw No. 22597 A) - - - - -	-

LIST OF PARTS

Symbol to Order By	The figures in the last column refer only to the plates illustrating the parts and are not to be used in ordering. Prices furnished on application.	Plate No.
K59386	Folder, for turning body of garment downwardly on Style 51700 R, 1/16 inch capacity, 5/16 inch fold (screw No. 25 C) - - - - -	33
K59432	Folder, for turning body of garment upwardly, on Style 51700 Q, 1/16 inch capacity, 5/16 inch fold (screw No. 25 C) - - - - -	35
K59465	Cloth Plate, for Styles 51200 K, 51200 L, 51200 N (screw No. 80) - - - - -	60
K59466	Cloth Plate, for Style 51700 M (screw No. 80) - -	61
K59488	Cloth Plate Cover Spring, for Styles 51200 K, 51200 L, 51200 N, Nos. 64, 72, and 80 gauge Style 51700 L, Style 51700 M (screw No. 22726 A) - - - - -	49
K59498	Main Feed Dog, for Style 51400 AC (screw No. 22593) - - - - -	7
K59499	Differential Feed Dog, for Style 51400 AC (screw No. 90) - - - - -	6
K59500	Throat Plate, for No. 12 gauge Style 51400 AC (screw No. 22570) - - - - -	4
K59502	Throat Plate, for No. 16 gauge Style 51400 AC (screw No. 22570) - - - - -	4
K59503	Lap Seam Feller, complete, 1/16 inch capacity, for Nos. 12 and 16 gauge Style 51400 AC (upper scroll screw No. 22513, attaching screw No. 25 C) - - - - -	34
K59510	Cloth Plate, for Style 51700 U (screw 33/64 inch long, No. 80, screw 21/32 inch long, No. 22574) - - - - -	61
K59581	Cloth Plate, for Nos. 64, 72, and 80 gauge Style 51700 L (screw No. 80) - - - - -	61
K59594	Tube, left, for oil line to main shaft bearings on Style 51400 G - - - - -	47
K59612	Folder, 3/64 inch capacity, for attaching one piece extension button stays on Style 51200 V, 1/2 inch finish, strip cut 1 3/8 inch wide; similar in design to No. K58001 (folder clamp screw No. 22597 A) - - - - -	-
K59825	Facing Strip Folder, 1/16 inch capacity, uses 1 3/8 inch strip, finishes 1 inch, for Style 51700 R (washer No. 9255, screw No. 22548) - -	54
K59843	Throat Plate, for Style 51700 R (screw No. 22570) - - - - -	5
K59882	Folder, 1/32 inch capacity, for 1/2 inch button stay on Style 51200 U, uses 1 1/2 inch strip (screw No. 25 C, washer plate No. 23425 V) - -	54
K59922	Cloth Plate, for Nos. 32 and 40 gauge Style 51700 L (screw No. 80) - - - - -	60
K59923	Cloth Plate Cover, for Nos. 32 and 40 gauge Style 51700 L - - - - -	48
K60059	Throat Plate Support, for Style 51600 A (screw No. 80) - - - - -	55

LIST OF PARTS

Symbol to Order By	The figures in the last column refer only to the plates illustrating the parts and are not to be used in ordering. Prices furnished on application.	Plate No.
K60092	Feed Dog, for Style 51200 U (screw No. 22528) - - - - -	7
K60093	Throat Plate, for Style 51200 U (screw No. 87) - - - - -	1
K60150	Throat Plate, for Style 51200 V (screw No. 87) - - - - -	1
K60151	Main Feed Dog, for Style 51200 V (screw No. 22593) - - - - -	7
K60416	Stripper Blade, for No. 12 gauge Style 51400 AC (screw No. 187 A) - - - - -	37
K60417	Presser Foot, for No. 12 gauge Style 51400 AC (clamp screw No. 22765, hinge screw No. 22799 E) - - - - -	11
K60418	Stripper Blade, for No. 16 gauge Style 51400 AC (screw No. 187 A) - - - - -	37
K60419	Presser Foot, for No. 16 gauge Style 51400 AC (clamp screw No. 22765, hinge screw No. 22799 E) - - - - -	11
61267 G	Lifter Lever Spring Pin, for Styles 51200 U, 51200 V, 51400 G, 51400 AC, 51600 A, 51700 T; also differential feed control lever spring pin on Styles 51200 V, 51400 AC, 51600 A, - - - - -	29
61294 W	Oil Tube Coupling, for oil gauge tube; also for middle mainshaft bearing oil tube on Styles 51200 A, 51200 B, 51200 C, 51200 D, 51200 G, 51200 H, 51200 J, 51200 U, 51200 V, 51400 A, 51400 B, 51400 C, 51400 D, 51400 E, 51400 F, 51400 H, 51400 J, 51400 K, 51400 M, 51400 N, 51400 AC, 51600 A, 51700 C, 51700 D, 51700 E, 51700 F, 51700 G, 51700 H, 51700 T - - - - -	19
61294 X	Coupling, for oil line tubes - - - - -	25
92201	Regulating Screw, for presser roller hand lifter lever on Style 51400 G (nut No. 12982) - - - - -	20

